



TAVİLLER
HİDROLİK BORU VE MİL İMALAT SANAYİ A.Ş.



TVL

güce
yön veren
teknoloji

TECNOLOGY TO
POWER DIRECTION

www.taviller.com.tr



www.taviller.com.tr





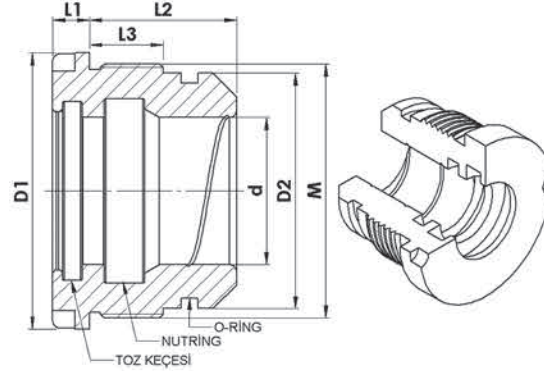

S.N	ÜRÜN KODU	D1	D2	d	M	L3	L2	L1	KEÇE KODU	TOZ KEÇESİ	NUTRING	O-RİNG
1	TDK032 016	42	33	16	M.36x1,5	17	32	8	KTDK032 016	16x24x7/5	16x22x5	28x3
2	TDK032 018	42	33	18	M.36x1,5	17	32	8	KTDK032 018	18x26x7/5	18x25x5	28x3
3	TDK032 020	42	33	20	M.36x1,5	17	32	8	KTDK032 020	20x28x7/5	20x30x6	28x3
4	TDK032 022	42	33	22	M.36x1,5	17	32	8	KTDK032 022	22x30x7/5	22x32x6	28x3
5	TDK035 020	45	36	20	M.39x1,5	17	32	8	KTDK035 020	20x28x7/5	20x30x6	30x3
6	TDK035 022	45	36	22	M.39x1,5	17	32	8	KTDK035 022	22x30x7/5	22x32x6	30x3
7	TDK035 025	45	36	25	M.39x1,5	17	32	8	KTDK035 025	25x33x7/5	25x35x6	30x3
8	TDK040 018	50	41	18	M.44x1,5	17	32	8	KTDK040 018	18x26x7/5	18x25x5	36x3
9	TDK040 020	50	41	20	M.44x1,5	17	32	8	KTDK040 020	20x28x7/5	20x30x6	36x3
10	TDK040 022	50	41	22	M.44x1,5	17	32	8	KTDK040 022	22x30x7/5	22x32x6	36x3
11	TDK040 025	50	41	25	M.44x1,5	17	32	8	KTDK040 025	25x33x7/5	25x35x6	36x3
12	TDK040 028	50	41	28	M.44x1,5	17	32	8	KTDK040 028	28x36x7/5	28x38x7	36x3
13	TDK045 020	55	46	20	M.49x1,5	17	32	8	KTDK045 020	20x28x7/5	20x30x6	40x3
14	TDK045 025	55	46	25	M.49x1,5	17	32	8	KTDK045 025	25x33x7/5	25x35x6	40x3
15	TDK045 028	55	46	28	M.49x1,5	17	32	8	KTDK045 028	28x36x7/5	28x38x7	40x3
16	TDK045 030	55	46	30	M.49x1,5	17	32	8	KTDK045 030	30x38x7/5	30x40x8	40x3
17	TDK050 020	60	51	20	M.54x1,5	19	35	8	KTDK050 020	20x28x7/5	20x30x6	45x3
18	TDK050 022	60	51	22	M.54x1,5	19	35	8	KTDK050 022	22x30x7/5	22x32x6	45x3
19	TDK050 025	60	51	25	M.54x1,5	19	35	8	KTDK050 025	25x33x7/5	25x35x6	45x3
20	TDK050 028	60	51	28	M.54x1,5	19	35	8	KTDK050 028	28x36x7/5	28x38x7	45x3
21	TDK050 030	60	51	30	M.54x1,5	19	35	8	KTDK050 030	30x38x7/5	30x40x8	45x3
22	TDK050 032	60	51	32	M.54x1,5	19	35	8	KTDK050 032	32x40x7/5	32x40x8	45x3
23	TDK050 035	60	51	35	M.54x1,5	19	35	8	KTDK050 035	35x43x7/5	35x45x8	45x3
24	TDK050 036	60	51	36	M.54x1,5	19	35	8	KTDK050 036	36x44x7/5	36x46x8	45x3
25	TDK055 025	65	56	25	M.59x1,5	19	35	8	KTDK055 025	25x33x7/5	25x35x6	49,21x3,53
26	TDK055 030	65	56	30	M.59x1,5	19	35	8	KTDK055 030	30x38x7/5	30x40x8	49,21x3,53
27	TDK055 035	65	56	35	M.59x1,5	19	35	8	KTDK055 035	35x43x7/5	35x45x8	49,21x3,53
28	TDK060 025	70	61	25	M.64x1,5	20	40	10	KTDK060 025	25x33x7/5	25x35x6	53,57x3,53
29	TDK060 030	70	61	30	M.64x1,5	20	40	10	KTDK060 030	30x38x7/5	30x40x8	53,57x3,53
30	TDK060 035	70	61	35	M.64x1,5	20	40	10	KTDK060 035	35x43x7/5	35x45x8	53,57x3,53
31	TDK060 040	70	61	40	M.64x1,5	20	40	10	KTDK060 040	40x48x7/5	40x50x10	53,57x3,53
32	TDK060 045	70	61	45	M.64x1,5	20	40	10	KTDK060 045	45x55x7/5	45x55x10	53,57x3,53

TÜM İMALATLARIMIZ KASTAŞ KEÇE TOLERANSLARINA UYGUNDUR.

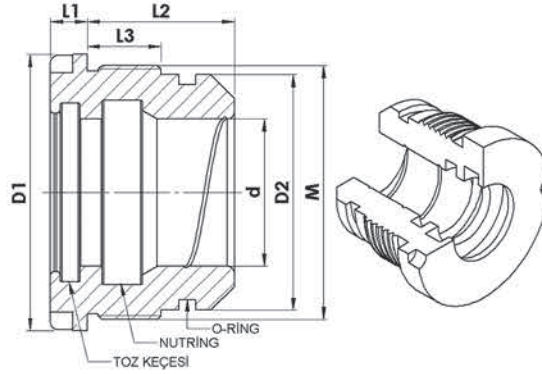

S.N	ÜRÜN KODU	D1	D2	d	M	L3	L2	L1	KEÇE KODU	TOZ KEÇESİ	NUTRING	O-RİNG
33	TDK063 030	75	64	30	M.69x1,5	20	40	10	KTDK063 030	30x38x7/5	30x40x8	57,15x3,53
34	TDK063 035	75	64	35	M.69x1,5	20	40	10	KTDK063 035	35x43x7/5	35x45x8	57,15x3,53
35	TDK063 036	75	64	36	M.69x1,5	20	40	10	KTDK063 036	36x44x7/5	36x46x8	57,15x3,53
36	TDK063 040	75	64	40	M.69x1,5	20	40	10	KTDK063 040	40x48x7/5	40x50x10	57,15x3,53
37	TDK063 045	75	64	45	M.69x1,5	20	40	10	KTDK063 045	45x55/7/5	45x55x10	57,15x3,53
38	TDK065 030	80	66	30	M.70x1,5	29	50	10	KTDK065 030	30x38x7/5	30x40x8	59,92x3,53
39	TDK065 035	80	66	35	M.70x1,5	29	50	10	KTDK065 035	35x43x7/5	35x45x8	59,92x3,53
40	TDK065 040	80	66	40	M.70x1,5	29	50	10	KTDK065 040	40x48x7/5	40x50x10	59,92x3,53
41	TDK065 045	80	66	45	M.70x1,5	29	50	10	KTDK065 045	45x55x7/5	45x55x10	59,92x3,53
42	TDK070 025	85	71	25	M.74x1,5	29	50	10	KTDK070 025	25x33x7/5	25x35x6	65,10x3,53
43	TDK070 030	85	71	30	M.74x1,5	29	50	10	KTDK070 030	30x38x7/5	30x40x8	65,10x3,53
44	TDK070 035	85	71	35	M.74x1,5	29	50	10	KTDK070 035	35x43x7/5	35x45x8	65,10x3,53
45	TDK070 036	85	71	36	M.74x1,5	29	50	10	KTDK070 036	36x44x7/5	36x46x8	65,10x3,53
46	TDK070 040	85	71	40	M.74x1,5	29	50	10	KTDK070 040	40x48x7/5	40x50x10	65,10x3,53
47	TDK070 045	85	71	45	M.74x1,5	29	50	10	KTDK070 045	45x55x7/5	45x55x10	65,10x3,53
48	TDK070 050	85	71	50	M.74x1,5	29	50	10	KTDK070 050	50x60x7/5	50x60x10	65,10x3,53
49	TDK070 055	85	71	55	M.74x1,5	29	50	10	KTDK070 055	55x65x7/5	55x65x10	65,10x3,53
50	TDK075 030	90	76	30	M.80x1,5	29	50	10	KTDK075 030	30x38x7/5	30x40x8	69,45x3,53
51	TDK075 035	90	76	35	M.80x1,5	29	50	10	KTDK075 035	35x43x7/5	35x45x8	69,45x3,53
52	TDK075 040	90	76	40	M.80x1,5	29	50	10	KTDK075 040	40x48x7/5	40x50x10	69,45x3,53
53	TDK075 045	90	76	45	M.80x1,5	29	50	10	KTDK075 045	45x55x7/5	45x55x10	69,45x3,53
54	TDK075 050	90	76	50	M.80x1,5	29	50	10	KTDK075 050	50x60x7/5	50x60x10	69,45x3,53
55	TDK075 055	90	76	55	M.80x1,5	29	50	10	KTDK075 055	55x65x7/5	55x65x10	69,45x3,53
56	TDK080 030	95	81	30	M.85x2	29	50	10	KTDK080 030	30x38x7/5	30x40x8	74,61x3,53
57	TDK080 035	95	81	35	M.85x2	29	50	10	KTDK080 035	35x43x7/5	35x45x8	74,61x3,53
58	TDK080 040	95	81	40	M.85x2	29	50	10	KTDK080 040	40x48x7/5	40x50x10	74,61x3,53
59	TDK080 045	95	81	45	M.85x2	29	50	10	KTDK080 045	45x55x7/5	45x55x10	74,61x3,53
60	TDK080 050	95	81	50	M.85x2	29	50	10	KTDK080 050	50x60x7/5	50x60x10	74,61x3,53
61	TDK080 055	95	81	55	M.85x2	29	50	10	KTDK080 055	55x65x7/5	55x65x10	74,61x3,53
62	TDK080 056	95	81	56	M.85x2	29	50	10	KTDK080 056	56x66x5/7	56x66x8	74,61x3,53
63	TDK080 060	95	81	60	M.85x2	29	50	10	KTDK080 060	60x70x7/5	60x70x10	74,61x3,53

TÜM İMALATLARIMIZ KASTAŞ KEÇE TOLERANSLARINA UYGUNDUR.

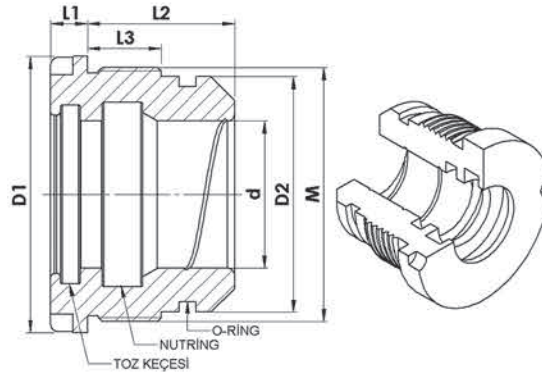

S.N	ÜRÜN KODU	D1	D2	d	M	L3	L2	L1	KEÇE KODU	TOZ KEÇESİ	NUTRİNG	O-RİNG
64	TDK085 035	100	86	35	M.90x2	29	50	10	KTDK085 035	35x43x7/5	35x45x8	78x4
65	TDK085 040	100	86	40	M.90x2	29	50	10	KTDK085 040	40x48x7/5	40x50x10	78x4
66	TDK085 045	100	86	45	M.90x2	29	50	10	KTDK085 045	45x55x7/5	45x55x10	78x4
67	TDK085 050	100	86	50	M.90x2	29	50	10	KTDK085 050	50x60x7/5	50x60x10	78x4
68	TDK085 055	100	86	55	M.90x2	29	50	10	KTDK085 055	55x65x7/5	55x65x10	78x4
69	TDK085 060	100	86	60	M.90x2	29	50	10	KTDK085 060	60x70x7/5	60x70x10	78x4
70	TDK090 035	105	91	35	M.95x2	29	50	10	KTDK090 035	35x43x7/5	35x45x8	84x4
71	TDK090 040	105	91	40	M.95x2	29	50	10	KTDK090 040	40x48x7/5	40x50x10	84x4
72	TDK090 045	105	91	45	M.95x2	29	50	10	KTDK090 045	45x55x7/5	45x55x10	84x4
73	TDK090 050	105	91	50	M.95x2	29	50	10	KTDK090 050	50x60x7/5	50x60x10	84x4
74	TDK090 055	105	91	55	M.95x2	29	50	10	KTDK090 055	55x65x7/5	55x65x10	84x4
75	TDK090 060	105	91	60	M.95x2	29	50	10	KTDK090 060	60x70x7/5	60x70x10	84x4
76	TDK090 065	105	91	65	M.95x2	29	50	10	KTDK090 065	65x75x7/5	65x75x10	84x4
77	TDK090 070	105	91	70	M.95x2	29	50	10	KTDK090 070	70x80x7/5	70x80x12	84x4
78	TDK100 040	115	101	40	M.105x2	39	70	12	KTDK100 040	40x48x7/5	40x50x10	90x5
79	TDK100 045	115	101	45	M.105x2	39	70	12	KTDK100 045	45x55x7/5	45x55x10	90x5
80	TDK100 050	115	101	50	M.105x2	39	70	12	KTDK100 050	50x60x7/5	50x60x10	90x5
81	TDK100 055	115	101	55	M.105x2	39	70	12	KTDK100 055	55x65x7/5	55x65x10	90x5
82	TDK100 056	115	101	56	M.105x2	39	70	12	KTDK100 056	56x66x7/5	56x66x8	90x5
83	TDK100 060	115	101	60	M.105x2	39	70	12	KTDK100 060	60x70x7/5	60x70x10	90x5
84	TDK100 065	115	101	65	M.105x2	39	70	12	KTDK100 065	65x75x7/5	65x75x10	90x5
85	TDK100 070	115	101	70	M.105x2	39	70	12	KTDK100 070	70x80x7/5	70x80x12	90x5
86	TDK100 075	115	101	75	M.105x2	39	70	12	KTDK100 075	75x87x12/7	75x85x12	90x5
87	TDK100 080	115	101	80	M.105x2	39	70	12	KTDK100 080	80x92x12/7	80x90x12	90x5
94	TDK110 050	130	111	50	M.115x2	39	70	12	KTDK110 050	50x60x7/5	50x60x10	100x5
95	TDK110 055	130	111	55	M.115x2	39	70	12	KTDK110 055	55x65x7/5	55x65x10	100x5
96	TDK110 056	130	111	56	M.115x2	39	70	12	KTDK110 056	56x66x7/5	56x66x8	100x5
97	TDK110 060	130	111	60	M.115x2	39	70	12	KTDK110 060	60x70x7/5	60x70x10	100x5
98	TDK110 065	130	111	65	M.115x2	39	70	12	KTDK110 065	65x75x7/5	65x75x10	100x5
99	TDK110 070	130	111	70	M.115x2	39	70	12	KTDK110 070	70x80x7/5	70x80x12	100x5
100	TDK110 075	130	111	75	M.115x2	39	70	12	KTDK110 075	75x87x12/7	75x85x12	100x5
101	TDK110 080	130	111	80	M.115x2	39	70	12	KTDK110 080	80x92x12/7	80x90x12	100x5

TÜM İMALATLARIMIZ KASTAŞ KEÇE TOLERANSLARINA UYGUNDUR.

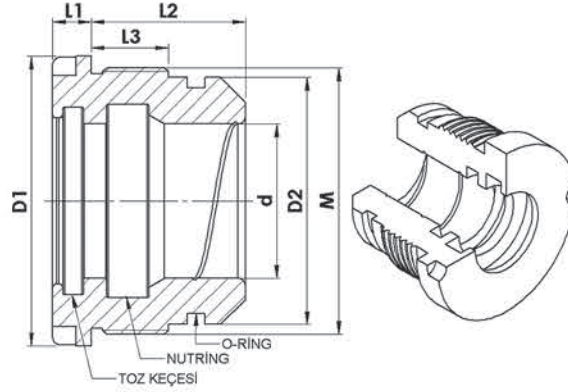

S.N	ÜRÜN KODU	D1	D2	d	M	L3	L2	L1	KEÇE KODU	TOZ KEÇESİ	NUTRİNG	O-RİNG
102	TDK115 050	135	116	50	M.120X2	39	70	12	KTDK115 050	50x60x7/5	50x60x10	105x5
103	TDK115 055	135	116	55	M.120X2	39	70	12	KTDK115 055	55x65x7/5	55x65x10	105x5
104	TDK115 060	135	116	60	M.120X2	39	70	12	KTDK115 060	60x70x7/5	60x70x10	105x5
105	TDK115 065	135	116	65	M.120X2	39	70	12	KTDK115 065	65x75x7/5	65x75x10	105x5
106	TDK115 070	135	116	70	M.120X2	39	70	12	KTDK115 070	70x80x7/5	70x80x12	105x5
107	TDK115 075	135	116	75	M.120X2	39	70	12	KTDK115 075	75x87x12/7	75x85x12	105x5
108	TDK115 080	135	116	80	M.120X2	39	70	12	KTDK115 080	80x92x12/7	80x90x12	105x5
109	TDK115 090	135	116	90	M.120X2	39	70	12	KTDK115 090	90x102x12/7	90x100x12	105x5
110	TDK120 045	140	121	45	M.125x2	39	70	12	KTDK120 045	45x55x7/5	45x55x10	110x5
111	TDK120 050	140	121	50	M.125x2	39	70	12	KTDK120 050	50x60x7/5	50x60x10	110x5
112	TDK120 055	140	121	55	M.125x2	39	70	12	KTDK120 055	55x65x7/5	55x65x10	110x5
113	TDK120 060	140	121	60	M.125x2	39	70	12	KTDK120 060	60x70x7/5	60x70x10	110x5
114	TDK120 065	140	121	65	M.125x2	39	70	12	KTDK120 065	65x75x7/5	65x75x10	110x5
115	TDK120 070	140	121	70	M.125x2	39	70	12	KTDK120 070	70x80x7/5	70x80x12	110x5
116	TDK120 075	140	121	75	M.125x2	39	70	12	KTDK120 075	75x87x12/7	75x85x12	110x5
117	TDK120 080	140	121	80	M.125x2	39	70	12	KTDK120 080	80x92x12/7	80x90x12	110x5
118	TDK120 085	140	121	85	M.125x2	39	70	12	KTDK120 085	85x97x12/7	85x95x12	110x5
119	TDK120 090	140	121	90	M.125x2	39	70	12	KTDK120 090	90x102x12/7	90x100x12	110x5
120	TDK125 050	145	126	50	M.130x2	39	70	12	KTDK125 050	50x60x5/7	50x60x10	110x5
121	TDK125 055	145	126	55	M.130x2	39	70	12	KTDK125 055	55x65x5/7	55x65x10	110x5
122	TDK125 060	145	126	60	M.130x2	39	70	12	KTDK125 060	60x70x5/7	60x70x10	115x5
123	TDK125 065	145	126	65	M.130x2	39	70	12	KTDK125 065	65x75x5/7	65x75x10	115x5
124	TDK125 070	145	126	70	M.130x2	39	70	12	KTDK125 070	70x80x5/7	70x80x12	115x5
125	TDK125 075	145	126	75	M.130x2	39	70	12	KTDK125 075	75x87x7/12	75x85x12	115x5
126	TDK125 080	145	126	80	M.130x2	39	70	12	KTDK125 080	80x92x7/12	80x90x12	115x5
127	TDK125 085	145	126	85	M.130x2	39	70	12	KTDK125 085	85x97x7/12	85x95x12	115x5
128	TDK125 090	145	126	90	M.130x2	39	70	12	KTDK125 090	90x102x7/12	90x100x12	115x5

TÜM İMALATLARIMIZ KASTAŞ KEÇE TOLERANSLARINA UYGUNDUR.

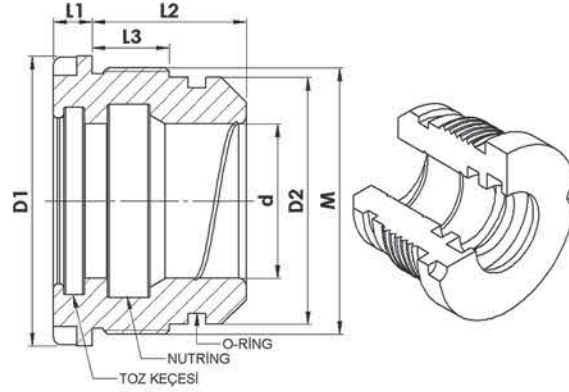

S.N	ÜRÜN KODU	D1	D2	d	M	L3	L2	L1	KEÇE KODU	TOZ KEÇESİ	NUTRİNG	O-RİNG
129	TDK130 060	150	131	60	M.135x2	58	90	12	KTDK130 060	60x70x7/5	60x70x10	119,30x5,70
130	TDK130 070	150	131	70	M.135x2	58	90	12	KTDK130 070	70x80x7/5	70x80x12	119,30x5,70
131	TDK130 075	150	131	75	M.135x2	58	90	12	KTDK130 075	75x87x12/7	75x85x12	119,30x5,70
132	TDK130 080	150	131	80	M.135x2	58	90	12	KTDK130 080	80x92x12/7	80x90x12	119,30x5,70
133	TDK130 085	150	131	85	M.135x2	58	90	12	KTDK130 085	85x97x12/7	85x95x12	119,30x5,70
134	TDK130 090	150	131	90	M.135x2	58	90	12	KTDK130 090	90x102x12/7	90x100x12	119,30x5,70
135	TDK130 100	150	131	100	M.135x2	58	90	12	KTDK130 100	100x112x12/7	100x120x12	119,30x5,70
136	TDK140 060	160	141	60	M.145x2	58	90	12	KTDK140 060	60x70x7/5	60x70x10	129,30x5,70
137	TDK140 065	160	141	65	M.145x2	58	90	12	KTDK140 065	65x75x7/5	65x75x10	129,30x5,70
138	TDK140 070	160	141	70	M.145x2	58	90	12	KTDK140 070	70x80x7/5	70x80x12	129,30x5,70
139	TDK140 075	160	141	75	M.145x2	58	90	12	KTDK140 075	75x87x12/7	75x85x12	129,30x5,70
140	TDK140 080	160	141	80	M.145x2	58	90	12	KTDK140 080	80x92x12/7	80x90x12	129,30x5,70
141	TDK140 085	160	141	85	M.145x2	58	90	12	KTDK140 085	85x97x12/7	85x95x12	129,30x5,70
142	TDK140 090	160	141	90	M.145x2	58	90	12	KTDK140 090	90x102x12/7	90x100x12	129,30x5,70
143	TDK140 100	160	141	100	M.145x2	58	90	12	KTDK140 100	100x112x12/7	100x120x12	129,30x5,70
144	TDK140 105	160	141	105	M.145x2	58	90	12	KTDK140 105	105x117x12/7	105x115x12	129,30x5,70
145	TDK140 110	160	141	110	M.145x2	58	90	12	KTDK140 110	110x122x12/7	110x125x12	129,30x5,70
146	TDK150 060	170	151	60	M.155x2	58	90	12	KTDK150 060	60x70x7/5	60x70x10	139,30x5,70
147	TDK150 070	170	151	70	M.155x2	58	90	12	KTDK150 070	70x80x7/5	70x80x12	139,30x5,70
148	TDK150 075	170	151	75	M.155x2	58	90	12	KTDK150 075	75x87x12/7	75x85x12	139,30x5,70
149	TDK150 080	170	151	80	M.155x2	58	90	12	KTDK150 080	80x92x12/7	80x90x12	139,30x5,70
150	TDK150 085	170	151	85	M.155x2	58	90	12	KTDK150 085	85x97x7/12	85x95x12	139,30x5,70
151	TDK150 090	170	151	90	M.155x2	58	90	12	KTDK150 090	90x102x7/12	90x100x12	139,30x5,70
152	TDK150 100	170	151	100	M.155x2	58	90	12	KTDK150 100	100x112x7/12	100x120x12	139,30x5,70
153	TDK150 110	170	151	110	M.155x2	58	90	12	KTDK150 110	110x122x7/12	110x125x12	139,30x5,70

TÜM İMALATLARIMIZ KASTAŞ KEÇE TOLERANSLARINA UYGUNDUR.

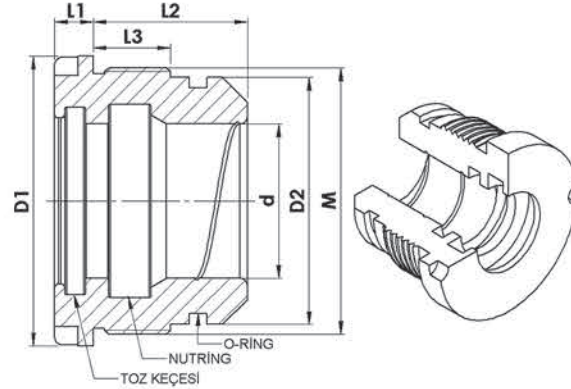

S.N	ÜRÜN KODU	D1	D2	d	M	L3	L2	L1	KEÇE KODU	TOZ KEÇESİ	NUTRİNG	O-RİNG
154	TDK160 060	180	161	60	M.165x2	58	90	12	KTDK160 060	60x70x7/5	60x70x10	149,20x5,70
155	TDK160 070	180	161	70	M.165x2	58	90	12	KTDK160 070	70x80x7/5	70x80x12	149,20x5,70
156	TDK160 080	180	161	80	M.165x2	58	90	12	KTDK160 080	80x92x12/7	80x90x12	149,20x5,70
157	TDK160 085	180	161	85	M.165x2	58	90	12	KTDK160 085	85x97x12/7	85x95x12	149,20x5,70
158	TDK160 090	180	161	90	M.165x2	58	90	12	KTDK160 090	90x102x12/7	90x100x12	149,20x5,70
159	TDK160 100	180	161	100	M.165x2	58	90	12	KTDK160 100	100x112x12/7	100x120x12	149,20x5,70
160	TDK160 110	180	161	110	M.165x2	58	90	12	KTDK160 110	110x122x12/7	110x125x12	149,20x5,70
161	TDK160 120	180	161	120	M.165x2	58	90	12	KTDK160 120	120x132x12/7	120x140x14,6	149,20x5,70
162	TDK170 080	200	171	80	M.176x2	58	90	14	KTDK170 080	80x92x12/7	80x90x12	159,20x5,70
163	TDK170 090	200	171	90	M.176x2	58	90	14	KTDK170 090	90x102x12/7	90x100x12	159,20x5,70
164	TDK170 100	200	171	100	M.176x2	58	90	14	KTDK170 100	100x112x12/7	100x120x12	159,20x5,70
165	TDK170 110	200	171	110	M.176x2	58	90	14	KTDK170 110	110x122x12/7	110x125x12	159,20x5,70
166	TDK170 120	200	171	120	M.176x2	58	90	14	KTDK170 120	120x132x12/7	120x140x14,6	159,20x5,70
167	TDK180 070	210	181	70	M.185x2	58	90	14	KTDK180 070	70x80x7/5	70x80x12	169,30x5,70
168	TDK180 080	210	181	80	M.185x2	58	90	14	KTDK180 080	80x92x12/7	80x90x12	169,30x5,70
169	TDK180 090	210	181	90	M.185x2	58	90	14	KTDK180 090	90x102x12/7	90x100x12	169,30x5,70
170	TDK180 100	210	181	100	M.185x2	58	90	14	KTDK180 100	100x112x12/7	100x120x12	169,30x5,70
171	TDK180 110	210	181	110	M.185x2	58	90	14	KTDK180 110	110x122x12/7	110x125x12	169,30x5,70
172	TDK180 120	210	181	120	M.185x2	58	90	14	KTDK180 120	120x132x12/7	120x140x14,6	169,30x5,70
173	TDK180 125	210	181	125	M.185x2	58	90	14	KTDK180 125	125x137x12/7	125x145x12	169,30x5,70
174	TDK180 130	210	181	130	M.185x2	58	90	14	KTDK180 130	130x142x12/7	130x150x15	169,30x5,70
175	TDK180 140	210	181	140	M.185x2	58	90	14	KTDK180 140	140x152x12/7	140x160x15	169,30x5,70
176	TDK200 090	245	201	90	M.205x2	58	90	14	KTDK200 090	90x102x12/7	90x100x12	189,30x5,70
177	TDK200 100	245	201	100	M.205x2	58	90	14	KTDK200 100	100x112x12/7	100x120x12	189,30x5,70
178	TDK200 110	245	201	110	M.205x2	58	90	14	KTDK200 110	110x122x12/7	110x125x12	189,30x5,70
179	TDK200 120	245	201	120	M.205x2	58	90	14	KTDK200 120	120x132x12/7	120x140x14,6	189,30x5,70
180	TDK200 130	245	201	130	M.205x2	58	90	14	KTDK200 130	130x142x12/7	130x150x15	189,30x5,70
181	TDK200 140	245	201	140	M.205x2	58	90	14	KTDK200 140	140x152x12/7	140x160x15	189,30x5,70
182	TDK220 100	270	221	100	M.226x2	58	90	14	KTDK220 100	100x112x12/7	100x120x12	209,20x5,70
183	TDK220 110	270	221	110	M.226x2	58	90	14	KTDK220 110	110x122x12/7	110x125x12	209,20x5,70
184	TDK220 120	270	221	120	M.226x2	58	90	14	KTDK220 120	120x132x12/7	120x140x14,6	209,20x5,70
185	TDK220 130	270	221	130	M.226x2	58	90	14	KTDK220 130	130x142x12/7	130x150x15	209,20x5,70
186	TDK220 140	270	221	140	M.226x2	58	90	14	KTDK220 140	140x152x12/7	140x160x15	209,20x5,70

TÜM İMALATLARIMIZ KASTAŞ KEÇE TOLERANSLARINA UYGUNDUR.

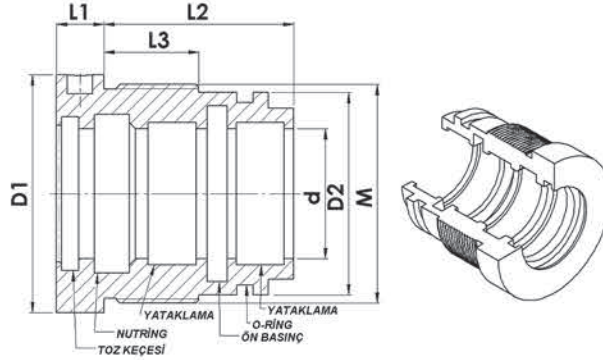

SN	ÜRÜN KODU	D1	D2	d	M.	L3	L2	L1	KEÇE KODU	TOZ KEÇESİ	NUTRİNG	YATAKLAMA	ÖN BASINÇ	O-RİNG
1	TCK040 020	50	41	20	M.45x2	20	45	10	KTCK040 020	20x28x7/5	20x30x6	20x24x9,4-(2)	YOK	36x3
2	TCK040 022	50	41	22	M.45x2	20	45	10	KTCK040 022	22x30x7/5	22x32x6	22x26x9,4-(2)	YOK	36x3
3	TCK040 025	50	41	25	M.45x2	20	45	10	KTCK040 025	25x33x7/5	25x35x6	25x29x9,4-(2)	YOK	36x3
4	TCK040 028	50	41	28	M.45x2	20	45	10	KTCK040 028	28x36x7/5	28x38x7	28x32x9,5-(2)	YOK	36x3
5	TCK050 025	60	51	25	M.55x2	20	45	10	KTCK050 025	25x33x7/5	25x35x6	25x29x9,4-(2)	YOK	45x3
6	TCK050 028	60	51	28	M.55x2	20	45	10	KTCK050 028	28x36x7/5	28x38x7	28x32x9,5-(2)	YOK	45x3
7	TCK050 030	60	51	30	M.55x2	20	45	10	KTCK050 030	30x38x7/5	30x40x8	30x34x9,5-(2)	YOK	45x3
8	TCK050 035	60	51	35	M.55x2	20	45	10	KTCK050 035	35x43x7/5	35x45x8	35x40x15-(2)	YOK	45x3
9	TCK055 025	65	56	25	M.60x2	20	45	10	KTCK055 025	25x33x7/5	25x35x6	25x29x9,4-(2)	YOK	49,21x3,53
10	TCK055 030	65	56	30	M.60x2	20	45	10	KTCK055 030	30x38x7/5	30x40x8	30x34x9,5-(2)	YOK	49,21x3,53
11	TCK055 035	65	56	35	M.60x2	20	45	10	KTCK055 035	35x43x7/5	35x45x8	35x40x15-(2)	YOK	49,21x3,53
12	TCK060 030	70	61	30	M.65x2	30	60	15	KTCK060 030	30x38x7/5	30x40x8	30x34x9,5-(2)	YOK	53,57x3,53
13	TCK060 035	70	61	35	M.65x2	30	60	15	KTCK060 035	35x43x7/5	35x45x8	35x40x15-(2)	YOK	53,57x3,53
14	TCK060 040	70	61	40	M.65x2	30	60	15	KTCK060 040	40x48x7/5	40x50x10	40x45x15-(2)	YOK	53,57x3,53
15	TCK060 045	70	61	45	M.65x2	30	60	15	KTCK060 045	45x55x7/5	45x55x10	45x50x15-(2)	YOK	53,57x3,53
16	TCK063 030	75	64	30	M.69x2	30	60	15	KTCK063 030	30x38x7/5	30x40x8	30x34x9,5-(2)	YOK	56x4
17	TCK063 035	75	64	35	M.69x2	30	60	15	KTCK063 035	35x43x7/5	35x45x8	35x40x15-(2)	YOK	56x4
18	TCK063 040	75	64	40	M.69x2	30	60	15	KTCK063 040	40x48x7/5	40x50x10	40x45x15-(2)	40x55x6	56x4
19	TCK063 045	75	64	45	M.69x2	30	60	15	KTCK063 045	45x55x7/5	45x55x10	45x50x15-(2)	YOK	56x4
20	TCK065 030	80	66	30	M.71x2	30	60	15	KTCK065 030	30x38x7/5	30x40x8	30x34x9,5-(2)	YOK	58x4
21	TCK065 035	80	66	35	M.71x2	30	60	15	KTCK065 035	35x43x7/5	35x45x8	35x40x15-(2)	YOK	58x4
22	TCK065 040	80	66	40	M.71x2	30	60	15	KTCK065 040	40x48x7/5	40x50x10	40x45x15-(2)	YOK	58x4
23	TCK065 045	80	66	45	M.71x2	30	60	15	KTCK065 045	45x55x7/5	45x55x10	45x50x15-(2)	YOK	58x4
24	TCK070 030	85	71	30	M.76x2	30	60	15	KTCK070 030	30x38x7/5	30x40x8	30x34x9,5-(2)	YOK	62x4
25	TCK070 035	85	71	35	M.76x2	30	60	15	KTCK070 035	35x43x7/5	35x45x8	35x40x15-(2)	YOK	62x4
26	TCK070 040	85	71	40	M.76x2	30	60	15	KTCK070 040	40x48x7/5	40x50x10	40x45x15-(2)	40x55x6	62x4
27	TCK070 045	85	71	45	M.76x2	30	60	15	KTCK070 045	45x55x7/5	45x55x10	45x50x15-(2)	45x60x6	62x4
28	TCK070 050	85	71	50	M.76x2	30	60	15	KTCK070 050	50x60x7/5	50x60x10	50x55x15-(2)	YOK	62x4

TÜM İMALATLARIMIZ KASTAŞ KEÇE TOLERANSLARINA UYGUNDUR.

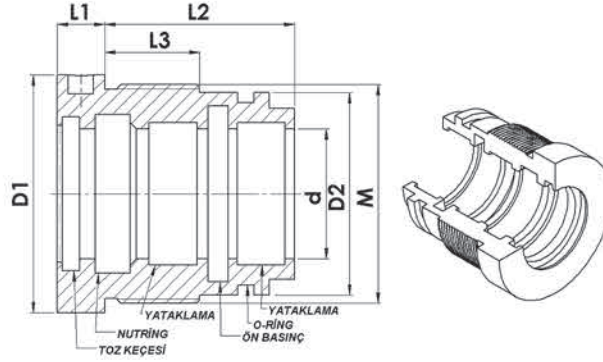

SN	ÜRÜN KODU	D1	D2	d	M.	L3	L2	L1	KEÇE KODU	TOZ KEÇESİ	NUTRİNG	YATAKLAMA	ÖN BASINÇ	O-RİNG
29	TCK075 035	90	76	35	M.81x2	30	60	15	KTCK075 035	35x43x7/5	35x45x8	35x40x15-(2)	YOK	68x4
30	TCK075 040	90	76	40	M.81x2	30	60	15	KTCK075 040	40x48x7/5	40x50x10	40x45x15-(2)	YOK	68x4
31	TCK075 045	90	76	45	M.81x2	30	60	15	KTCK075 045	45x55x7/5	45x55x10	45x50x15-(2)	45x60x6	68x4
32	TCK075 050	90	76	50	M.81x2	30	60	15	KTCK075 050	50x60x7/5	50x60x10	50x55x15-(2)	50x65x6	68x4
33	TCK075 055	90	76	55	M.81x2	30	60	15	KTCK075 055	55x65x7/5	55x65x10	55x60x15-(2)	55x70x6	68x4
34	TCK080 030	95	81	30	M.86x2	30	60	15	KTCK080 030	30x38x7/5	30x40x8	30x34x9,5-(2)	YOK	72x4
35	TCK080 035	95	81	35	M.86x2	30	60	15	KTCK080 035	35x43x7/5	35x45x8	35x40x15-(2)	YOK	72x4
36	TCK080 040	95	81	40	M.86x2	30	60	15	KTCK080 040	40x48x7/5	40x50x10	40x45x15-(2)	40x55x6	72x4
37	TCK080 045	95	81	45	M.86x2	30	60	15	KTCK080 045	45x55x7/5	45x55x10	45x50x15-(2)	45x60x6	72x4
38	TCK080 050	95	81	50	M.86x2	30	60	15	KTCK080 050	50x60x7/5	50x60x10	50x55x15-(2)	50x65x6	72x4
39	TCK080 055	95	81	55	M.86x2	30	60	15	KTCK080 055	55x65x7/5	55x65x10	55x60x15-(2)	55x70x6	72x4
40	TCK080 060	95	81	60	M.86x2	30	60	15	KTCK080 060	60x70x7/5	60x70x10	60x65x15-(2)	60x75x6	72x4
41	TCK085 040	100	86	40	M.91x2	30	60	15	KTCK085 040	40x48x7/5	40x50x10	40x45x15-(2)	40x55x6	78x4
42	TCK085 045	100	86	45	M.91x2	30	60	15	KTCK085 045	45x55x7/5	45x55x10	45x50x15-(2)	45x60x6	78x4
43	TCK085 050	100	86	50	M.91x2	30	60	15	KTCK085 050	50x60x7/5	50x60x10	50x55x15-(2)	50x65x6	78x4
44	TCK085 055	100	86	55	M.91x2	30	60	15	KTCK085 055	55x65x7/5	55x65x10	55x60x15-(2)	55x70x6	78x4
45	TCK085 060	100	86	60	M.91x2	30	60	15	KTCK085 060	60x70x7/5	60x70x10	60x65x15-(2)	60x75x6	78x4
46	TCK090 040	105	91	40	M.96x2	30	60	15	KTCK090 040	40x48x7/5	40x50x10	40x45x15-(2)	40x55x6	82x4
47	TCK090 045	105	91	45	M.96x2	30	60	15	KTCK090 045	45x55x7/5	45x55x10	45x50x15-(2)	45x60x6	82x4
48	TCK090 050	105	91	50	M.96x2	30	60	15	KTCK090 050	50x60x7/5	50x60x10	50x55x15-(2)	50x65x6	82x4
49	TCK090 055	105	91	55	M.96x2	30	60	15	KTCK090 055	55x65x7/5	55x65x10	55x60x15-(2)	55x70x6	82x4
50	TCK090 060	105	91	60	M.96x2	30	60	15	KTCK090 060	60x70x7/5	60x70x10	60x65x15-(2)	60x75x6	82x4
51	TCK090 065	105	91	65	M.96x2	30	60	15	KTCK090 065	65x75x7/5	65x75x10	65x70x15-(2)	65x80x6	82x4

TÜM İMALATLARIMIZ KASTAŞ KEÇE TOLERANSLARINA UYGUNDUR.

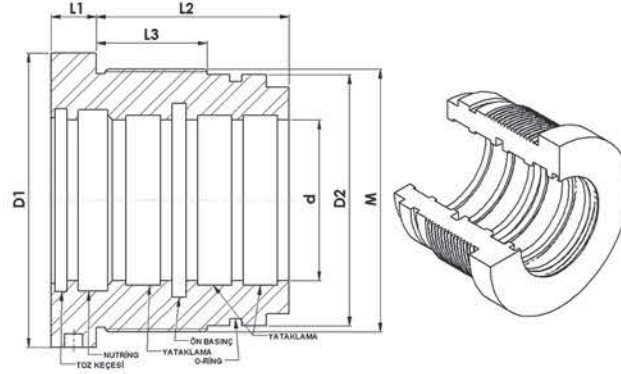

SN	ÜRÜN KODU	D1	D2	d	M.	L3	L2	L1	KEÇE KODU	TOZ KEÇESİ	NUTRİNG	YATAKLAMA	ÖN BASINÇ	O-RİNG
52	TCK100 035	115	101	35	M.106x2	49	85	20	KTCK100 035	35x43x7/5	35x45x8	35x40x15-(3)	YOK	92x4
53	TCK100 040	115	101	40	M.106x2	49	85	20	KTCK100 040	40x48x7/5	40x50x10	40x45x15-(3)	40x55x6	92x4
54	TCK100 045	115	101	45	M.106x2	49	85	20	KTCK100 045	45x55x7/5	45x55x10	45x50x15-(3)	45x60x6	92x4
55	TCK100 050	115	101	50	M.106x2	49	85	20	KTCK100 050	50x60x7/5	50x60x10	50x55x15-(3)	50x65x6	92x4
56	TCK100 055	115	101	55	M.106x2	49	85	20	KTCK100 055	55x65x7/5	55x65x10	55x60x15-(3)	55x70x6	92x4
57	TCK100 060	115	101	60	M.106x2	49	85	20	KTCK100 060	60x70x7/5	60x70x10	60x65x15-(3)	60x75x6	92x4
58	TCK100 065	115	101	65	M.106x2	49	85	20	KTCK100 065	65x75x7/5	65x75x10	65x70x15-(3)	65x80x6	92x4
59	TCK100 070	115	101	70	M.106x2	49	85	20	KTCK100 070	70x80x7/5	70x80x12	70x75x15-(3)	70x85x6	92x4
60	TCK100 075	115	101	75	M.106x2	49	85	20	KTCK100 075	75x87x12/7	75x85x12	75x80x15-(3)	75x90x6	92x4
61	TCK110 050	130	111	50	M.116x2	49	85	20	KTCK110 050	50x60x7/5	50x60x10	50x55x15-(3)	50x65x6	102x4
62	TCK110 055	130	111	55	M.116x2	49	85	20	KTCK110 055	55x65x7/5	55x65x10	55x60x15-(3)	55x70x6	102x4
63	TCK110 060	130	111	60	M.116x2	49	85	20	KTCK110 060	60x70x7/5	60x70x10	60x65x15-(3)	60x75x6	102x4
64	TCK110 065	130	111	65	M.116x2	49	85	20	KTCK110 065	65x75x7/5	65x75x10	65x70x15-(3)	65x80x6	102x4
65	TCK110 070	130	111	70	M.116x2	49	85	20	KTCK110 070	70x80x7/5	70x80x12	70x75x15-(3)	70x85x6	102x4
66	TCK110 075	130	111	75	M.116x2	49	85	20	KTCK110 075	75x87x12/7	75x85x12	75x80x15-(3)	75x90x6	102x4
67	TCK110 080	130	111	80	M.116x2	49	85	20	KTCK110 080	80x92x12/7	80x90x12	80x85x15-(3)	80x95x6	102x4
68	TCK115 060	135	116	60	M.121x2	49	85	20	KTCK115 060	60x70x7/5	60x70x10	60x65x15-(3)	60x75x6	108x4
69	TCK115 065	135	116	65	M.121x2	49	85	20	KTCK115 065	65x75x7/5	65x75x10	65x70x15-(3)	65x80x6	108x4
70	TCK115 070	135	116	70	M.121x2	49	85	20	KTCK115 070	70x80x7/5	70x80x12	70x75x15-(3)	70x85x6	108x4
71	TCK115 075	135	116	75	M.121x2	49	85	20	KTCK115 075	75x87x12/7	75x85x12	75x80x15-(3)	75x90x6	108x4
72	TCK115 080	135	116	80	M.121x2	49	85	20	KTCK115 080	80x92x12/7	80x90x12	80x85x15-(3)	80x95x6	108x4
73	TCK120 050	140	121	50	M.126x2	49	85	20	KTCK120 050	50x60x7/5	50x60x10	50x55x15-(3)	50x65x6	112x4
74	TCK120 055	140	121	55	M.126x2	49	85	20	KTCK120 055	55x65x7/5	55x65x10	55x60x15-(3)	55x70x6	112x4
75	TCK120 060	140	121	60	M.126x2	49	85	20	KTCK120 060	60x70x7/5	60x70x10	60x65x15-(3)	60x75x6	112x4
76	TCK120 065	140	121	65	M.126x2	49	85	20	KTCK120 065	65x75x7/5	65x75x10	65x70x15-(3)	65x80x6	112x4
77	TCK120 070	140	121	70	M.126x2	49	85	20	KTCK120 070	70x80x7/5	70x80x12	70x75x15-(3)	70x85x6	112x4
78	TCK120 075	140	121	75	M.126x2	49	85	20	KTCK120 075	75x87x12/7	75x85x12	75x80x15-(3)	75x90x6	112x4
79	TCK120 080	140	121	80	M.126x2	49	85	20	KTCK120 080	80x92x12/7	80x90x12	80x85x15-(3)	80x95x6	112x4
80	TCK120 085	140	121	85	M.126x2	49	85	20	KTCK120 085	85x97x12/7	85x95x12	85x90x15-(3)	85x100x6	112x4
81	TCK120 090	140	121	90	M.126x2	49	85	20	KTCK120 090	90x102x12/7	90x100x12	90x95x15-(3)	90x105x6	112x4

TÜM İMALATLARIMIZ KASTAŞ KEÇE TOLERANSLARINA UYGUNDUR.

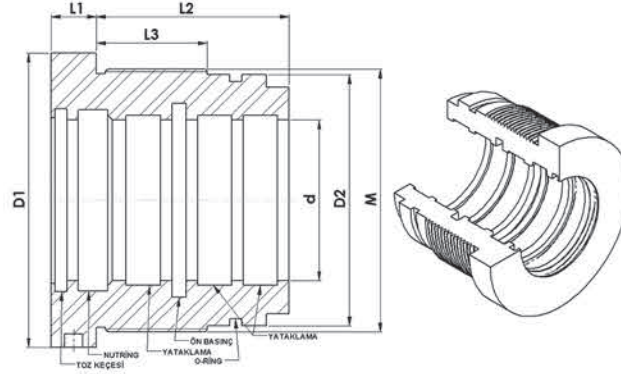

SN	ÜRÜN KODU	D1	D2	d	M	L3	L2	L1	KEÇE KODU	TOZ KEÇESİ	NUTRİNG	YATAKLAMA	ÖN BASINÇ	O-RİNG
82	TCK125 050	145	126	50	M.131x2	49	85	20	KTCK125 050	50x60x7/5	50x60x10	50x55x15-(3)	50x65x6	118x4
83	TCK125 055	145	126	55	M.131x2	49	85	20	KTCK125 055	55x65x7/5	55x65x10	55x60x15-(3)	55x70x6	118x4
84	TCK125 060	145	126	60	M.131x2	49	85	20	KTCK125 060	60x70x7/5	60x70x10	60x65x15-(3)	60x75x6	118x4
85	TCK125 065	145	126	65	M.131x2	49	85	20	KTCK125 065	65x75x7/5	65x75x10	65x70x15-(3)	65x80x6	118x4
86	TCK125 070	145	126	70	M.131x2	49	85	20	KTCK125 070	70x80x7/5	70x80x12	70x75x15-(3)	70x85x6	118x4
87	TCK125 075	145	126	75	M.131x2	49	85	20	KTCK125 075	75x87x12/7	75x85x12	75x80x15-(3)	75x90x6	118x4
88	TCK125 080	145	126	80	M.131x2	49	85	20	KTCK125 080	80x92x12/7	80x90x12	80x85x15-(3)	80x95x6	118x4
89	TCK125 085	145	126	85	M.131x2	49	85	20	KTCK125 085	85x97x12/7	85x95x12	85x90x15-(3)	85x100x6	118x4
90	TCK125 090	145	126	90	M.131x2	49	85	20	KTCK125 090	90x102x12/7	90x100x12	90x95x15-(3)	90x105x6	118x4
91	TCK125 100	145	126	90	M.131x2	49	85	20	KTCK125 100	100x112x12/7	100x120x12	100x105x15-(3)	100x115x6	118x4
92	TCK130 060	150	131	60	M.136x2	49	85	20	KTCK130 060	60x70x7/5	60x70x10	60x65x15-(3)	60x75x6	122x4
93	TCK130 070	150	131	70	M.136x2	49	85	20	KTCK130 070	70x80x7/5	70x80x12	70x75x15-(3)	70x85x6	122x4
94	TCK130 075	150	131	75	M.136x2	49	85	20	KTCK130 075	75x87x12/7	75x85x12	75x80x15-(3)	75x90x6	122x4
95	TCK130 080	150	131	80	M.136x2	49	85	20	KTCK130 080	80x92x12/7	80x90x12	80x85x15-(3)	80x95x6	122x4
96	TCK130 085	150	131	85	M.136x2	49	85	20	KTCK130 085	85x97x12/7	85x95x12	85x90x15-(3)	85x100x6	122x4
97	TCK130 090	150	131	90	M.136x2	49	85	20	KTCK130 090	90x102x12/7	90x100x12	90x95x15-(3)	90x105x6	122x4
98	TCK130 100	150	131	100	M.136x2	49	85	20	KTCK130 100	100x112x12/7	100x120x12	100x105x15-(3)	100x115x6	122x4
99	TCK140 070	160	141	70	M.146x2	49	85	20	KTCK140 070	70x80x7/5	70x80x12	70x75x15-(3)	70x85x6	132x4
100	TCK140 075	160	141	75	M.146x2	49	85	20	KTCK140 075	75x87x12/7	75x85x12	75x80x15-(3)	75x90x6	132x4
101	TCK140 080	160	141	80	M.146x2	49	85	20	KTCK140 080	80x92x12/7	80x90x12	80x85x15-(3)	80x95x6	132x4
102	TCK140 085	160	141	85	M.146x2	49	85	20	KTCK140 085	85x97x12/7	85x95x12	85x90x15-(3)	85x100x6	132x4
103	TCK140 090	160	141	90	M.146x2	49	85	20	KTCK140 090	90x102x12/7	90x100x12	90x95x15-(3)	90x105x6	132x4
104	TCK140 095	160	141	95	M.146x2	49	85	20	KTCK140 095	95x107x12/7	95x105x12	95x100x15-(3)	95x110x6	132x4
105	TCK140 100	160	141	100	M.146x2	49	85	20	KTCK140 100	100x112x12/7	100x120x12	100x105x15-(3)	100x115x6	132x4
106	TCK140 105	160	141	105	M.146x2	49	85	20	KTCK140 105	105x117x12/7	105x115x12	105x110x15-(3)	105x120x6	132x4
107	TCK140 110	160	141	110	M.146x2	49	85	20	KTCK140 110	110x122x12/7	110x125x12	110x115x15-(3)	110x125x6	132x4
108	TCK150 070	170	151	70	M.156x2	49	85	20	KTCK150 070	70x80x7/5	70x80x12	70x75x15-(3)	70x85x6	140x4
109	TCK150 080	170	151	80	M.156x2	49	85	20	KTCK150 080	80x92x12/7	80x90x12	80x85x15-(3)	80x95x6	140x4
110	TCK150 090	170	151	90	M.156x2	49	85	20	KTCK150 090	90x102x12/7	90x100x12	90x95x15-(3)	90x105x6	140x4
111	TCK150 100	170	151	100	M.156x2	49	85	20	KTCK150 100	100x112x12/7	100x120x12	100x105x15-(3)	100x115x6	140x4

TÜM İMALATLARIMIZ KASTAŞ KEÇE TOLERANSLARINA UYGUNDUR.

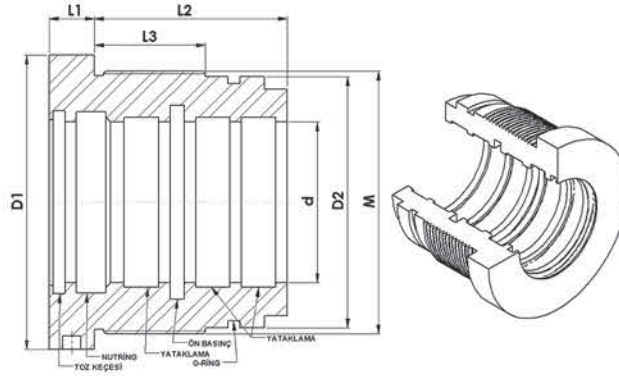

SN	ÜRÜN KODU	D1	D2	d	M.	L3	L2	L1	KEÇE KODU	TOZ KEÇESİ	NUTRİNG	YATAKLAMA	ÖN BASINÇ	O-RİNG
112	TCK160 060	180	161	60	M.166x2	49	85	20	KTCK160 060	60x70x7/5	60x70x10	60x65x15-(3)	60x75x6	150x4
113	TCK160 070	180	161	70	M.166x2	49	85	20	KTCK160 070	70x80x7/5	70x80x12	70x75x15-(3)	70x85x6	150x4
114	TCK160 080	180	161	80	M.166x2	49	85	20	KTCK160 080	80x92x12/7	80x90x12	80x85x15-(3)	80x95x6	150x4
115	TCK160 090	180	161	90	M.166x2	49	85	20	KTCK160 090	90x102x12/7	90x100x12	90x95x15-(3)	90x105x6	150x4
116	TCK160 100	180	161	100	M.166x2	49	85	20	KTCK160 100	100x112x12/7	100x120x12	100x105x15-(3)	100x115x6	150x4
117	TCK160 110	180	161	110	M.166x2	49	85	20	KTCK160 110	110x122x12/7	110x125x12	110x115x15-(3)	110x125x6	150x4
118	TCK160 120	180	161	120	M.166x2	49	85	20	KTCK160 120	120x132x12/7	120x140x14.6	120x125x15-(3)	120x135x6	150x4
119	TCK170 100	200	171	100	M.176x2	49	85	20	KTCK170 100	100x112x12/7	100x120x12	100x105x15-(3)	100x115x6	160x4
120	TCK170 110	200	171	110	M.176x2	49	85	20	KTCK170 110	110x122x12/7	110x125x12	110x115x15-(3)	110x125x6	160x4
121	TCK170 120	200	171	120	M.176x2	49	85	20	KTCK170 120	120x132x12/7	120x140x14.6	120x125x15-(3)	120x135x6	160x4
122	TCK180 080	210	181	80	M.186x2	49	85	20	KTCK180 080	80x92x12/7	80x90x12	80x85x15-(3)	80x95x6	170x4
123	TCK180 090	210	181	90	M.186x2	49	85	20	KTCK180 090	90x102x12/7	90x100x12	90x95x15-(3)	90x105x6	170x4
124	TCK180 100	210	181	100	M.186x2	49	85	20	KTCK180 100	100x112x12/7	100x120x12	100x105x15-(3)	100x115x6	170x4
125	TCK180 110	210	181	110	M.186x2	49	85	20	KTCK180 110	110x122x12/7	110x125x12	110x115x15-(3)	110x125x6	170x4
126	TCK180 120	210	181	120	M.186x2	49	85	20	KTCK180 120	120x132x12/7	120x140x14.6	120x125x15-(3)	120x135x6	170x4
127	TCK180 130	210	181	130	M.186x2	49	85	20	KTCK180 130	130x142x12/7	130x150x15	130x135x15-(3)	130x145x6	170x4
128	TCK180 140	210	181	140	M.186x2	49	85	20	KTCK180 140	140x150x12/7	140x160x13	140x145x15-(3)	140x155x6	170x4
129	TCK200 080	230	201	80	M.207x2	49	85	20	KTCK200 080	80x92x12/7	80x90x12	80x85x15-(3)	80x95x6	190x4
130	TCK200 090	230	201	90	M.207x2	49	85	20	KTCK200 090	90x102x12/7	90x100x12	90x95x15-(3)	90x105x6	190x4
131	TCK200 100	230	201	100	M.207x2	49	85	20	KTCK200 100	100x112x12/7	100x120x12	100x105x15-(3)	100x115x6	190x4
132	TCK200 110	230	201	110	M.207x2	49	85	20	KTCK200 110	110x122x12/7	110x125x12	110x115x15-(3)	110x125x6	190x4
133	TCK200 120	230	201	120	M.207x2	49	85	20	KTCK200 120	120x132x12/7	120x140x14.6	120x125x15-(3)	120x135x6	190x4
134	TCK200 130	230	201	130	M.207x2	49	85	20	KTCK200 130	130x142x12/7	130x150x15	130x135x15-(3)	130x145x6	190x4
135	TCK200 140	230	201	140	M.207x2	49	85	20	KTCK200 140	140x150x12/7	140x160x13	140x145x15-(3)	140x155x6	190x4
136	TCK220 100	270	221	100	M.207x2	49	85	20	KTCK220 100	100x112x12/7	100x120x12	100x105x15-(3)	100x115x6	210x4
137	TCK220 110	270	221	110	M.226x2	49	85	20	KTCK220 110	110x122x12/7	110x125x12	110x115x15-(3)	110x125x6	210x4
138	TCK220 120	270	221	120	M.226x2	49	85	20	KTCK220 120	120x132x12/7	120x140x14.6	120x125x15-(3)	120x135x6	210x4
139	TCK220 130	270	221	130	M.226x2	49	85	20	KTCK220 130	130x142x12/7	130x150x15	130x135x15-(3)	130x145x6	210x4
140	TCK220 140	270	221	140	M.226x2	49	85	20	KTCK220 140	140x150x12/7	140x160x13	140x145x15-(3)	140x155x6	210x4
141	TCK220 150	270	221	150	M.226x2	49	85	20	KTCK220 150	150x162x12/7	150x170x14	150x155x15-(3)	150x165x6	210x4
142	TCK220 160	270	221	160	M.226x2	49	85	20	KTCK220 160	160x172x12/7	160x180x15	160x165x15-(3)	YOK	210x4

TÜM İMALATLARIMIZ KASTAŞ KEÇE TOLERANSLARINA UYGUNDUR.

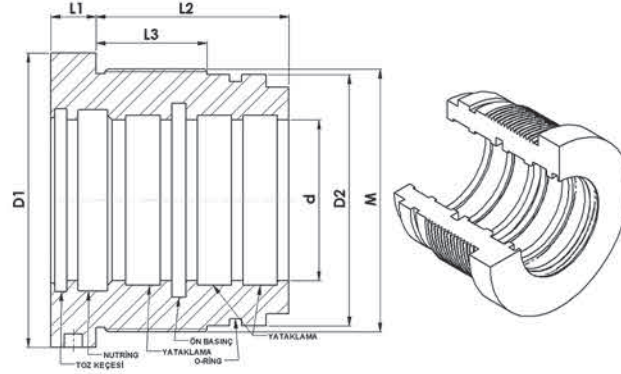

SN	ÜRÜN KODU	D1	D2	d	M.	L3	L2	L1	KEÇE KODU	TOZ KEÇESİ	NUTRİNG	YATAKLAMA	ÖN BASIYI	O-RİNG
143	TCK230 140	280	231	140	M.236x2	49	85	20	KTCK230 140	140x150x12/7	140x160x13	140x145x15-(3)	140x155x6	220x4
144	TCK230 150	280	231	150	M.236x2	49	85	20	KTCK230 150	150X162X12/7	150X170X14	150X155X15-(3)	150x165X6	220x4
145	TCK230 160	280	231	160	M.236x2	49	85	20	KTCK230 160	160x172x12/7	160x180x15	160x165x15-(3)	YOK	220x4
146	TCK250 100	280	251	100	M.256x2	49	85	20	KTCK250 100	100x112x12/7	100x120x12	100x105x15-(3)	100x115x6	240x4
147	TCK250 110	280	251	110	M.256x2	49	85	20	KTCK250 110	110x122x12/7	110x125x12	110x115x15-(3)	110x125x6	240x4
148	TCK250 120	300	251	120	M.256x2	49	85	20	KTCK250 120	120x132x12/7	120x140x14.6	120X125X15-(3)	120x135X6	240x4
149	TCK250 130	300	251	130	M.256x2	49	85	20	KTCK250 130	130X142X12/7	130X150X15	130X135X15-(3)	130x145x6	240x4
150	TCK250 140	300	251	140	M.256x2	49	85	20	KTCK250 140	140x150x12/7	140x160x13	140x145x15-(3)	140x155x6	240x4
151	TCK250 150	300	251	150	M.256x2	49	85	20	KTCK250 150	150X162X12/7	150X170X14	150X155X15-(3)	150x165X6	240x4
152	TCK250 160	300	251	160	M.256x2	49	85	20	KKTCK250 160	160x172x12/7	160x180x15	160x165x15-(3)	YOK	240x4

TÜM İMALATLARIMIZ KASTAŞ KEÇE TOLERANSLARINA UYGUNDUR.

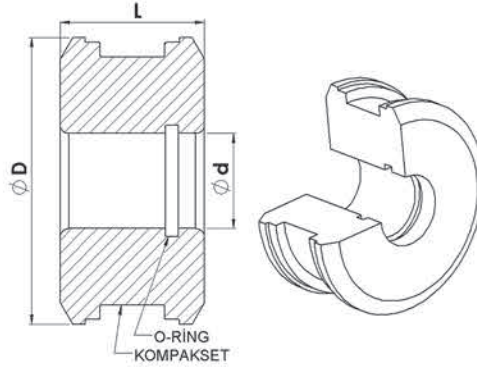

S.N	ÜRÜN KODU	D	d	L	KEÇE KODU	KOMPAKSET	O-RİNG
1	TPD025	25	10	35	KTPD025	25x16x13,5x2.1	10x3
2	TPD032	32	15	40	KTPD032	32x24x15,5x3,10	15x3
3	TPD035	35	15	40	KTPD035	35x25x16,4x6,35	15x3
4	TPD040	40	15	40	KTPD040	40x30x16,4x6,35	15x3
5	TPD045	45	15	40	KTPD045	45x035x16,4x6,35	15x3
6	TPD050	50	20	40	KTPD050	50x38x20,5x4,2	20,22x3,53
7	TPD055	55	20	40	KTPD055	55x39x20,5x3,1	20,22x3,53
8	TPD060	60	24	40	KTPD060	60x48x20,5x4,2	23,40x3,53
9	TPD063	63	24	40	KTPD063	63x051x20,5x4,2	23,40x3,53
10	TPD065	65	24	40	KTPD065	65x049x20,5x3,1	23,40x3,53
11	TPD070	70	24	40	KTPD070	70x054x20,5x3,1	23,40x3,53
12	TPD075	75	24	50	KTPD075	75x55x22,4x6,35	23,40x3,53
13	TPD080	80	27	50	KTPD080	80x66x22,4x5,2	26,58x3,53
14	TPD085	85	27	50	KTPD085	85x65x22,4x6,35	26,58x3,53
15	TPD090	90	27	50	KTPD090	90x076x22,4x5,2	26,58x3,53
16	TPD100	100	33	50	KTPD100	100x86x22,4x5,2	32,92x3,53
17	TPD110	110	40	50	KTPD110	110x096x22,4x5,2	40x4
18	TPD115	115	40	50	KTPD115	115x101x22,4x5,2	40x4
19	TPD120	120	40	50	KTPD120	120x106x22,4x5,2	40x4
20	TPD125	125	40	50	KTPD125	125x103x26,5x5,1	40x4
21	TPD130	130	40	58	KTPD130	130x105x25,4x6,35	40x4
22	TPD140	140	40	58	KTPD140	140x123x26,5x7,2	40x4
23	TPD150	150	40	58	KTPD150	150x125x25,4x6,35	40x4
24	TPD160	160	51	58	KTPD160	160x143x26,5x7,2	50x5
25	TPD170	170	51	58	KTPD170	170x148x26,5x5,10	50x5
26	TPD180	180	51	58	KTPD180	180x163x26,5x7,2	50x5
27	TPD200	200	51	69	KTPD200	200x180x31,5x9,2	50x5
28	TPD220	220	60	69	KTPD220	220x200x31,5	60x5
29	TPD230	230	70	70	KTPD230	230x205x25,40	70x5
30	TPD250	250	80	70	KTPD250	250x225x25,4	80x5

TÜM İMALATLARIMIZ KASTAŞ KEÇE TOLERANSLARINA UYGUNDUR.

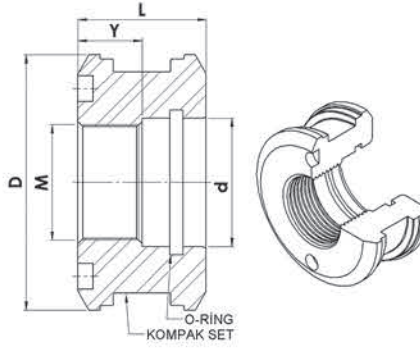

S.N	ÜRÜN KODU	D	d	M	Y	L	KEÇE KODU	KOMPAKSET	O-RİNG
1	TPY032	32	18	M.16x1,5	20	40	KTPY032	32x24x15,5x3,10	18x3
2	TPY035	35	18	M.16x1,5	20	40	KTPY035	35x25x16,4x6,35	18x3
3	TPY040	40	22	M.20x1,5	20	40	KTPY040	40x30x16,4x6,35	22x3
4	TPY045	45	22	M.20x1,5	20	40	KTPY045	45x35x16,4x6,35	22x3
5	TPY050	50	25	M.22x1,5	20	40	KTPY050	50x38x20,5x4,2	25x3
6	TPY055	55	25	M.22x1,5	20	40	KTPY055	55x39x20,5x3,1	25x3
7	TPY060	60	35	M.26x1,5	20	40	KTPY060	60x48x20,5x4,2	35x3
8	TPY063	63	35	M.30x1,5	20	40	KTPY063	63x51x20,5x4,2	35x3
9	TPY065	65	35	M.30x1,5	20	40	KTPY065	65x49x20,5x3,1	35x3
10	TPY070	70	40	M.35x1,5	20	40	KTPY070	70x54x20,5x3,1	40x3
11	TPY075	75	40	M.35x1,5	25	50	KTPY075	75x55x22,4x6,35	40x3
12	TPY080	80	40	M.35x1,5	25	50	KTPY080	80x66x22,4x5,2	40x3
13	TPY085	85	40	M.35x1,5	25	50	KTPY085	85x65x22,4x6,35	40x3
14	TPY090	90	50	M.45x1,5	25	50	KTPY090	90x76x22,4x5,2	50x4
15	TPY100	100	50	M.45x1,5	25	50	KTPY100	100x86x22,4x5,2	50x4
16	TPY110	110	50	M.45x1,5	25	50	KTPY110	110x96x22,4x5,2	50x4
17	TPY115	115	50	M.45x1,5	25	50	KTPY115	115x101x22,4x5,2	50x4
18	TPY120	120	60	M.50x1,5	25	50	KTPY120	120x106x22,4x5,2	60x4
19	TPY125	125	60	M.50X2	25	50	KTPY125	125x103x26,5x5,1	60x4
20	TPY130	130	70	M.60X2	29	58	KTPY130	130x105x25,4x6,35	70x4
21	TPY140	140	70	M.60X2	29	58	KTPY140	140x123x26,5x7,2	70x4
22	TPY150	150	70	M.60X2	29	58	KTPY150	150x125x25,4x6,35	70x4
23	TPY160	160	80	M.70x2	29	58	KTPY160	160x143x26,5x7,2	80x5
24	TPY170	170	80	M.70x2	29	58	KTPY170	170x148x26,5x5,10	80x5
25	TPY180	180	90	M.80X2	29	58	KTPY180	180x163x26,5x7,2	90x5
26	TPY200	200	90	M.80X2	35	69	KTPY200	200x180x31,5x9,2	90x5
27	TPY220	220	90	M.80X2	35	70	KTPY220	220x200x31,5	80x5
28	TPY230	230	115	M.110x2	35	70	KTPY230	230x205x25,40	100x5
29	TPY250	250	120	M.115x2	35	70	KTPY250	250x225x25,4	110x5

TÜM İMALATLARIMIZ KASTAŞ KEÇE TOLERANSLARINA UYGUNDUR.

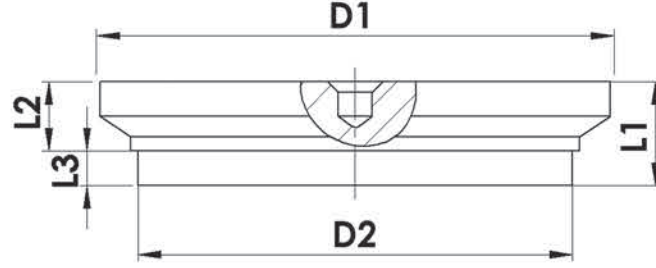

S.N	ÜRÜN KODU	D1	D2	L1	L2	L3
1	TAK032 040	40	32	15	10	5
2	TAK035 045	45	35	15	10	5
3	TAK040 050	50	40	15	10	5
4	TAK045 055	55	45	15	10	5
5	TAK050 060	60	50	15	10	5
6	TAK050 065	65	50	15	10	5
7	TAK055 065	65	55	15	10	5
8	TAK060 070	70	60	15	10	5
9	TAK060 080	80	60	15	10	5
10	TAK063 075	75	63	15	10	5
11	TAK065 080	80	65	15	10	5
12	TAK070 080	80	70	15	10	5
13	TAK070 085	85	70	15	10	5
14	TAK075 085	85	75	15	10	5
15	TAK075 090	90	75	15	10	5
16	TAK080 095	95	80	15	10	5
17	TAK080 100	100	80	15	10	5
18	TAK085 100	100	85	15	10	5
19	TAK090 105	105	90	20	15	5
20	TAK090 110	110	90	20	15	5
21	TAK100 115	115	100	20	15	5
22	TAK100 120	120	100	20	15	5
23	TAK110 130	130	110	20	15	5
24	TAK115 130	130	115	20	15	5
25	TAK115 135	135	115	20	15	5
26	TAK120 140	140	120	20	15	5
27	TAK120 145	145	125	25	20	5
28	TAK125 145	145	125	25	20	5
29	TAK125 150	150	125	25	20	5
30	TAK130 150	150	130	25	20	5
31	TAK140 160	160	140	25	20	5
32	TAK140 165	165	140	25	20	5
33	TAK140 170	170	140	25	20	5

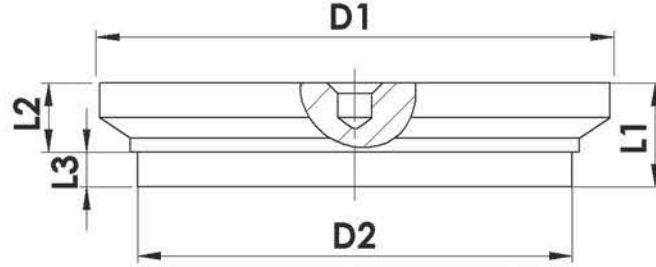

S.N	ÜRÜN KODU	D1	D2	L1	L2	L3
34	TAK150 170	170	150	25	20	5
35	TAK150 180	180	150	25	20	5
36	TAK160 180	180	160	30	25	5
37	TAK160 185	185	160	30	25	5
38	TAK160 190	190	160	30	25	5
39	TAK170 200	200	170	30	25	5
40	TAK180 210	210	180	30	25	5
41	TAK200 240	240	200	30	25	5
42	TAK200 245	245	200	30	25	5
43	TAK220 270	270	220	30	25	5
44	TAK230 280	280	230	30	25	5
45	TAK250 300	300	250	35	30	5

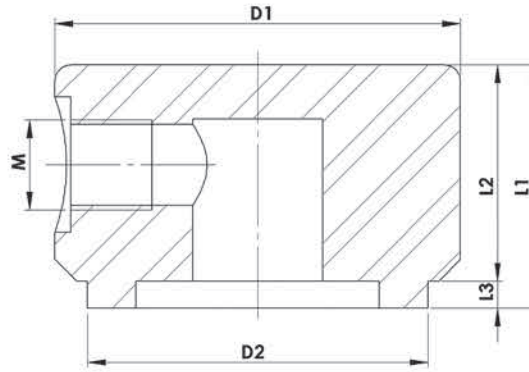

S.N	ÜRÜN KODU	D1	D2	M	L1	L2	L3
1	TYAK032 040	40	32	1/4"	45	40	5
2	TYAK040 050	50	40	1/4"	45	40	5
3	TYAK050 060	60	50	3/8"	45	40	5
4	TYAK060 070	70	60	3/8"	45	40	5
5	TYAK063 075	75	63	3/8"	45	40	5
6	TYAK065 080	80	65	3/8"	45	40	5
7	TYAK070 085	85	70	3/8"	45	40	5
8	TYAK075 090	90	75	3/8"	45	40	5
9	TYAK080 095	95	80	3/8"	45	40	5
10	TYAK080 100	100	80	3/8"	45	40	5
11	TYAK085 100	100	85	3/8"	45	40	5
12	TYAK090 105	105	90	3/8"	45	40	5
13	TYAK090 110	110	90	3/8"	45	40	5
14	TYAK100 115	115	100	1/2"	45	40	5
15	TYAK100 120	120	100	1/2"	45	40	5
16	TYAK110 130	130	110	1/2"	45	40	5
17	TYA115 130	130	115	1/2"	45	40	5
18	TYAK120 140	140	120	1/2"	45	40	5
19	TYAK120 145	145	120	1/2"	45	40	5
20	TYAK125 145	145	125	1/2"	45	40	5
21	TYAK125 150	150	125	1/2"	45	40	5
22	TYAK130 150	150	130	1/2"	45	40	5
23	TYAK140 160	160	140	1/2"	45	40	5
24	TYAK150 170	170	150	1/2"	45	40	5
25	TYAK150 180	180	150	1/2"	45	40	5
26	TYAK160 180	180	160	1/2"	45	40	5
27	TYAK160 190	190	160	1/2"	45	40	5
28	TYAK170 200	200	170	1/2"	45	40	5
29	TYAK180 210	210	180	1/2"	45	40	5
30	TYAK200 230	230	200	1/2"	45	40	5
31	TYAK200 240	240	200	1/2"	45	40	5
32	TYAK230 280	280	230	1/2"	45	40	5

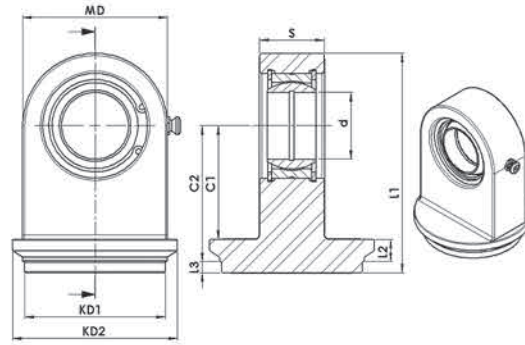

S.N	ÜRÜN KODU	KD1	KD2	d	L1	L2	L3	C1	C2	MD	S
1	KM040 050 020	40	50	20	78	10	5	38	48	50	18
2	KM050 060 025	50	60	25	87,5	10	5	45	55	55	23
3	KM060 070 030	60	70	30	98,5	10	5	51	61	65	29
4	KM063 075 030	63	75	30	98,5	10	5	51	61	65	29
5	KM070 085 035	70	85	35	117,5	10	5	61	71	83	30
6	KM080 095 035	80	95	35	117,5	10	5	61	71	83	30
7	KM080 100 035	80	100	35	117,5	10	5	61	71	83	30
8	KM090 105 040	90	105	40	139	15	5	69	84	101	35
9	KM100 115 040	100	115	40	139	15	5	69	84	101	35
10	KM100 120 040	100	120	40	139	15	5	69	84	101	35

HİDROLİK SİLİNDİR DİKDÖRTGEN TİP KAYNAKLIK MAFSAL
HYDRAULIC CYLINDER RECTANGLE TYPE JOINT FOR WELDING

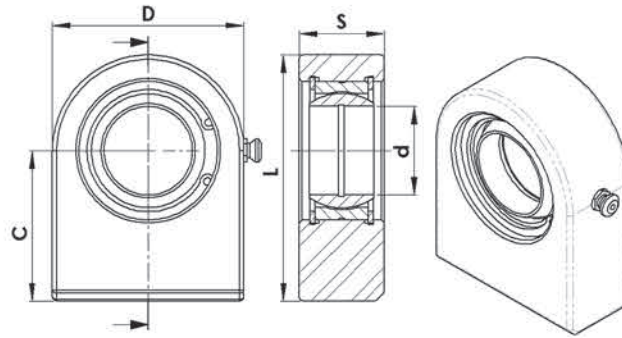

S.N	ÜRÜN KODU	d	D	L	C	S
1	RMK 20	20	50	63	38	19
2	RMK 25	25	55	72,5	45	23
3	RMK 30	30	65	83,5	51	28
4	RMK 35	35	83	102,5	61	30
5	RMK 40	40	101	119	69	35
6	RMK 45	45	111	132	77	40
7	RMK 50	50	123	149,5	88	40
8	RMK 60	60	140	170	100	50
9	RMK 70	70	164	197	115	55

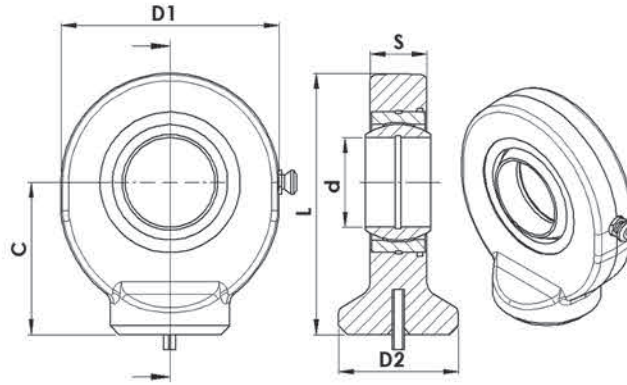

S.N	ÜRÜN KODU	d	D1	L	C	S	D2
1	RMY 20	20	53	64,5	38	16	27,5
2	RMY 25	25	64	77	45	20	33,5
3	RMY 30	30	73	87,5	51	22	40
4	RMY 35	35	82	102	61	25	47
5	RMY 40	40	92	115	69	28	52
6	RMY 45	45	102	128	77	32	58
7	RMY 50	50	112	144	88	35	62
8	RMY 60	60	137	167,5	100	44	70

HİDROLİK SİLİNDİR VİDALI TİP MAFSAL - HYDRAULIC CYLINDER JOINT WITH SCREW

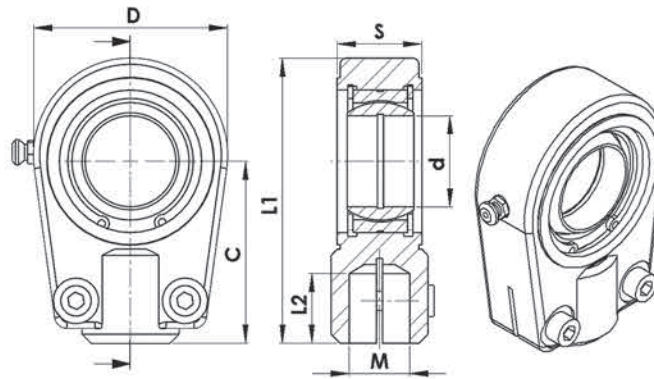

S.N	ÜRÜN KODU	d	D	L1	S	C	M	L2
1	RMV 20	20	56	80	19	50	M.16x1,5	17
2	RMV 25	25	56	80	23	50	M.16x1,5	17
3	RMV 30	30	64	94	28	60	M.22x1,5	23
4	RMV 35	35	78	112	30	70	M.28x1,5	29
5	RMV 40	40	94	135	35	85	M.35x1,5	36
6	RMV 50	50	116	168	40	105	M.45x1,5	46
7	RMV 60	60	130	200	50	130	M.58x1,5	59
8	RMV 70	70	157	232	55	150	M.65x1,5	66

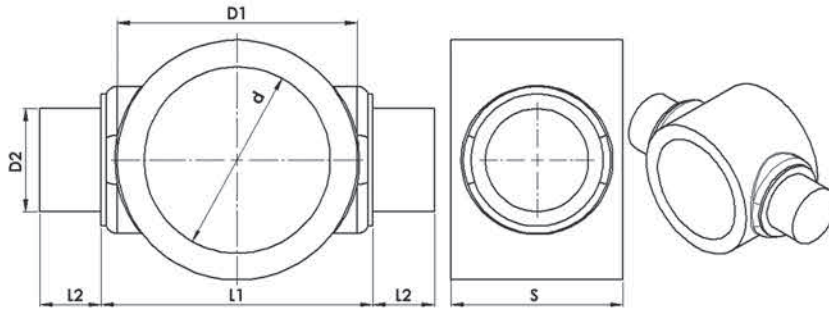

S.N	ÜRÜN KODU	d	D1	D2	L1	L2	S
1	BŞK076	76	97	42	111	25	70
2	BŞK086	86	108	42	123	25	70
3	BŞK096	96	118	42	131	25	70
4	BŞK106	106	126	42	141	25	70
5	BŞK116	116	136	42	152	25	70
6	BŞK121	121	142	42	156	25	70
7	BŞK131	131	151	42	166	25	70
8	BŞK141	141	165	42	178	25	70
9	BŞK151	151	175	42	187	25	70

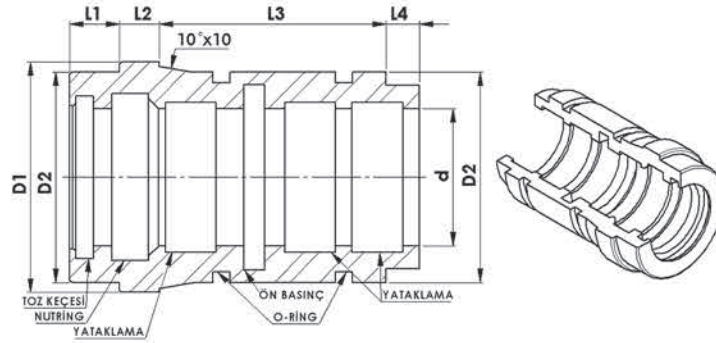

S.N	ÜRÜN KODU	D1	D2	d	L1	L2	L3	L4	KEÇE KODU	TOZ KEÇESİ	NUTRING	YATAKLAMA	ÖN BASINÇ	O-RİNG
1	TKR050 030	56	50	31	12	12	50	6	KTKR050 030	30x38x7/5	30x40x8	30x34x9,5-(2)	YOK	45x3-(2)
2	TKR050 035	56	50	36	12	12	50	6	KTKR050 035	35x43x7/5	35x45x8	35x40x15-(2)	YOK	45x3-(2)
3	TKR063 040	69	63	41	15	12	68	10	KTKR063 040	40x48x7/5	40x50x10	40x45x15-(3)	40x55x6	56x4-(2)
4	TKR063 045	69	63	46	15	12	68	10	KTKR063 045	45x55/7/5	45x55x10	45x50x15-(3)	YOK	56x4-(2)
5	TKR070 040	79	70	41	15	12	68	10	KTKR070 040	40x48x7/5	40x50x10	40x45x15-(3)	40x55x6	62x4-(2)
6	TKR070 045	79	70	46	15	12	68	10	KTKR070 045	45x55/7/5	45x55x10	45x50x15-(3)	45x60x6	62x4-(2)
7	TKR070 050	79	70	51	15	12	68	10	KTKR070 050	50x60x7/5	50x60x10	50x55x15-(3)	YOK	62x4-(2)
8	TKR070 055	79	70	56	15	12	68	10	KTKR070 055	55x65x7/5	55x65x10	55x60x15-(3)	YOK	62x4-(2)
9	TKR075 045	86	75	46	15	12	68	10	KTKR075 045	45x55/7/5	45x55x10	45x50x15-(3)	45x60x6	68x4-(2)
10	TKR075 050	86	75	51	15	12	68	10	KTKR075 050	50x60x7/5	50x60x10	50x55x15-(3)	50x65x6	68x4-(2)
11	TKR080 040	89	80	41	15	12	68	10	KTKR080 040	40x48x7/5	40x50x10	40x45x15-(3)	40x55x6	72x4-(2)
12	TKR080 045	89	80	46	15	12	68	10	KTKR080 045	45x55/7/5	45x55x10	45x50x15-(3)	45x60x6	72x4-(2)
13	TKR080 050	89	80	51	15	12	68	10	KTKR080 050	50x60x7/5	50x60x10	50x55x15-(3)	50x65x6	72x4-(2)
14	TKR080 055	89	80	56	15	12	68	10	KTKR080 055	55x65x7/5	55x65x10	55x60x15-(3)	55x70x6	72x4-(2)
15	TKR080 060	89	80	61	15	12	68	10	KTKR080 060	60x70x7/5	60x70x10	60x65x15-(3)	YOK	82x4-(2)
16	TKR090 040	99	90	41	15	12	68	10	KTKR090 040	40x48x7/5	40x50x10	40x45x15-(3)	40x55x6	82x4-(2)
17	TKR090 045	99	90	46	15	12	68	10	KTKR090 045	45x55x7/5	45x55x10	45x50x15-(3)	45x60x6	82x4-(2)
18	TKR090 050	99	90	51	15	12	68	10	KTKR090 050	50x60x7/5	50x60x10	50x55x15-(3)	50x65x6	82x4-(2)
19	TKR090 055	99	90	56	15	12	68	10	KTKR090 055	55x65x7/5	55x65x10	55x60x15-(3)	55x70x6	82x4-(2)
20	TKR090 060	99	90	61	15	12	68	10	KTKR090 060	60x70x7/5	60x70x10	60x65x15-(3)	60x75x6	82x4-(2)
21	TKR090 065	99	90	66	15	12	68	10	KTKR090 065	65x75x7/5	65x75x10	65x70x15-(3)	65x80x6	82x4-(2)
22	TKR090 070	99	90	71	15	12	68	10	KTKR090 070	70x80x7/5	70x80x12	70x75x15-(3)	YOK	82x4-(2)
23	TKR100 040	109	100	41	15	12	68	10	KTKR100 040	40x48x7/5	40x50x10	40x45x15-(3)	40x55x6	92x4-(2)
24	TKR100 050	109	100	51	15	12	68	10	KTKR100 050	50x60x7/5	50x60x10	50x55x15-(3)	50x65x6	92x4-(2)
25	TKR100 055	109	100	56	15	12	68	10	KTKR100 055	55x65x7/5	55x65x10	55x60x15-(3)	55x70x6	92x4-(2)
26	TKR100 060	109	100	61	15	12	68	10	KTKR100 060	60x70x7/5	60x70x10	60x65x15-(3)	60x75x6	92x4-(2)
27	TKR100 065	109	100	66	15	12	68	10	KTKR100 065	65x75x7/5	65x75x10	65x70x15-(3)	65x80x6	92x4-(2)
28	TKR100 070	109	100	71	15	12	68	10	KTKR100 070	70x80x7/5	70x80x12	70x75x15-(3)	70x85x6	92x4-(2)
29	TKR100 075	109	100	76	15	12	68	10	KTKR100 075	75x87x12/7	75x85x12	75x80x15-(3)	75x90x6	92x4-(2)
30	TKR100 080	109	100	81	15	12	68	10	KTKR100 080	80x92x12/7	80x90x12	80x85x15-(3)	YOK	92x4-(2)

TÜM İMALATLARIMIZ KASTAŞ KEÇE TOLERANSLARINA UYGUNDUR.

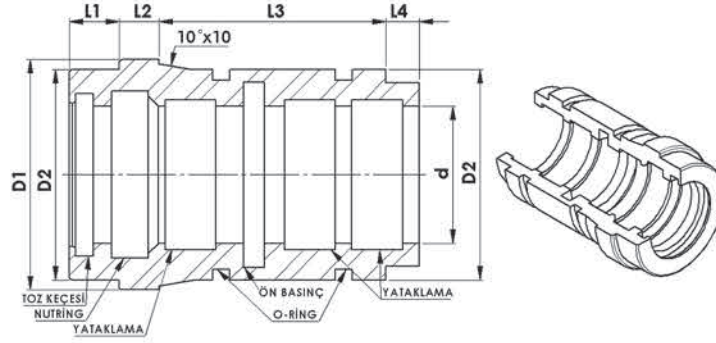

S.N	ÜRÜN KODU	D1	D2	d	L1	L2	L3	L4	KEÇE KODU	TOZ KEÇESİ	NUTRİNG	YATAKLAMA	ÖN BASINÇ	O-RİNG
31	TKR110 050	124	110	51	15	12	68	10	KTKR110 050	50x60x7/5	50x60x10	50x55x15-(3)	50x65x6	102x4-(2)
32	TKR110 055	124	110	56	15	12	68	10	KTKR110 055	55x65x7/5	55x65x10	55x60x15-(3)	55x70x6	102x4-(2)
33	TKR110 060	124	110	61	15	12	68	10	KTKR110 060	60x70x7/5	60x70x10	60x65x15-(3)	60x75x6	102x4-(2)
34	TKR110 065	124	110	66	15	12	68	10	KTKR110 065	65x75x7/5	65x75x10	65x70x15-(3)	65x80x6	102x4-(2)
35	TKR110 070	124	110	71	15	12	68	10	KTKR110 070	70x80x7/5	70x80x12	70x75x15-(3)	70x85x6	102x4-(2)
36	TKR110 075	124	110	76	15	12	68	10	KTKR110 075	75x87x12/7	75x85x12	75x80x15-(3)	75x90x6	102x4-(2)
37	TKR110 080	124	110	81	15	12	68	10	KTKR110 080	80x92x12/7	80x90x12	80x85x15-(3)	80x95x6	102x4-(2)
38	TKR110 085	124	110	86	15	12	68	10	KTKR110 085	85x97x12/7	85x95x12	85x90x15-(3)	85x100x6	102x4-(2)
39	TKR115 060	128	115	61	15	12	68	10	KTKR115 060	60x70x7/5	60x70x10	60x65x15-(3)	60x75x6	108x4-(2)
40	TKR115 065	128	115	66	15	12	68	10	KTKR115 065	65x75x7/5	65x75x10	65x70x15-(3)	65x80x6	108x4-(2)
41	TKR115 070	128	115	71	15	12	68	10	KTKR115 070	70x80x7/5	70x80x12	70x75x15-(3)	70x85x6	108x4-(2)
42	TKR115 075	128	115	76	15	12	68	10	KTKR115 075	75x87x12/7	75x85x12	75x80x15-(3)	75x90x6	108x4-(2)
43	TKR115 080	128	115	81	15	12	68	10	KTKR115 080	80x92x12/7	80x90x12	80x85x15-(3)	80x95x6	108x4-(2)
44	TKR120 060	132	120	61	15	12	68	10	KTKR120 060	60x70x7/5	60x70x10	60x65x15-(3)	60x75x6	112x4-(2)
45	TKR120 065	132	120	66	15	12	68	10	KTKR120 065	65x75x7/5	65x75x10	65x70x15-(3)	65x80x6	112x4-(2)
46	TKR120 070	132	120	71	15	12	68	10	KTKR120 070	70x80x7/5	70x80x12	70x75x15-(3)	70x85x6	112x4-(2)
47	TKR120 075	132	120	76	15	12	68	10	KTKR120 075	75x87x12/7	75x85x12	75x80x15-(3)	75x90x6	112x4-(2)
48	TKR120 080	132	120	81	15	12	68	10	KTKR120 080	80x92x12/7	80x90x12	80x85x15-(3)	80x95x6	112x4-(2)
49	TKR120 085	132	120	86	15	12	68	10	KTKR120 085	85x97x12/7	85x95x12	85x90x15-(3)	85x100x6	112x4-(2)
50	TKR120 090	132	120	91	15	12	68	10	KTKR120 090	90x102x12/7	90x100x12	90x95x15-(3)	90x105x6	112x4-(2)
51	TKR125 070	138	125	71	15	12	68	10	KTKR125 070	70x80x7/5	70x80x12	70x75x15-(3)	70x85x6	118x4-(2)
52	TKR125 075	138	125	76	15	12	68	10	KTKR125 075	75x87x12/7	75x85x12	75x80x15-(3)	75x90x6	118x4-(2)
53	TKR125 080	138	125	81	15	12	68	10	KTKR125 080	80x92x12/7	80x90x12	80x85x15-(3)	80x95x6	118x4-(2)
54	TKR125 085	138	125	86	15	12	68	10	KTKR125 085	85x97x12/7	85x95x12	85x90x15-(3)	85x100x6	118x4-(2)
55	TKR125 090	138	125	91	15	12	68	10	KTKR125 090	90x102x12/7	90x100x12	90x95x15-(3)	90x105x6	118x4-(2)
56	TKR125 100	138	125	101	15	12	68	10	KTKR125 100	100x112x12/7	100x120x12	100x105x15-(3)	100x115x6	118x4-(2)

TÜM İMALATLARIMIZ KASTAŞ KEÇE TOLERANSLARINA UYGUNDUR.

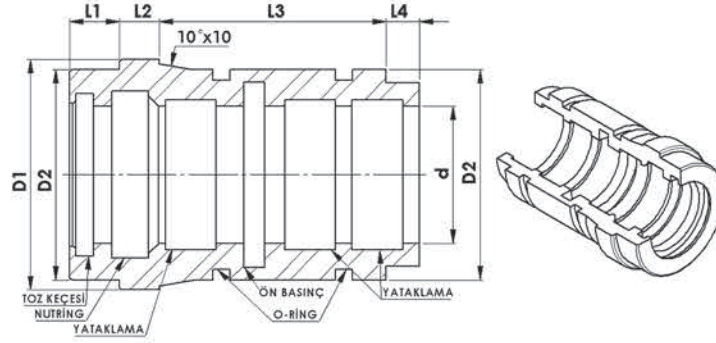

S.N	ÜRÜN KODU	D1	D2	d	L1	L2	L3	L4	KEÇE KODU	TOZ KEÇESİ	NUTRİNG	YATAKLAMA	ÖN BASINÇ	O-RİNG
57	TKR130 070	142	130	71	15	12	68	10	KTKR130 070	70x80x7/5	70x80x12	70x75x15-(3)	70x85x6	122x4-(2)
58	TKR130 075	142	130	76	15	12	68	10	KTKR130 075	75x87x12/7	75x85x12	75x80x15-(3)	75x90x6	122x4-(2)
59	TKR130 080	142	130	81	15	12	68	10	KTKR130 080	80x92x12/7	80x90x12	80x85x15-(3)	80x95x6	122x4-(2)
60	TKR130 085	142	130	86	15	12	68	10	KTKR130 085	85x97x12/7	85x95x12	85x90x15-(3)	85x100x6	122x4-(2)
61	TKR130 090	142	130	91	15	12	68	10	KTKR130 090	90x102x12/7	90x100x12	90x95x15-(3)	90x105x6	122x4-(2)
62	TKR130 095	142	130	96	15	12	68	10	KTKR130 095	95x107x12/7	95x105x12	95x105x15-(3)	95x110x6	122x4-(2)
63	TKR130 100	142	130	101	15	12	68	10	KTKR130 100	100x112x12/7	100x120x12	100x105x15-(3)	100x115x6	122x4-(2)
64	TKR140 060	153	140	61	15	12	68	10	KTKR140 060	60x70x7/5	60x70x10	60x65x15-(3)	60x75x6	132x4-(2)
65	TKR140 070	153	140	71	15	12	68	10	KTKR140 070	70x80x7/5	70x80x12	70x75x15-(3)	70x85x6	132x4-(2)
66	TKR140 080	153	140	81	15	12	68	10	KTKR140 080	80x92x12/7	80x90x12	80x85x15-(3)	80x95x6	132x4-(2)
67	TKR140 085	153	140	86	15	12	68	10	KTKR140 085	85x97x12/7	85x95x12	85x90x15-(3)	85x100x6	132x4-(2)
68	TKR140 090	153	140	91	15	12	68	10	KTKR140 090	90x102x12/7	90x100x12	90x95x15-(3)	90x105x6	132x4-(2)
69	TKR140 095	153	140	96	15	12	68	10	KTKR140 095	95x107x12/7	95x105x12	95x100x15-(3)	95x110x6	132x4-(2)
70	TKR140 100	153	140	101	15	12	68	10	KTKR140 100	100x112x12/7	100x120x12	100x105x15-(3)	100x115x6	132x4-(2)
71	TKR140 110	153	140	111	15	12	68	10	KTKR140 110	110x122x12/7	110x125x12	110x115x15-(3)	110x125x6	132x4-(2)
72	TKR150 090	163	150	91	15	12	68	10	KTKR150 090	90x102x12/7	90x100x12	90x95x15-(3)	90x105x6	140x4-(2)
73	TKR150 100	163	150	101	15	12	68	10	KTKR150 100	100x112x12/7	100x120x12	100x105x15-(3)	100x115x6	140x4-(2)
74	TKR150 110	163	150	111	15	12	68	10	KTKR150 110	110x122x12/7	110x125x12	110x115x15-(3)	110x125x6	140x4-(2)
75	TKR150 120	163	150	121	15	12	68	10	KTKR150 120	120x132x12/7	120x140x14,6	120x125x15-(3)	120x135x6	140x4-(2)
76	TKR160 100	173	160	101	15	12	68	10	KTKR160 100	100x112x12/7	100x120x12	100x105x15-(3)	100x115x6	150x4-(2)
77	TKR160 120	173	160	121	15	12	68	10	KTKR160 120	120x132x12/7	120x140x14,6	120x125x15-(3)	120x135x6	150x4-(2)
78	TKR160 125	173	160	126	15	12	68	10	KTKR160 125	125x137x12/7	125x145x12	120x125x15-(3)	125x140x6	150x4-(2)
79	TKR160 130	173	160	131	15	12	68	10	KTKR160 130	130x142x12/7	130x150x15	130x135x15-(3)	130x145x6	150x4-(2)
80	TKR180 140	193	180	141	15	20	65	10	KTKR180 140	140x152x12/7	140x160x15	140x145x15-(3)	140x155x6	170x4-(2)

TÜM İMALATLARIMIZ KASTAŞ KEÇE TOLERANSLARINA UYGUNDUR.

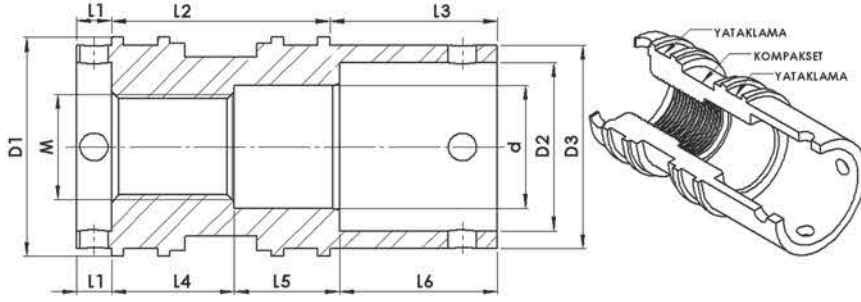

S.N	ÜRÜN KODU	D1	D2	D3	d	M	L1	L2	L3	L4	L5	L6	KEÇE KODU	KOMPAKSET	YATAKLAMA	O-RİNG
1	PR01 050	50	40	47	25	M.22x2	10	55	40	30	25	40	KPR01 050	50x38x20.5x4.2	45x50x9,5(1)	20x3
2	PR01 063	63	48	58	35	M.30x2	10	62,2	47,8	35	30	45	KPR01 063	63x051x20.5x4.2	63x58x9,5x(2)	27x4
3	PR01 070	70	55	65	40	M.35x2	10	60	50	35	30	45	KPR01 070	70x054x20.5x3.1	65x70x9,5x(2)	32x4
4	PR01 075	75	60	70	40	M.35x2	10	68,4	41,6	35	30	45	KPR01 075	75x55x22.4x6.35	70x75x9,5x(2)	32x4
5	PR01 080	80	65	75	40	M.35x2	10	70	40	35	30	45	KPR01 080	80x66x22.4x5.2	75x80x9,5x(2)	32x4
6	PR01 090	90	70	85	45	M.40x2	10	66,1	43,9	35	30	45	KPR01 090	90x076x22.4x5.2	85x90x9,5x(2)	37x4
7	PR01 100	100	80	95	50	M.45x2	10	74,2	35,8	35	30	45	KPR01 100	100x086x22.4x5.2	94x100x12,5x(2)	42x4
8	PR01 110	110	90	105	55	M.50x2	10	74,2	35,8	35	30	45	KPR01 110	110x096x22.4x5.2	104x110x12,5x(2)	47x4
9	PR01 115	115	95	110	55	M.50x2	10	74,2	35,8	35	30	45	KPR01 115	115x101x22.4x5.2	109x115x12,5x(2)	47x4
10	PR01 120	120	100	115	55	M.50x2	10	74,2	35,8	35	30	45	KPR01 120	120x106x22.4x5.2	114x120x12,5x(2)	47x4
11	PR01 125	125	105	120	55	M.50x2	10	78,1	31,9	35	30	45	KPR01 125	125x103x26.5x5.1	119x125x12,5x(2)	47x4
12	PR01 130	130	105	120	65	M.60x2	10	79,5	30,5	35	30	45	KPR01 130	130x105x25.4x6.35	124x130x12,5x(2)	57x4
13	PR01 140	140	115	130	75	M.70x2	10	82,3	27,7	35	30	45	KPR01 140	140x123x26.5x7.2	134x140x12,5x(2)	67x4
14	PR01 150	150	125	140	75	M.70x2	10	82,4	27,6	35	30	45	KPR01 150	150x125x25.4x6.35	144x150x12,5x(2)	67x4
15	PR01 160	160	135	150	80	M.70x2	10	76,3	33,7	35	30	45	KPR01 160	160x143x26.5x7.2	155x160x9,5x(2)	72x4

TÜM İMALATLARIMIZ KASTAŞ KEÇE TOLERANSLARINA UYGUNDUR.

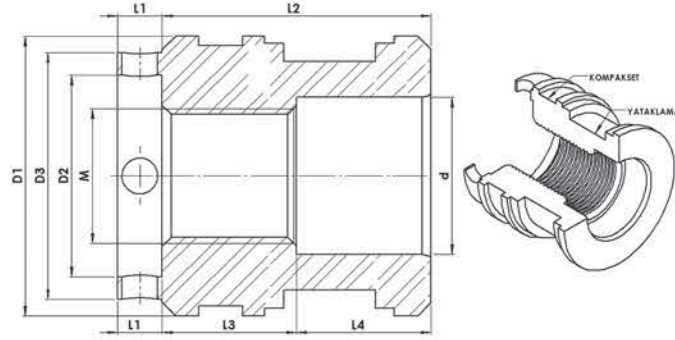

S.N	ÜRÜN KODU	D1	D2	D3	d	M	L1	L2	L3	L4	KEÇE KODU	KOMPAKSET	YATAKLAMA	O-RİNG
1	PVY050	50	30	40	25	M.22x1.5	10	55	30	25	KPVY050	50x38x20.5x4.2	50x45x9.5	20x3
2	PVY063	63	45	55	35	M.30x2	10	60	30	30	KPVY063	63x051x20.5x4.2	63x58x9.5	27x4
3	PVY070	70	55	65	40	M.35x2	10	60	30	30	KPVY070	70x054x20.5x3.1	65x70x9.5	32x4
4	PVY075	75	60	70	40	M.35x2	10	60	30	30	KPVY075	75x55x22.4x6.35	70x75x9.5	32x4
5	PVY080	80	65	75	40	M.35x2	10	60	30	30	KPVY080	80x66x22.4x5.2	75x80x9.5	32x4
6	PVY090	90	70	85	45	M.40x2	10	60	30	30	KPVY090	90x076x22.4x5.2	85x90x9.5	37x4
7	PVY100	100	80	95	50	M.45x2	10	65	30	30	KPVY100	100x086x22.4x5.2	94x100x12.5	42x4
8	PVY110	110	90	105	55	M.50x2	10	65	35	30	KPVY110	110x096x22.4x5.2	104x110x12.5	47x4
9	PVY115	115	95	110	55	M.50x2	10	65	35	30	KPVY115	115x101x22.4x5.2	109x115x12.5	47x4
10	PVY120	120	100	115	55	M.50x2	10	65	35	30	KPVY120	120x106x22.4x5.2	114x120x12.5	47x4
11	PVY125	125	105	120	55	M.50x2	10	65	35	30	KPVY125	125x103x26.5x5.1	119x125x12.5	47x4
12	PVY130	130	105	120	65	M.60x2	10	65	35	30	KPVY130	130x105x25.4x6.35	124x130x12.5	57x4
13	PVY140	140	115	130	75	M.70x2	10	70	35	35	KPVY140	140x123x26.5x7.2	134x140x12.5	67x4
14	PVY150	150	125	140	75	M.70x2	10	70	35	35	KPVY150	150x125x25.4x6.35	144x150x12.5	67x4
15	PVY160	160	135	150	80	M.70x2	10	70	35	35	KPVY160	160x143x26.5x7.2	155x160x9.5	72x4

TÜM İMALATLARIMIZ KASTAŞ KEÇE TOLERANSLARINA UYGUNDUR.

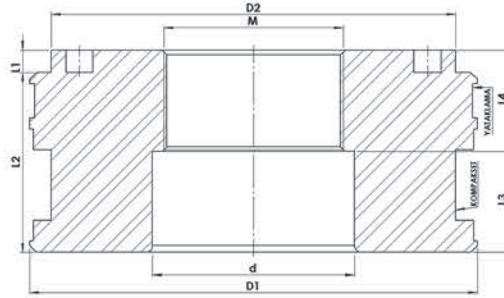

S.N	ÜRÜN KODU	D1	D2	d	M	L1	L2	L3	L4	KEÇE KODU	KOMPAKSET	YATAKLAMA	O-RİNG
1	PVY160 01	160	145	80	M.70x2	10	70	35	35	KPVY160 01	160x143x26.5x7.2	155x160x9.5	72x4
2	PVY180	180	160	80	M.70x2	5,1	64,9	35	35	KPVY180	180x163x26.5x7.2	180x175x9.5	72x4
3	PVY200	200	180	90	M.080x2	5,1	64,9	35	35	KPVY200	200x180x31,5	200x195x15	82x4
4	PVY220	220	200	90	M.080x2	9,9	80,1	45	45	KPVY220	220x200x31,5	220x215x15	82x4
5	PVY230	230	210	100	M.090x2	9,9	80,1	45	45	KPVY230	230x205x25,4x12,7	230x225x15	92x4
6	PVY250	250	230	100	M.090x2	9,9	80,1	45	45	KPVY250	250x225x25x4	250x245x15	92x4

TÜM İMALATLARIMIZ KASTAŞ KEÇE TOLERANSLARINA UYGUNDUR.

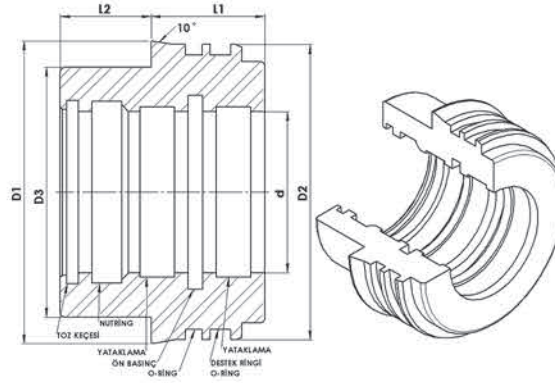

S.N	ÜRÜN KODU	D1	D2	D3	d	L1	L2	KEÇE KODU	TOZ KEÇESİ	NUTRİNG	YATAKLAMA	ÖN BASINÇ	O RİNG	DESTEK RİNGİ
1	KKB130 070	136	130	110	71	50	40	KKKB130 070	70x80x7/5	70x80x12	70x75x15-(2)	70x85x6	189,30x5,70-(2)	120,7x130x1,70
2	KKB130 080	136	130	110	81	50	40	KKKB130 080	80x92x12/7	80x90x12	80x85x15-(2)	80x95x6	189,30x5,70-(2)	120,7x130x1,70
3	KKB130 085	136	130	110	86	50	40	KKKB130 085	85x97x12/7	85x95x12	85x90x15-(2)	85x100x6	189,30x5,70-(2)	120,7x130x1,70
4	KKB130 090	136	130	110	91	50	40	KKKB130 090	90x102x12/7	90x100x12	90x95x15-(2)	90x105x6	189,30x5,70-(2)	120,7x130x1,70
5	KKB140 080	146	140	115	81	50	40	KKKB140 080	80x92x12/7	80x90x12	80x85x15-(2)	80x95x6	129,30x5,70-(2)	130,7x140x1,90
6	KKB140 085	146	140	115	86	50	40	KKKB140 085	85x97x12/7	85x95x12	85x90x15-(2)	85x100x6	129,70x5,30-(2)	130,7x140x1,90
7	KKB140 090	146	140	115	91	50	40	KKKB140 090	90x102x12/7	90x100x12	90x95x15-(2)	90x105x6	129,30x5,70-(2)	130,7x140x1,90
8	KKB140 100	146	140	115	101	50	40	KKKB140 100	100x112x12/7	100x120x12	100x105x15-(2)	100x115x6	129,70x5,30-(2)	130,7x140x1,90
9	KKB150 080	156	150	125	81	50	40	KKKB150 080	80x92x12/7	80x90x12	80x85x15-(2)	80x95x6	139,30x5,70-(2)	140x150x1,70
10	KKB150 085	156	150	125	86	50	40	KKKB150 085	85x97x12/7	85x95x12	85x90x15-(2)	85x100x6	139,30x5,70-(2)	140x150x1,70
11	KKB150 090	156	150	125	91	50	40	KKKB150 090	90x102x12/7	90x100x12	90x95x15-(2)	90x105x6	139,30x5,70-(2)	140x150x1,70
12	KKB150 100	156	150	125	101	50	40	KKKB150 100	100x112x12/7	100x120x12	100x105x15-(2)	100x115x6	139,30x5,70-(2)	140x150x1,70
13	KKB160 080	166	160	135	81	50	40	KKKB160 080	80x92x12/7	80x90x12	80x85x15-(2)	80x95x6	149,20x5,7-(2)	150,70x160x1,90
14	KKB160 085	166	160	135	86	50	40	KKKB160 085	85x97x12/7	85x95x12	85x90x15-(2)	85x100x6	149,20x5,7-(2)	150,70x160x1,90
15	KKB160 090	166	160	135	91	50	40	KKKB160 090	90x102x12/7	90x100x12	90x95x15-(2)	90x105x6	149,20x5,7-(2)	150,70x160x1,90
16	KKB160 095	166	160	135	96	50	40	KKKB160 095	95x107x12/7	95x105x12	95x100x15-(2)	95x110,5x6	149,20x5,7-(2)	150,70x160x1,90
17	KKB160 100	166	160	135	101	50	40	KKKB160 100	100x112x12/7	100x120x12	100x105x15-(2)	100x115x6	149,20x5,7-(2)	150,70x160x1,90
18	KKB160 110	166	160	135	111	50	40	KKKB160 110	110x122x12/7	110x125x12	110x115x15-(2)	110x125x6	149,20x5,7-(2)	150,70x160x1,90
19	KKB160 120	166	160	135	121	50	40	KKKB160 120	120x132x12/7	120x140x14,6	120x125x15-(2)	120x135x6	149,20x5,7-(2)	150,70x160x1,90
20	KKB180 090	186	180	155	91	50	40	KKKB180 090	90x102x12/7	90x100x12	90x95x15-(2)	90x105x6	169,30x5,7-(2)	170,70x180x1,90
21	KKB180 095	186	180	155	96	50	40	KKKB180 095	95x107x12/7	95x105x12	95x100x15-(2)	95x110x6	169,30x5,7-(2)	170,70x180x1,90
22	KKB180 100	186	180	155	101	50	40	KKKB180 100	100x112x12/7	100x120x12	100x105x15-(2)	100x115x6	169,30x5,7-(2)	170,70x180x1,90
23	KKB180 105	186	180	155	106	50	40	KKKB180 105	105x117x12/7	105x115x12	105x110x15-(2)	105x120x6	169,30x5,7-(2)	170,70x180x1,90
24	KKB180 110	186	180	155	111	50	40	KKKB180 110	110x122x12/7	110x125x12	110x115x15-(2)	110x125x6	169,30x5,7-(2)	170,70x180x1,90
25	KKB180 115	186	180	155	116	50	40	KKKB180 115	115x127x12/7	115x125x12	115x120x15-(2)	115x130x6	169,30x5,7-(2)	170,70x180x1,90
26	KKB180 120	186	180	155	121	50	40	KKKB180 120	120x132x12/7	120x140x14,6	120x125x15-(2)	120x135x6	169,30x5,7-(2)	170,70x180x1,90

TÜM İMALATLARIMIZ KASTAŞ KEÇE TOLERANSLARINA UYGUNDUR.

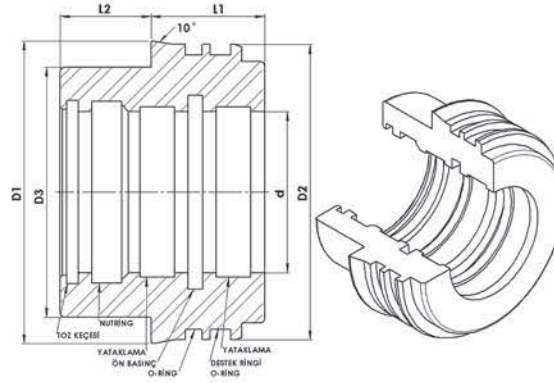

S.N	ÜRÜN KODU	D1	D2	D3	d	L1	L2	KEÇE KODU	TOZ KEÇESİ	NUTRİNG	YATAKLAMA	ÖN BASINÇ	O-RİNG	DESTEK RİNGİ
27	KKB200 090	209	200	170	91	60	40	KKKB200 090	90x102x12/7	90x100x12	90x95x15-(2)	90x105x6	189,3x5,7-(2)	190,70x200x1,90
28	KKB200 100	206	200	170	101	60	40	KKKB200 100	100x112x12/7	100x120x12	100x105x15-(2)	100x115x6	189,3x5,7-(2)	190,70x200x1,90
29	KKB200 110	206	200	170	111	60	40	KKKB200 110	110x122x12/7	110x125x12	110x115x15-(2)	110x125x6	189,3x5,7-(2)	190,70x200x1,90
30	KKB200 120	206	200	170	121	60	40	KKKB200 120	120x132x12/7	120x140x14,6	120x125x15-(2)	120x135x6	189,3x5,7-(2)	190,70x200x1,90
31	KKB200 130	206	200	170	131	60	40	KKKB200 130	130x142x12/7	130x150x15	130x135x15-(2)	130x145x6	189,3x5,7-(2)	190,70x200x1,90
32	KKB200 140	206	200	170	141	60	40	KKKB200 140	140x152x12/7	140x160x15	140x145x15-(2)	140x155,5x6	189,3x5,7-(2)	190,70x200x1,90
33	KKB220 100	206	220	185	101	60	40	KKKB220 100	100x112x12/7	100x120x12	100x105x15-(2)	100x115x6	209,20x5,7-(2)	210,70x220x1,90
34	KKB220 110	226	220	185	111	60	40	KKKB220 110	110x122x12/7	110x125x12	110x115x15-(2)	110x125x6	209,20x5,7-(2)	210,70x220x1,90
35	KKB220 120	226	220	185	121	60	40	KKKB220 120	120x132x12/7	120x140x14,6	120x125x15-(2)	120x135x6	209,20x5,7-(2)	210,70x220x1,90
36	KKB220 125	226	220	185	126	60	40	KKKB220 125	125x137x12/7	125x145x12	125x130x15-(2)	125x140x6	209,20x5,7-(2)	210,70x220x1,90
37	KKB220 150	226	220	185	151	60	40	KKKB220 150	150x162x12/7	150x170x14	150x155x15-(2)	150x165x6	209,20x5,7-(2)	210,70x220x1,90
38	KKB230 110	236	230	195	111	60	40	KKKB230 110	110x122x12/7	110x125x12	110x115x15-(2)	110x125x6	219,20x5,7-(2)	220,70x230x1,90
39	KKB230 120	236	230	195	121	60	40	KKKB230 120	120x132x12/7	120x140x14,6	120x125x15-(2)	120x135x6	219,20x5,7-(2)	220,70x230x1,90
40	KKB230 125	236	230	195	126	60	40	KKKB230 125	125x137x12/7	125x145x12	125x130x15-(2)	125x140x6	219,20x5,7-(2)	220,70x230x1,90
41	KKB230 130	236	230	195	131	60	40	KKKB230 130	130x142x12/7	130x150x15	130x135x15-(2)	130x145x6	219,20x5,7-(2)	220,70x230x1,90
42	KKB230 140	236	230	195	141	60	40	KKKB230 140	140x152x12/7	140x160x15	140x145x15-(2)	140x155x6	219,20x5,7-(2)	220,70x230x1,90
43	KKB230 150	236	230	195	151	60	40	KKKB230 150	150x162x12/7	150x170x14	150x155x15-(2)	150x165x6	219,20x5,7-(2)	220,70x230x1,90
44	KKB250 110	236	250	215	111	60	40	KKKB250 110	110x122x12/7	110x125x12	110x115x15-(2)	110x125x6	239,20x5,7-(2)	240,70x250x1,90
45	KKB250 120	256	250	215	121	60	40	KKKB250 120	120x132x12/7	120x140x14,6	120x125x15-(2)	120x135x6	239,20x5,7-(2)	240,70x250x1,90
46	KKB250 125	256	250	215	126	60	40	KKKB250 125	125x137x12/7	125x145x12	125x130x15-(2)	125x140x6	239,20x5,7-(2)	240,70x250x1,90
47	KKB250 130	256	250	215	131	60	40	KKKB250 130	130x142x12/7	130x150x15	130x135x15-(2)	130x145x6	239,20x5,7-(2)	240,70x250x1,90
48	KKB250 140	256	250	215	141	60	40	KKKB250 140	140x152x12/7	140x160x15	140x145x15-(2)	140x155,5x6	239,20x5,7-(2)	240,70x250x1,90
49	KKB250 150	256	250	215	151	60	40	KKKB250 150	150x162x12/7	150x170x14	150x155x15-(2)	150x165x6	239,20x5,7-(2)	240,70x250x1,90
50	KKB250 160	256	250	215	161	60	40	KKKB250 160	160x172x12/7	160x180x15	160x165x15-(2)	yok	239,20x5,7-(2)	240,70x250x1,90

TÜM İMALATLARIMIZ KASTAŞ KEÇE TOLERANSLARINA UYGUNDUR.

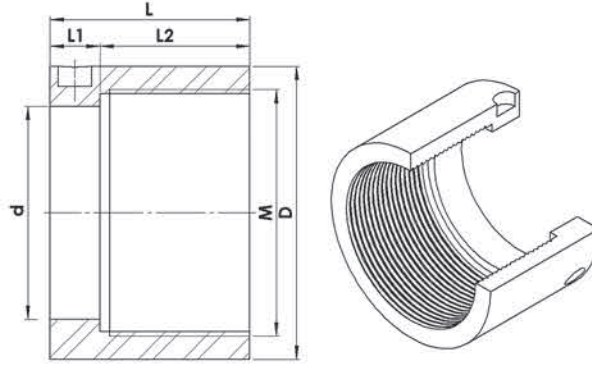

S.N	ÜRÜN KODU	D	d	M	L	L1	L2
1	BS050 060	73	51	M.59x2	50	12	38
2	BS050 065	78	51	M.69x2	50	12	38
3	BS063 075	88	64	M.74x2	60	15	45
4	BS070 080	98	71	M.79x2	60	15	45
5	BS070 085	98	71	M.84x2	60	15	45
6	BS075 090	103	76	M.89x2	60	15	45
7	BS080 095	108	81	M.94x2	60	15	45
8	BS080 100	113	81	M.99x2	60	15	45
9	BS090 105	118	91	M.104x2	60	15	45
10	BS090 110	123	91	M.109x2	60	15	45
11	BS100 115	128	101	M.114x2	60	15	45
12	BS100 120	138	101	M.118x2	60	15	45
13	BS100 125	143	101	M.124x2	60	15	45
14	BS110 130	143	111	M.129x2	60	15	45
15	BS115 130	143	116	M.129x2	60	15	45
16	BS115 135	148	116	M.134x2	60	15	45
17	BS120 140	158	121	M.139x2	60	15	45
18	BS120 145	168	121	M.144x2	60	15	45
19	BS125 145	168	126	M.144x2	60	15	45
20	BS125 150	168	126	M.149x2	60	15	45
21	BS130 150	168	131	M.149x2	60	15	45
22	BS130 155	175	131	M.154x2	60	15	45
23	BS140 160	190	141	M.159x2	60	15	45
24	BS140 165	193	141	M.164x2	60	15	45
25	BS150 170	201	151	M.169x2	60	15	45
26	BS150 180	198	151	M.179x2	60	15	45
27	BS160 180	198	161	M.179x2	60	15	45
28	BS160 185	209	161	M.184x2	60	15	45
29	BS160 190	220	161	M.189x2	60	15	45
30	BS180 210	234	181	M.209x2	70	15	55

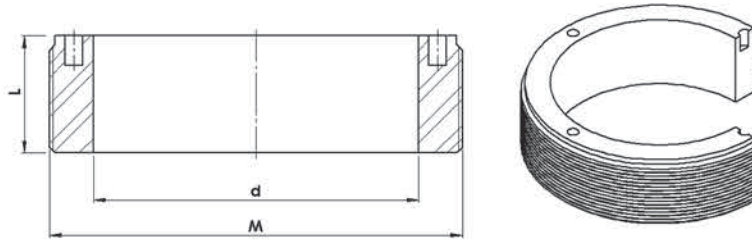

S.N	ÜRÜN KODU	M	d	L
1	KKBS130	M.141x3	111	40
2	KKBS140	M.151x3	116	40
2	KKBS150	M.161x3	126	40
3	KKBS160	M.171x3	136	40
5	KKBS180	M.191x3	156	40
6	KKBS200	M.211x3	171	40
8	KKBS220	M.231x3	186	40
9	KKBS230	M.241x3	196	40
10	KKBS250	M.261x3	216	40

PNOMATİK KLİPSLİ ÇATAL BAĞLANTI
PNEUMATIC CLIPS FORK CONNECTION

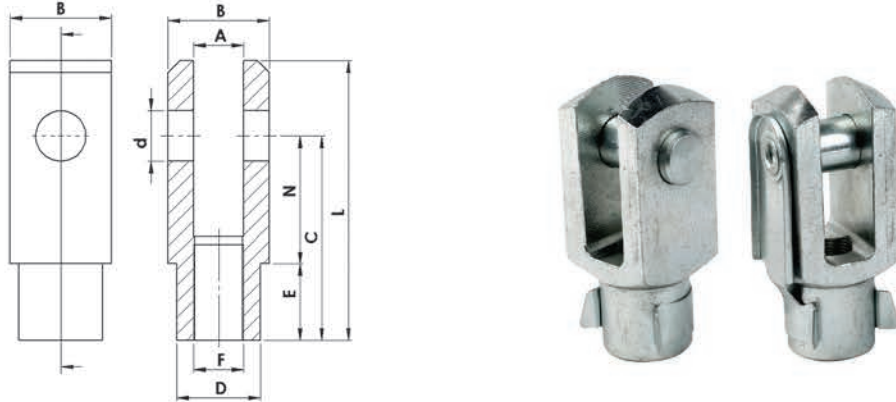

S.N	ÜRÜN KODU	BORU	F	A	B	C	E	D	d	N	L
1	ÇB M8	20	M.8x1,25	8	16	32	12	14	8	16	42
2	ÇB M10	25-32	M.10x1,25	10	20	40	14	18	10	20	52
3	ÇB M12	40	M.12x1,25	12	24	50	18	20	12	24	62
4	ÇB M16	50-63	M.16x1,5	16	30	65	24	26	16	32	83
5	ÇB M20	80-100	M.20x1,5	20	40	80	30	34	20	40	105
6	ÇB M27	125	M.27x2	27	50	100	36	44	30	54	148

HİDROLİK STANDART TEKLİ BORU KELEPÇESİ



S.N	ÜRÜN KODU	D	C	H	A	B
1	TBK 06	6	16,5	30	35	30
2	TBK 08	8	16,5	30	35	30
3	TBK 10	10	16,5	30	35	30
4	TBK 12	12	16,5	30	35	30
5	TBK 14	14	19,5	36	44	30
6	TBK 16	16	19,5	36	44	30
7	TBK 18	18	19,5	36	44	30
8	TBK 20	20	21	39	54	30
9	TBK 22	22	21	39	54	30
10	TBK 25	25	21	39	54	30
11	TBK 30	30	24	45	64	30
12	TBK 32	32	32	61	75	30
13	TBK 35	35	32	61	75	30
14	TBK 38	38	32	61	75	30
15	TBK 40	40	32	61	75	30
16	TBK 42	42	32	61	75	30

HİDROLİK STANDART İKİZ BORU KELEPÇESİ

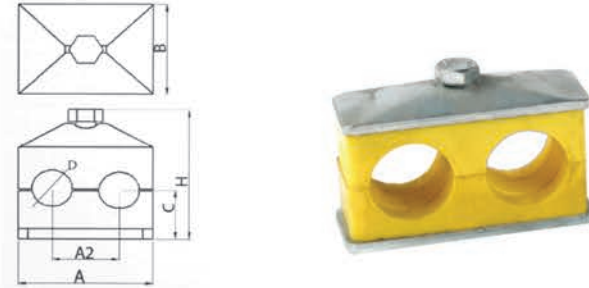

S.N	ÜRÜN KODU	D	C	H	A	A2	B
1	İBK 06	6	16,5	41	37	20	30
2	İBK 08	8	16,5	41	37	20	30
3	İBK 10	10	16,5	41	37	20	30
4	İBK 12	12	16,5	41	37	20	30
5	İBK 14	14	18,5	44,5	55	29	30
6	İBK 16	16	18,5	44,5	55	29	30
7	İBK 18	18	18,5	44,5	55	29	30
8	İBK 20	20	23,5	54,5	70	36	30
9	İBK 22	22	23,5	54,5	70	36	30
10	İBK 25	25	23,5	54,5	70	36	30
11	İBK 30	30	25,5	58,5	85	45	30

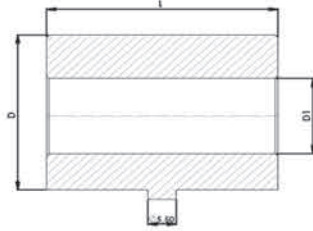

SN	ÜRÜN KODU	D1	D	L	M
1	TVLBRC-35x30	16.25	35	30	3/8
2	TVLBRC-35x60	16.25	35	60	3/8
3	TVLBRC-40x40	20.25	40	40	3/8
4	TVLBRC-40x70	20.25	40	70	3/8
5	TVLBRC-50x50	25.25	50	50	3/8
6	TVLBRC-50x50/1	30.25	50	50	3/8
7	TVLBRC-50x70	30.25	50	70	3/8
8	TVLBRC-50x80	25.25	50	80	3/8
9	TVLBRC-50x90	25.25	50	90	3/8
10	TVLBRC-60x60	30.25	60	60	3/8
11	TVLBRC-60x85	40.25	60	85	3/8
12	TVLBRC-60x100	40.25	60	100	3/8
13	TVLBRC-60x110	30.25	60	110	3/8
14	TVLBRC-70x70	40.25	70	70	3/8
15	TVLBRC-70x80	45.25	70	80	3/8
16	TVLBRC-70x100	45.25	70	100	3/8
17	TVLBRC-70x130	40.25	70	130	3/8

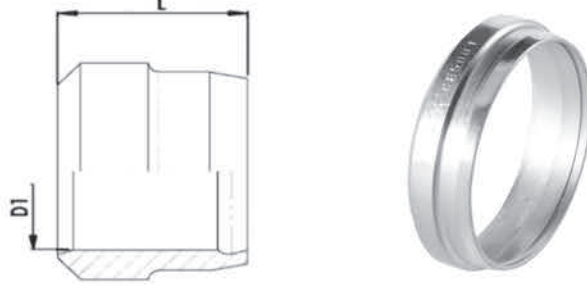

STOK KODU	DIŞ ÖLÇÜSÜ D1	L
TFYU06L	06L	9
TFYU08L	08L	9
TFYU10L	10L	9,5
TFYU12L	12L	9,5
TFYU15L	15L	9,5
TFYU18L	18L	9,5
TFYU22L	22L	10,5
TFYU28L	28L	11
TFYU35L	35L	13,5
TFYU42L	42L	13,5
s tipi		
TFYU14S	14S	9,5
TFYU16S	16S	9,5
TFYU20S	20S	12,5
TFYU25S	25S	12,5
TFYU30S	30S	12,5
TFYU38S	38S	13

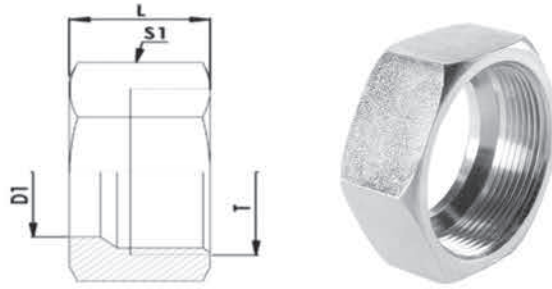

STOK KODU	Dış Ölçüsü T	D1	L	S1
TFSO06L	M12X1,5 06L	6	14,5	14
TFSO08L	M14X1,5 08L	8	14,5	17
TFSO10L	M16X1,5 10L	10	15,5	19
TFSO12L	M18X1,5 12L	12	15,5	22
TFSO15L	M22X1,5 15L	15	17	27
TFSO18L	M26X1,5 18L	18	18	32
TFSO22L	M30X2 22L	22	20	36
TFSO28L	M36X2 28L	28	21	41
TFSO35L	M45X2 35L	35	24	50
TFSO42L	M52X2 42L	42	24	60
S TİPİ				
TFSO06S	M14X1,5 06S	6	16,5	17
TFSO08S	M16X1,5 08S	8	16,5	19
TFSO10S	M18X1,5 10S	10	17,5	22
TFSO12S	M20X1,5 12S	12	17,5	24
TFSO14S	M22X1,5 14S	14	20,5	27
TFSO16S	M24X1,5 16S	16	20,5	30
TFSO20S	M30X2 20S	20	24	36
TFSO25S	M36X2 25S	25	27	46
TFSO30S	M42X2 30S	30	29	50
TFSO38S	M52X2 38S	38	32,5	60

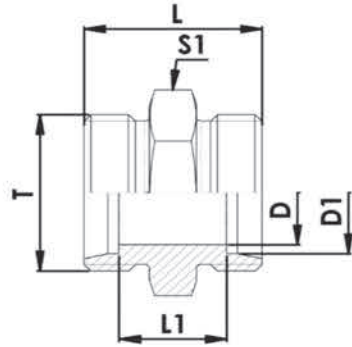

STOK KODU	DİŞ ÖLÇÜSÜ T	D	D1	L	L1	L2	S1	S2
TFGN06L	M12X1,5 06L	4	6	24	10	39	12	14
TFGN08L	M14X1,5 08L	6	8	25	11	40	14	17
TFGN10L	M16X1,5 10L	8	10	27	13	42	17	19
TFGN12L	M18X1,5 12L	10	12	28	14	43	19	22
TFGN15L	M22X1,5 15L	12	15	30	16	46	24	27
TFGN18L	M26X1,5 18L	15	18	31	16	48	27	32
TFGN22L	M30X2 22L	19	22	35	20	52	32	36
TFGN28L	M36X2 28L	24	28	36	21	54	41	41
TFGN35L	M45X2 35L	30	35	41	20	63	46	50
TFGN42L	M52X2 42L	36	42	43	21	66	55	60
S TİPİ								
TFGN06S	M14X1,5 06S	4	6	30	16	45	14	17
TFGN08S	M16X1,5 08S	5	8	32	18	47	17	19
TFGN10S	M18X1,5 10S	7	10	32	17	49	19	22
TFGN12S	M20X1,5 12S	8	12	34	19	51	22	24
TFGN14S	M22X1,5 14S	10	14	38	22	57	24	27
TFGN16S	M24X1,5 16S	12	16	38	21	57	27	30
TFGN20S	M30X2 20S	16	20	44	23	66	32	36
TFGN25S	M36X2 25S	20	25	50	26	74	41	46
TFGN30S	M42X2 30S	25	30	54	27	80	46	50
TFGN38S	M52X2 38S	32	38	61	29	90	55	60

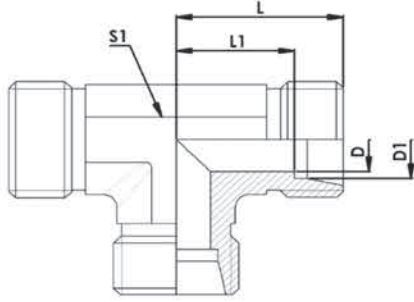

STOK KODU	DIŞ ÖLÇÜSÜ	D	D1	L	L1	L2	S1	S2
TFTE06L	M12X1,5 06L	4	6	19	12	27	12	14
TFTE08L	M14X1,5 08L	6	8	21	14	29	12	17
TFTE10L	M16X1,5 10L	8	10	22	15	30	14	19
TFTE12L	M18X1,5 12L	10	12	24	17	32	17	22
TFTE15L	M22X1,5 15L	12	15	28	21	36	19	27
TFTE18L	M26X1,5 18L	15	18	31	23,5	40	24	32
TFTE22L	M30X2 22L	19	22	35	27,5	44	27	36
TFTE28L	M36X2 28L	24	28	38	30,5	47	36	41
TFTE35L	M45X2 35L	30	35	45	34,5	56	41	50
TFTE42L	M52X2 42L	36	42	51	40	63	50	60
S TİPİ								
TFTE06S	M14X1,5 06S	4	6	23	16	31	12	17
TFTE08S	M16X1,5 08S	5	8	24	17	32	14	19
TFTE10S	M18X1,5 10S	6	10	25	17,5	34	17	22
TFTE12S	M20X1,5 12S	8	12	29	21,5	38	17	24
TFTE14S	M22X1,5 14S	10	14	30	22	40	19	27
TFTE16S	M24X1,5 16S	12	16	33	24,5	43	24	30
TFTE20S	M30X2 20S	16	20	37	26,5	48	27	36
TFTE25S	M36X2 25S	20	25	42	30	54	36	46
TFTE30S	M42X2 30S	25	30	49	35,5	62	41	50
TFTE38S	M52X2 38S	32	38	57	41	72	50	60

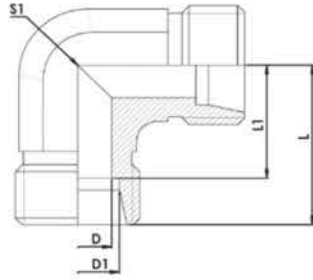

STOK KODU	DIŞ ÖLÇÜSÜ	D	D1	L	L1	L3	S1	S2
TFDI06L	M12X1,5 06L	4	6	19	12	27	12	14
TFDI08L	M14X1,5 08L	6	8	21	14	29	12	17
TFDI10L	M16X1,5 10L	8	10	22	15	30	14	19
TFDI12L	M18X1,5 12L	10	12	24	17	32	17	22
TFDI15L	M22X1,5 15L	12	15	28	21	36	19	27
TFDI18L	M26X1,5 18L	15	18	31	23,5	40	24	32
TFDI22L	M30X2 22L	19	22	35	27,5	44	27	36
TFDI28L	M36X2 28L	24	28	38	30,5	47	36	41
TFDI35L	M45X2 35L	30	35	45	34,5	56	41	50
TFDI42L	M52X2 42L	36	52	51	40	63	50	60
S TİPİ								
TFDI06S	M14X1,5 06S	4	6	23	16	31	12	17
TFDI08S	M16X1,5 08S	5	8	24	17	32	14	19
TFDI10S	M18X1,5 10S	7	10	25	17,5	34	17	22
TFDI12S	M20X1,5 12S	8	12	29	21,5	38	17	24
TFDI14S	M22X1,5 14S	10	14	30	22	40	19	27
TFDI16S	M24X1,5 16S	12	16	33	24,5	43	24	30
TFDI20S	M30X2 20S	16	20	37	26,5	48	27	36
TFDI25S	M36X2 25S	20	25	42	30	54	36	46
TFDI30S	M42X2 30S	25	30	49	35,5	62	41	50
TFDI38S	M52X2 38S	32	38	57	41	72	50	60

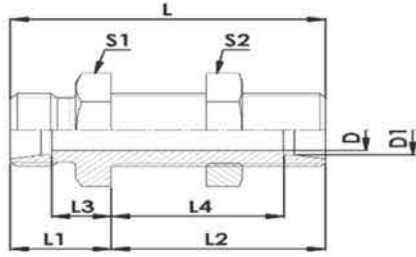

STOK KODU	DIŞ ÖLÇÜSÜ	D	D1	L	L1	L2	L3	L4	L5	L6	S1	S2	S3
TFGP06L	M12X1,5 06L	4	6	48	14	34	7	27	22	42	17	17	14
TFGP08L	M14X1,5 08L	6	8	49	15	34	8	27	23	42	19	19	17
TFGP10L	M16X1,5 10L	8	10	52	17	35	10	28	25	43	22	22	19
TFGP12L	M18X1,5 12L	10	12	53	17	36	10	29	25	44	24	24	22
TFGP15L	M22X1,5 15L	12	15	57	19	38	12	31	27	46	27	30	27
TFGP18L	M26X1,5 18L	15	18	61	21	40	13,5	32,5	30	49	32	36	32
TFGP22L	M30X2 22L	19	22	66	24	42	16,5	34,5	33	51	36	41	36
TFGP28L	M36X2 28L	24	28	69	26	43	18,5	35,5	35	52	41	46	41
TFGP35L	M45X2 35L	30	35	76	29	47	18,5	36,5	40	58	50	55	50
TFGP42L	M52X2 42L	36	42	77	30	47	19	36	42	59	60	65	60
S TİPİ													
TFGP06S	M14X1,5 06S	4	6	55	19	36	12	29	27	44	19	19	17
TFGP08S	M16X1,5 08S	5	8	56	20	36	13	29	28	44	22	22	19
TFGP10S	M18X1,5 10S	7	10	59	22	37	14,5	29,5	31	46	24	24	22
TFGP12S	M20X1,5 12S	8	12	60	22	38	14,5	30,5	31	47	27	27	24
TFGP14S	M22X1,5 14S	10	14	65	25	40	17	32	35	50	30	30	27
TFGP16S	M24X1,5 16S	12	16	65	25	40	16,5	31,5	35	50	32	32	30
TFGP20S	M30X2 20S	16	20	72	28	44	17,5	33,5	39	55	41	41	36
TFGP25S	M36X2 25S	20	25	79	32	47	20	35	44	59	46	46	46
TFGP30S	M42X2 30S	25	30	86	35	51	21,5	37,5	48	64	50	50	50
TFGP38S	M52X2 38S	32	38	91	38	53	22	37	53	68	65	60	60

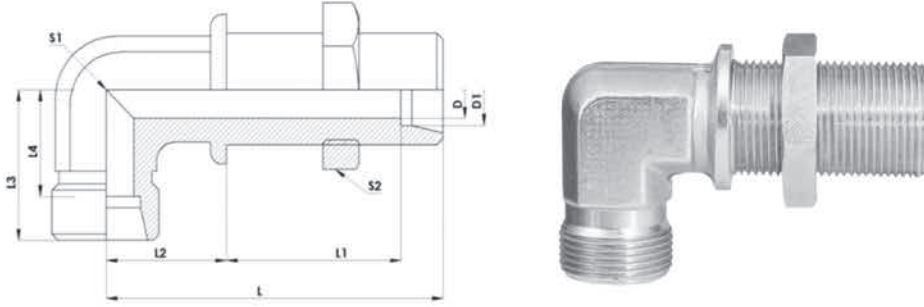

STOK KODU	DİŞ ÖLÇÜSÜ	D	D1	L	L1	L2	L3	L4	L5	L6	S1	S2	S3
TFPD06L	M12X1,5 06L	4	6	48	27	14	19	12	42	27	12	17	14
TFPD08L	M14X1,5 08L	6	8	51	27	17	21	14	42	29	12	19	17
TFPD10L	M16X1,5 10L	8	10	53	28	18	22	15	43	30	14	22	19
TFPD12L	M18X1,5 12L	10	12	56	29	20	24	17	44	32	17	24	22
TFPD15L	M22X1,5 15L	12	15	61	31	23	28	21	46	36	19	30	27
TFPD18L	M26X1,5 18L	15	18	64	32,5	24	31	23,5	49	40	24	36	32
TFPD22L	M30X2 22L	19	22	72	34,5	30	35	27,5	51	44	27	41	36
TFPD28L	M36X2 28L	24	28	77	35,5	34	38	30,5	52	47	36	46	41
TFPD35L	M45X2 35L	30	35	86	36,5	39	45	34,5	58	56	41	55	50
TFPD42L	M52X2 42L	36	42	90	36	43	51	40	59	63	50	65	60
S TIPI													
TFPD06S	M14X1,5 06S	4	6	53	29	17	23	16	44	31	12	19	17
TFPD08S	M16X1,5 08S	5	8	54	29	18	24	17	44	32	14	22	19
TFPD10S	M18X1,5 10S	7	10	57	29,5	20	25	17,5	46	34	17	24	22
TFPD12S	M20X1,5 12S	8	12	59	30,5	21	29	21,5	47	38	17	27	24
TFPD14S	M22X1,5 14S	10	14	63	32	23	30	22	50	40	19	30	27
TFPD16S	M24X1,5 16S	12	16	64	31,5	24	33	24,5	50	43	24	32	30
TFPD20S	M30X2 20S	16	20	74	33,5	30	37	26,5	55	48	27	41	36
TFPD25S	M36X2 25S	20	25	81	35	34	42	30	59	54	36	46	46
TFPD30S	M42X2 30S	25	30	90	37,5	39	49	35,5	64	62	41	50	50
TFPD38S	M52X2 38S	32	38	96	37	43	57	41	68	72	50	65	60

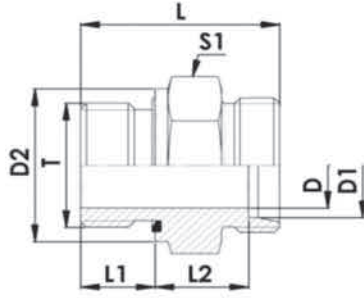

STOK KODU	Diş ölçüsü	Diş ölçüsü T	D	D1	D2	L	L1	L2	L3	S1	S2
TFGER1006LP	M12X1,5 06L	1/8-28	4	6	14	23,5	8	8,5	23	14	14
TFGER1306LP	M12X1,5 06L	1/4-19	4	6	19	29	12	10	25	19	14
TFGER1706LP	M12X1,5 06L	3/8-19	4	6	22	30,5	12	11,5	26	22	14
TFGER2106LP	M12X1,5 06L	1/2-14	4	6	27	33	14	12	27	27	14
TFGER1008LP	M14X1,5 08L	1/8-28	4	8	14	24,5	8	9,5	24	14	17
TFGER1308LP	M14X1,5 08L	1/4-19	6	8	19	29	12	10	25	19	17
TFGER1708LP	M14X1,5 08L	3/8-19	6	8	22	30,5	12	11,5	26	22	17
TFGER2108LP	M14X1,5 08L	1/2-14	6	8	27	33	14	12	27	27	17
TFGER1010LP	M16X1,5 10L	1/8-28	4	10	14	25,5	8	10,5	25	17	19
TFGER1310LP	M16X1,5 10L	1/4-19	6	10	19	30	12	11	26	19	19
TFGER1710LP	M16X1,5 10L	3/8-19	8	10	22	31,5	12	12,5	27	22	19
TFGER2110LP	M16X1,5 10L	1/2-14	8	10	27	34	14	13	28	27	19
TFGER1312LP	M18X1,5 12L	1/4-19	6	12	19	31	12	12	27	19	22
TFGER1712LP	M18X1,5 12L	3/8-19	9	12	22	31,5	12	12,5	27	22	22
TFGER2112LP	M18X1,5 12L	1/2-14	10	12	27	34	14	13	28	27	22
TFGER2612LP	M18X1,5 12L	3/4-14	10	12	32	37	16	14	29	32	22
TFGER1715LP	M22X1,5 15L	3/8-19	9	15	22	32,5	12	13,5	29	24	27
TFGER2115LP	M22X1,5 15L	1/2-14	12	15	27	35	14	14	29	27	27
TFGER2615LP	M22X1,5 15L	3/4-14	12	15	32	38	16	15	30	32	27
TFGER2118LP	M26X1,5 18L	1/2-14	14	18	27	36	14	14,5	31	27	32
TFGER2618LP	M26X1,5 18L	3/4-14	15	18	32	38	16	14,5	31	32	32
TFGER2122LP	M30X2 22L	1/2-14	14	22	27	38	14	16,5	33	32	36
TFGER2622LP	M30X2 22L	3/4-14	18	22	32	40	16	16,5	33	32	36
TFGER3322LP	M30X2 22L	1"-11	19	22	41	43	18	17,5	34	41	36
TFGER2628LP	M36X2 28L	3/4-14	18	28	32	41	16	17,5	34	41	41
TFGER3328LP	M36X2 28L	1"-11	23	28	41	43	18	17,5	34	41	41
TFGER4228LP	M36X2 28L	1" 1/4-11	24	28	50	46	20	17,5	35	50	41
TFGER3335LP	M45X2 35L	1"-11	23	35	41	46	18	18,5	39	46	50
TFGER4235LP	M45X2 35L	1" 1/4-11	30	35	50	48	20	19	39	50	50
TFGER4835LP	M45X2 35L	1" 1/2-11	30	35	55	52	22	19	41	55	50
TFGER4242LP	M52X2 42L	1" 1/4-11	30	42	50	50	20	19,5	42	55	60
TFGER4842LP	M52X2 42L	1" 1/2-11	36	42	55	52	22	19	42	55	60

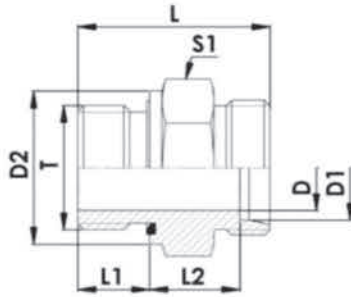

STOK KODU	DIŞ ÖLÇÜSÜ	DIŞ ÖLÇÜSÜ T	D	D1	D2	L	L1	L2	L3	S1	S2
TFGER1006SP	M14X1,5 06S	1/8-28	4	6	14	27,5	8	12,5	27	14	17
TFGER1306SP	M14X1,5 06S	1/4-19	5	6	19	32	12	13	28	19	17
TFGER1008SP	M16X1,5 08S	1/8-28	5	8	14	27,5	8	12,5	28	17	19
TFGER1308SP	M16X1,5 08S	1/4-19	5	8	19	34	12	15	30	19	19
TFGER1708SP	M16X1,5 08S	3/8-19	7	8	22	34,5	12	15,5	30	22	19
TFGER2108SP	M16X1,5 08S	1/2-14	5	8	27	39	14	18	33	27	19
TFGER1310SP	M18X1,5 10S	1/4-19	5	10	19	34	12	14,5	31	19	22
TFGER1710SP	M18X1,5 10S	3/8-19	7	10	22	34,5	12	15	31	22	22
TFGER2110SP	M18X1,5 10S	1/2-14	7	10	27	39	14	17,5	34	27	22
TFGER1312SP	M20X1,5 12S	1/4-19	5	12	19	36	12	16,5	33	22	24
TFGER1712SP	M20X1,5 12S	3/8-19	8	12	22	36,5	12	17	33	22	24
TFGER2112SP	M20X1,5 12S	1/2-14	8	12	27	39	14	17,5	34	27	24
TFGER2612SP	M20X1,5 12S	3/4-14	8	12	32	43	16	19,5	36	32	24
TFGER3312SP	M20X1,5 12S	1"-11	8	12	41	47	18	21,5	38	41	24
TFGER2114SP	M22X1,5 14S	1/2-14	10	14	27	41	14	19	37	27	27
TFGER1716SP	M24X1,5 16S	3/8-19	8	16	22	38,5	12	18	36	27	30
TFGER2116SP	M24X1,5 16S	1/2-14	12	16	27	41	14	18,5	37	27	30
TFGER2616SP	M24X1,5 16S	3/4-14	12	16	32	45	16	20,5	39	32	30
TFGER3316SP	M24X1,5 16S	1"-11	12	16	41	49	18	22,5	41	41	30
TFGER1720SP	M30X2 20S	3/8-19	8	20	22	40,5	12	18	40	32	36
TFGER2120SP	M30X2 20S	1/2-14	12	20	27	45	14	20,5	42	32	36
TFGER2620SP	M30X2 20S	3/4-14	16	20	32	47	16	20,5	42	32	36
TFGER3320SP	M30X2 20S	1"-11	16	20	41	51	18	22,5	44	41	36
TFGER4220SP	M30X2 20S	1" 1/4-11	16	20	50	53	20	22,5	44	50	36
TFGER2125SP	M36X2 25S	1/2-14	12	25	27	49	14	23	47	41	46
TFGER2625SP	M36X2 25S	3/4-14	16	25	32	51	16	23	47	41	46
TFGER3325SP	M36X2 25S	1"-11	20	25	41	53	18	23	47	41	46
TFGER4225SP	M36X2 25S	1" 1/4-11	20	25	50	55	20	23	47	50	46
TFGER4825SP	M36X2 25S	1" 1/2-11	20	25	55	60	22	26	50	55	46
TFGER2630SP	M42X2 30S	3/4-14	17	30	32	53	16	23,5	50	46	50
TFGER3330SP	M42X2 30S	1"-11	20	30	41	55	18	23,5	50	46	50
TFGER4230SP	M42X2 30S	1" 1/4-11	25	30	50	57	20	23,5	50	50	50
TFGER4830SP	M42X2 30S	1" 1/2-11	25	30	55	62	22	26,5	53	55	50
TFGER3338SP	M52X2 38S	1"-11	22	38	41	57	18	23	54	55	60
TFGER4238SP	M52X2 38S	1" 1/4-11	25	38	50	62	20	26	57	55	60
TFGER4838SP	M52X2 38S	1" 1/2-11	32	38	55	64	22	26	57	55	60

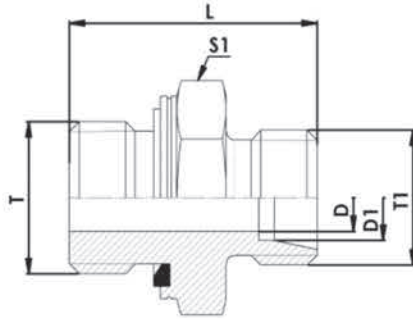

STOK KODU	DIŞ ÖLÇÜSÜ T1	D1	DIŞ ÖLÇÜSÜ T	D	L	L1	S1	S2
TFGEM10C06LP	M12X1,5	6	M10X1	4	23,5	23	14	14
TFGEM12C08LP	M14X1,5	8	M12X1,5	6	29	25	17	17
TFGEM14C10LP	M16X1,5	10	M14X1,5	7	30	26	19	19
TFGEM16C12LP	M18X1,5	12	M16X1,5	9	31,5	27	22	22
TFGEM18C15LP	M22X1,5	15	M18X1,5	11	32,5	29	24	27
TFGEM22C18LP	M26X1,5	18	M22X1,5	14	36	31	27	32
TFGEM26C22LP	M30X2	22	M26X1,5	18	40	33	32	36
TFGEM33C28LP	M36X2	28	M33X2	23	43	34	41	41
TFGEM42C35LP	M45X2	35	M42X2	30	48	39	50	50
TFGEM48C42LP	M52X2	42	M48X2	36	52	42	55	60
S TİPİ								
TFGEM12C06SP	M12X1,5	6	M12X1,5	4	32	28	17	17
TFGEM14C08SP	M16X1,5	8	M14X1,5	5	34	30	19	19
TFGEM16C10SP	M18X1,5	10	M16X1,5	7	34,5	31	22	22
TFGEM18C12SP	M20X1,5	12	M18X1,5	8	36,5	33	24	24
TFGEM20C14SP	M22X1,5	14	M20X1,5	10	41	37	27	27
TFGEM22C16SP	M24X1,5	16	M22X1,5	12	41	37	27	30
TFGEM27C20SP	M30X2	20	M27X2	16	47	42	32	36
TFGEM33C25SP	M36X2	25	M33X2	20	53	47	41	46
TFGEM42C30SP	M42X2	30	M42X2	25	57	50	50	50
TFGEM48C38SP	M52X2	38	M48X2	32	64	57	55	60

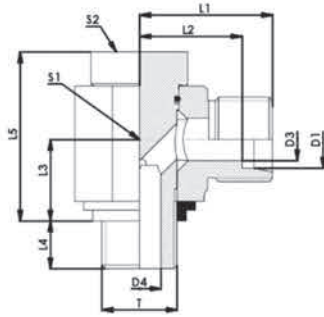

STOK KODU	T	DIŞ ÖLÇÜSÜ D1	D3	D4	L1	L2	L3	L4	L5	L6	S1	S2	S3
TFDNR1006L	1/8-28	M12X1,5 06L	4	4,5	19	12	10,5	8	24	24	17	17	14
TFDNR1308L	1/4-19	M14X1,5 08L	6	6	21,5	14,5	14	12	30	29	22	19	17
TFDNR1310L	1/4-19	M16X1,5 10L	8	6	22,5	15,5	14	12	30	30	22	19	19
TFDNR1712L	3/8-19	M18X1,5 12L	10	7,5	25	18	16,5	12	36	33	27	24	22
TFDNR2115L	1/2-14	M22X1,5 15L	12	11	28,5	21,5	21,5	14	45	37	32	30	27
TFDNR2118L	1/2-14	M26X1,5 18L	15	11	28,5	21	21,5	14	45	37	32	30	32
TFDNR2622L	3/4-14	M30X2 22L	19	17	35	27,5	24	16	53	44	41	36	36
TFDNR3328L	1"-11	M36X2 28L	24	21	39,5	32	30,5	18	66	49	50	46	41
TFDNR4235L	1"1/4-11	M45X2 35L	30	27	46,5	36	35,5	20	76	58	60	55	50
TFDNR4842L	1"1/2-11	M52X2 42L	36	34	51,5	40,5	40,5	22	87	63	70	60	60
S TİPİ													
TFDNR1306S	1/4-19	M14X1,5 06S	4	6	23,5	16,5	14	12	30	31	22	19	17
TFDNR1308S	1/4-19	M16X1,5 08S	5	6	23,5	16,5	14	12	30	31	22	19	19
TFDNR1710S	3/8-19	M18X1,5 10S	7	7,5	26	18,5	16,5	12	36	35	27	24	22
TFDNR1712S	3/8-19	M20X1,5 12S	8	7,5	26	18,5	16,5	12	36	35	27	24	24
TFDNR2116S	1/2-14	M24X1,5 16S	12	11	30,5	22	21,5	14	45	40	32	30	30
TFDNR2620S	3/4-14	M30X2 20S	16	17	37	26,5	24	16	53	48	41	36	36
TFDNR3325S	1"-11	M36X2 25S	20	21	43,5	31,5	30,5	18	66	56	50	46	46
TFDNR4230S	1"1/4-11	M42X2 30S	25	27	50,5	37	35,5	20	76	64	60	55	50
TFDNR4838S	1"1/2-11	M52X2 38S	32	34	57,5	41,5	40,5	22	87	72	70	60	60

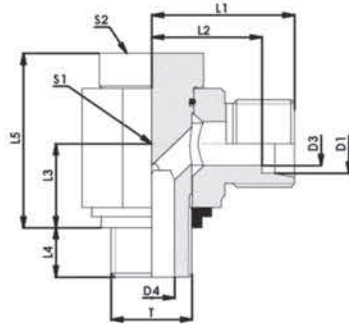

STOK KODU	T	Diş Ölçüsü D1	D3	D4	L1	L2	L3	L4	L5	L6	S1	S2	S3
TFDNM1006L	M10X1	M12X1,5 06L	4	4,5	19	12	10,5	8	24	27	17	17	14
TFDNM1208L	M12X1,5	M14X1,5 08L	6	6	21,5	14,5	14	12	30	29	22	19	17
TFDNM1410L	M14X1,5	M16X1,5 10L	8	6	22,5	15,5	14	12	30	30	22	19	19
TFDNM1612L	M16X1,5	M18X1,5 12L	10	7,5	25	18	16,5	12	36	33	27	24	22
TFDNM1815L	M18X1,5	M22X1,5 15L	11	9	27,5	21,5	18,5	12	39,5	37	30	30	27
TFDNM2218L	M22X1,5	M26X1,5 18L	15	12	28,5	21	21,5	14	45	37	32	30	32
TFDNM2622L	M26X1,5	M30X2 22L	19	17	35	27,5	24	16	53	44	41	36	36
TFDNM3328L	M33X2	M36X2 28L	24		39,5	32	30,5	18	66	49	50	46	41
TFDNM4235L	M42X2	M45X2 35L	30	27	46,5	36	35,5	20	76	58	60	55	50
TFDNM4842L	M48X2	M52X2 42L	36	34	51,5	40,5	40,5	22	87	63	70	60	60
S tipi													
TFDNM1206S	M12X1,5	M14X1,5 06S	4	6	23,5	16,5	14	12	30	31	22	19	17
TFDNM1408S	M14X1,5	M16X1,5 08S	5	6	23,5	16,5	14	12	30	31	22	19	19
TFDNM1610S	M16X1,5	M18X1,5 10S	7	7,5	26	18,5	16,5	12	36	35	27	24	22
TFDNM1812S	M18X1,5	M20X1,5 12S	8	9	27,5	20	18,5	12	39,5	36	27	27	24
TFDNM2216S	M22X1,5	M24X1,5 16S	12	12	30,5	22	21,5	14	45	40	32	30	30
TFDNM2720S	M27X2	M30X2 20S	16	16	37	26,5	24	16	53	48	41	36	36
TFDNM3325S	M33X2	M36X2 25S	20	21	43,5	31,5	30,5	18	66	56	50	46	46
TFDNM4230S	M42X2	M42X2 30S	25	27	50,5	37	35,5	20	76	64	60	55	50
TFDNM4838S	M48X2	M52X2 38S	32	34	57,5	41,5	40,5	22	87	72	70	60	60

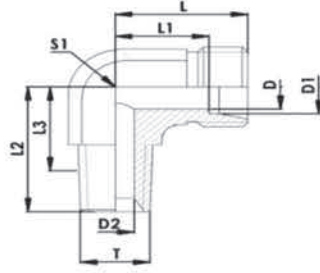

STOK KOD	DIŞ ÖLÇÜSÜ D1	DIŞ ÖLÇÜSÜ T	D	D2	L	L1	L2	L3	L4	S1	S2
TFDIN1006L	M12X1,5 06L	1/8-28 BSPT	4	4	19	12	20	14	27	12	14
TFDIN1306L	M12X1,5 06L	1/4-19 BSPT	4	7	21	14	26	17	29	12	14
TFDIN1008L	M14X1,5 08L	1/8-28 BSPT	6	4	21	14	26	20	29	12	17
TFDIN1308L	M14X1,5 08L	1/4-19 BSPT	6	6	21	14	26	17	29	12	17
TFDIN1708L	M14X1,5 08L	3/8-19 BSPT	6	8	21	14	28	19	29	17	17
TFDIN1310L	M16X1,5 10L	1/4-19 BSPT	8	7	22	15	27	18	30	14	19
TFDIN1710L	M16X1,5 10L	3/8-19 BSPT	8	8	24	17	28	19	32	17	19
TFDIN2110L	M16X1,5 10L	1/2-14 BSPT	8	11	28	21	34	22	32	19	19
TFDIN1312L	M18X1,5 12L	1/4-19 BSPT	10	7	24	17	28	19	32	17	22
TFDIN1712L	M18X1,5 12L	3/8-19 BSPT	10	8	24	17	28	19	32	17	22
TFDIN2112L	M18X1,5 12L	1/2-14 BSPT	10	11	28	21	34	22	36	19	22
TFDIN2115L	M22X1,5 15L	1/2-14 BSPT	12	11	28	21	34	22	36	19	27
TFDIN2118L	M26X1,5 18L	1/2-14 BSPT	15	12	31	23,5	36	24	40	24	32
TFDIN2622L	M30X2 22L	3/4-14 BSPT	19	16	35	27,5	42	30	44	27	36
TFDIN3328L	M36X2 28L	1"-11 BSPT	24	21	38	30,5	48	33	47	36	41
TFDIN4235L	M45X2 35L	1"1/4-11 BSPT	30	28	45	34,5	54	39	56	41	50
TFDIN4842L	M52X2 42L	1"1/2-11 BSPT	36	34	51	40	61	46	63	50	60
S TİPİ											
TFDIN1306S	M14X1,5 06S	1/4-19 BSPT	4	4	23	16	26	17	31	12	17
TFDIN1308S	M16X1,5 08S	1/4-19 BSPT	5	5	24	17	27	18	32	14	19
TFDIN1708S	M16X1,5 08S	3/8-19 BSPT	5	8	25	18	28	19	33	17	19
TFDIN1310S	M18X1,5 10S	1/4-19 BSPT	7	5	25	18	28	19	34	17	22
TFDIN1710S	M18X1,5 10S	3/8-19 BSPT	7	7	25	18	28	19	34	17	22
TFDIN1712S	M20X1,5 12S	3/8-19 BSPT	8	8	29	21,5	28	19	38	17	24
TFDIN2112S	M20X1,5 12S	1/2-14 BSPT	8	10	30	22,5	34	22	39	19	24
TFDIN2114S	M22X1,5 14S	1/2-14 BSPT	10	10	30	22	34	22	40	19	27
TFDIN1716S	M24X1,5 16S	3/8-19 BSPT	12	8	33	24,5	31	22	43	24	30
TFDIN2116S	M24X1,5 16S	1/2-14 BSPT	12	12	33	24,5	36	24	43	24	30
TFDIN2616S	M24X1,5 16S	3/4-14 BSPT	12	12	37	28,5	42	30	43	27	30
TFDIN2120S	M30X2 20S	1/2-14 BSPT	16	12	37	26,5	36	24	48	27	36
TFDIN2620S	M30X2 20S	3/4-14 BSPT	16	16	37	26,5	42	30	48	27	36
TFDIN3320S	M30X2 20S	1"-11 BSPT	16	20	42	31,5	48	33	48	36	36
TFDIN2625S	M36X2 25S	3/4-14 BSPT	20	16	42	30	42	30	54	36	46
TFDIN3325S	M36X2 25S	1"-11 BSPT	20	20	42	30	48	33	54	36	46
TFDIN3330S	M42X2 30S	1"-11 BSPT	25	20	49	35,5	48	33	62	41	50
TFDIN4230S	M42X2 30S	1"1/4-11 BSPT	25	25	49	35,5	54	39	62	41	50
TFDIN4238S	M52X2 38S	1"1/4-11 BSPT	32	25	57	41	60	45	72	50	60
TFDIN4838S	M52X2 38S	1"1/2-11 BSPT	32	32	57	41	61	46	72	50	60

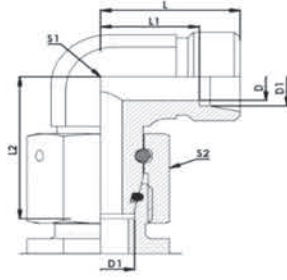

STOK KODU	DIŞ ÖLÇÜSÜ	D	D1	L	L1	L2	L3	S1	S2
TFDIT06L	M12X1,5 06L	4	6	19	12	26	27	12	14
TFDIT08L	M14X1,5 08L	6	8	21	14	27,5	29	12	17
TFDIT10L	M16X1,5 10L	8	10	22	15	29	30	14	19
TFDIT12L	M18X1,5 12L	10	12	24	17	29,5	32	17	22
TFDIT15L	M22X1,5 15L	12	15	28	21	32,5	36	19	27
TFDIT18L	M26X1,5 18L	15	18	31	23,5	35,5	40	24	32
TFDIT22L	M30X2 22L	19	22	35	27,5	38,5	44	27	36
TFDIT28L	M36X2 28L	24	28	38	30,5	41,5	47	36	41
TFDIT35L	M45X2 35L	30	35	45	34,5	51	56	41	50
TFDIT42L	M52X2 42L	36	42	51	40	56	63	50	60
S TİPİ									
TFDIT06S	M14X1,5 06S	4	6	23	16	27	31	12	17
TFDIT08S	M16X1,5 08S	5	8	24	17	27,5	32	14	19
TFDIT10S	M18X1,5 10S	6	10	25	17,5	30	34	17	22
TFDIT12S	M20X1,5 12S	8	12	29	21,5	31	38	17	24
TFDIT14S	M22X1,5 14S	9	14	30	22	35	40	19	27
TFDIT16S	M24X1,5 16S	12	16	33	24,5	36,5	43	24	30
TFDIT20S	M30X2 20S	16	20	37	26,5	44,5	48	27	36
TFDIT25S	M36X2 25S	20	25	42	30	50	54	36	46
TFDIT30S	M42X2 30S	25	30	49	35,5	55	62	41	50
TFDIT38S	M52X2 38S	32	38	57	41	63	72	50	60

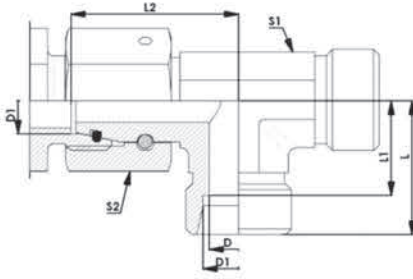

STOK KODU	DIŞ ÖLÇÜSÜ	D	D1	L	L1	L2	L3	S1	S2
TFTEF06L	M12X1,5 06L	4	6	19	12	26	27	12	14
TFTEF08L	M14X1,5 08L	6	8	21	14	27,5	29	12	17
TFTEF10L	M16X1,5 10L	8	10	22	15	29	30	14	19
TFTEF12L	M18X1,5 12L	10	12	24	17	29,5	32	17	22
TFTEF15L	M22X1,5 15L	12	15	28	21	32,5	36	19	27
TFTEF18L	M26X1,5 18L	15	18	31	23,5	35,5	40	24	32
TFTEF22L	M30X2 22L	19	22	35	27,5	38,5	44	27	36
TFTEF28L	M36X2 28L	24	28	38	30,5	41,5	47	36	41
TFTEF35L	M45X2 35L	30	35	45	34,5	51	56	41	50
TFTEF42L	M52X2 42L	36	42	51	40	56	63	50	60
S TİPİ									
TFTEF06S	M14X1,5 06S	4	6	23	16	27	31	12	17
TFTEF08S	M16X1,5 08S	5	8	24	17	27,5	32	14	19
TFTEF10S	M18X1,5 10S	6	10	25	17,5	30	34	17	22
TFTEF12S	M20X1,5 12S	8	12	29	21,5	31	38	17	24
TFTEF14S	M22X1,5 14S	9	14	30	22	35	40	19	27
TFTEF16S	M24X1,5 16S	12	16	33	24,5	36,5	43	24	30
TFTEF20S	M30X2 20S	16	20	37	26,5	44,5	48	27	36
TFTEF25S	M36X2 25S	20	25	42	30	50	54	36	46
TFTEF30S	M42X2 30S	25	30	49	35,5	55	62	41	50
TFTEF38S	M52X2 38S	32	38	57	41	63	72	50	60

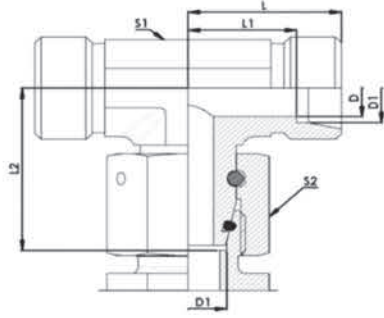

STOK KODU	DIŞ ÖLÇÜSÜ	D	D1	L	L1	L2	L3	S1	S2
TFTEG06L	M12X1,5 06L	4	6	19	12	26	27	12	14
TFTEG08L	M14X1,5 08L	6	8	21	14	27,5	29	12	17
TFTEG10L	M16X1,5 10L	8	10	22	15	29	30	14	19
TFTEG12L	M18X1,5 12L	10	12	24	17	29,5	32	17	22
TFTEG15L	M22X1,5 15L	12	15	28	21	32,5	36	19	27
TFTEG18L	M26X1,5 18L	15	18	31	23,5	35,5	40	24	32
TFTEG22L	M30X2 22L	19	22	35	27,5	38,5	44	27	36
TFTEG28L	M36X2 28L	24	28	38	30,5	41,5	47	36	41
TFTEG35L	M45X2 35L	30	35	45	34,5	51	56	41	50
TFTEG42L	M52X2 42L	36	42	51	40	56	63	50	60
S TİPİ									
TFTEG06S	M14X1,5 06S	4	6	23	16	27	31	12	17
TFTEG08S	M16X1,5 08S	5	8	24	17	27,5	32	14	19
TFTEG10S	M18X1,5 10S	6	10	25	17,5	30	34	17	22
TFTEG12S	M20X1,5 12S	8	12	29	21,5	31	38	17	24
TFTEG14S	M22X1,5 14S	9	14	30	22	35	40	19	27
TFTEG16S	M24X1,5 16S	12	16	33	24,5	36,5	43	24	30
TFTEG20S	M30X2 20S	16	20	37	26,5	44,5	48	27	36
TFTEG25S	M36X2 25S	20	25	42	30	50	54	36	46
TFTEG30S	M42X2 30S	25	30	49	35,5	55	62	41	50
TFTEG38S	M52X2 38S	32	38	57	41	63	72	50	60

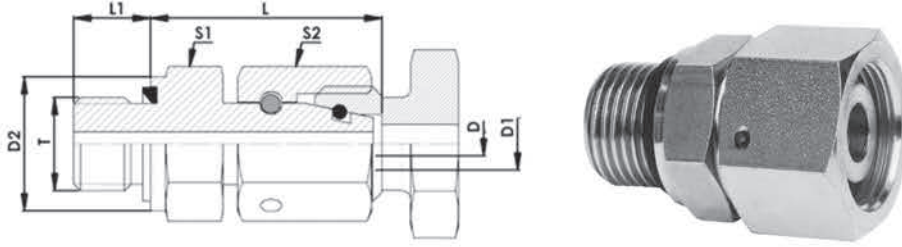

STOK KODU	DIŞ ÖLÇÜSÜ D1	DIŞ ÖLÇÜSÜ T	D	D2	L	L1	S1	S2
TFGETR1006LP	M12X1,5 06L	1/8-28	2,5	14	24,5	8	14	14
TFGETR1306LP	M12X1,5 06L	1/4-19	2,5	19	25	12	19	14
TFGETR1008LP	M14X1,5 08L	1/8-28	4	14	25	8	14	17
TFGETR1308LP	M14X1,5 08L	1/4-19	4	19	29,5	12	19	17
TFGETR1708LP	M14X1,5 08L	3/8-19	4	22	27,5	12	22	17
TFGETR1310LP	M16X1,5 10L	1/4-19	6	19	27,5	12	19	19
TFGETR1710LP	M16X1,5 10L	3/8-19	6	22	29	12	22	19
TFGETR2110LP	M16X1,5 10L	1/2-14	6	27	27,5	14	27	19
TFGETR1312LP	M18X1,5 12L	1/4-19	8	19	27,5	12	19	22
TFGETR1712LP	M18X1,5 12L	3/8-19	8	22	34	12	22	22
TFGETR2112LP	M18X1,5 12L	1/2-14	8	27	29,5	14	27	22
TFGETR1715LP	M22X1,5 15L	3/8-19	10	22	31,5	12	22	27
TFGETR2115LP	M22X1,5 15L	1/2-14	10	27	32	14	27	27
TFGETR2118LP	M26X1,5 18L	1/2-14	13	27	31,5	14	27	32
TFGETR2618LP	M26X1,5 18L	3/4-14	13	32	29,5	16	32	32
TFGETR2122LP	M30X2 22L	1/2-14	17	27	32	14	27	36
TFGETR2622LP	M30X2 22L	3/4-14	17	32	32,5	16	32	36
TFGETR3322LP	M30X2 22L	1"-11	17	41	34	18	41	36
TFGETR2628LP	M36X2 28L	3/4-14	22	32	33,5	16	32	41
TFGETR3328LP	M36X2 28L	1"-11	22	41	35	18	41	41
TFGETR4228LP	M36X2 28L	1"1/4-11	22	50	37	20	50	41
TFGETR3335LP	M45X2 35L	1"-11	28	41	39,5	18	41	50
TFGETR4235LP	M45X2 35L	1"1/4-11	28	50	42,5	20	50	50
TFGETR4242LP	M52X2 42L	1"1/4-11	34	50	44,5	20	50	60
TFGETR4842LP	M52X2 42L	1"1/2-11	34	55	46,5	22	55	60

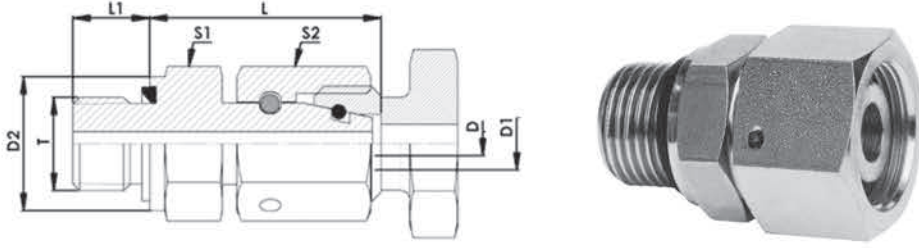

STOK KODU	Diş Ölçüsü D1	Diş Ölçüsü T	D	D2	L	L1	S1	S2
TFGETR1306SP	M14X1,5 06S	1/4-19	2,5	19	27	12	19	17
TFGETR1308SP	M16X1,5 08S	1/4-19	4	19	29,5	12	19	19
TFGETR1708SP	M16X1,5 08S	3/8-19	4	22	31,5	12	22	19
TFGETR1310SP	M18X1,5 10S	1/4-19	6	19	30,5	12	19	22
TFGETR1710SP	M18X1,5 10S	3/8-19	6	22	32	12	22	22
TFGETR1312SP	M20X1,5 12S	1/4-19	8	19	31,5	12	19	24
TFGETR1712SP	M20X1,5 12S	3/8-19	8	22	34	12	22	24
TFGETR2112SP	M20X1,5 12S	1/2-14	8	27	35	14	27	24
TFGETR2114SP	M22X1,5 14S	1/2-14	9	27	36,5	14	27	27
TFGETR1716SP	M24X1,5 16S	3/8-19	11	22	39,5	12	22	30
TFGETR2116SP	M24X1,5 16S	1/2-14	11	27	37	14	27	30
TFGETR2616SP	M24X1,5 16S	3/4-14	11	32	39,5	16	32	30
TFGETR2120SP	M30X2 20S	1/2-14	14	27	41,5	14	27	36
TFGETR2620SP	M30X2 20S	3/4-14	14	32	43	16	32	36
TFGETR3320SP	M30X2 20S	1"-11	14	41	45,5	18	41	36
TFGETR2625SP	M36X2 25S	3/4-14	18	32	45,5	16	32	46
TFGETR3325SP	M36X2 25S	1"-11	18	41	48	18	41	46
TFGETR4225SP	M36X2 25S	1"1/4-11	18	50	48,5	20	50	46
TFGETR3330SP	M42X2 30S	1"-11	23	41	50,5	18	41	50
TFGETR4230SP	M42X2 30S	1"1/4-11	23	50	51	20	50	50
TFGETR4238SP	M52X2 38S	1"1/4-11	30	50	53	20	50	60
TFGETR4838SP	M52X2 38S	1"1/2-11	30	55	60	22	55	60

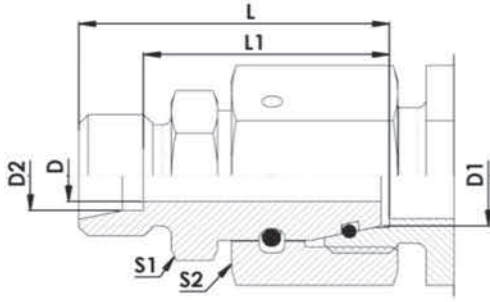

STOK KODU	DIŞ ÖLÇÜSÜ D1	DIŞ ÖLÇÜSÜ D2	D	L	L1	L2	S1	S2	S3
TFKO08L06L	M14X1,5 08L	M12X1,5 06L	4	30,5	23,5	38	12	17	14
TFKO10L06L	M16X1,5 10L	M12X1,5 06L	4	32	25	40	14	19	14
TFKO10L08L	M16X1,5 10L	M14X1,5 08L	6	32	25	40	14	19	17
TFKO12L08L	M18X1,5 12L	M14X1,5 08L	6	32	25	40	17	22	17
TFKO12L10L	M18X1,5 12L	M16X1,5 10L	6	33	26	41	17	22	19
TFKO15L10L	M22X1,5 15L	M16X1,5 10L	8	36,5	29,5	44	19	27	19
TFKO15L12L	M22X1,5 15L	M18X1,5 12L	10	36,5	29,5	44	19	27	22
TFKO18L12L	M26X1,5 18L	M18X1,5 12L	10	36	29	44	24	32	22
TFKO18L15L	M26X1,5 18L	M22X1,5 15L	12	37	30	45	24	32	27
TFKO22L15L	M30X2 22L	M22X1,5 15L	12	41	34	49	27	36	27
TFKO22L18L	M30X2 22L	M26X1,5 18L	15	41	33,5	50	27	36	32
TFKO28L15L	M36X2 28L	M22X1,5 15L	12	43	36	51	32	41	27
TFKO28L18L	M36X2 28L	M26X1,5 18L	15	43	35,5	52	32	41	32
TFKO28L22L	M36X2 28L	M30X2 22L	19	45	37,5	54	32	41	36
TFKO35L18L	M45X2 35L	M26X1,5 18L	15	46	38,5	55	41	50	32
TFKO35L22L	M45X2 35L	M30X2 22L	19	48	40,5	57	41	50	36
TFKO35L28L	M45X2 35L	M36X2 28L	24	48	40,5	57	41	50	41
TFKO42L28L	M52X2 42L	M36X2 28L	24	51,5	44	61	50	60	41
TFKO42L35L	M52X2 42L	M45X2 35L	30	53,5	43	65	50	60	50
S TİPİ									
TFKO10S08S	M18X1,5 10S	M16X1,5 08S	5	34,5	27,5	42	17	22	19
TFKO12S10S	M20X1,5 12S	M18X1,5 10S	7	37	29,5	46	19	24	22
TFKO16S10S	M24X1,5 16S	M18X1,5 10S	7	39	31,5	48	22	30	22
TFKO16S12S	M24X1,5 16S	M20X1,5 12S	8	39	31,5	48	22	30	24
TFKO20S12S	M30X2 20S	M20X1,5 12S	8	43	35,5	52	27	36	24
TFKO20S16S	M30X2 20S	M24X1,5 16S	12	45	36,5	55	27	36	30
TFKO25S12S	M36X2 25S	M20X1,5 12S	8	45,5	38	54	32	46	24
TFKO25S16S	M36X2 25S	M24X1,5 16S	12	47,5	39	57	32	46	30
TFKO25S20S	M36X2 25S	M30X2 20S	16	49,5	39	61	32	46	36
TFKO30S12S	M42X2 30S	M20X1,5 12S	8	51	43,5	60	41	50	24
TFKO30S16S	M42X2 30S	M24X1,5 16S	12	53	44,5	63	41	50	30
TFKO30S20S	M42X2 30S	M30X2 20S	16	55	44,5	66	41	50	36
TFKO30S25S	M42X2 30S	M36X2 25S	20	57	45	69	41	50	46
TFKO38S20S	M52X2 38S	M30X2 20S	16	58,5	48	70	50	60	36
TFKO38S25S	M52X2 38S	M36X2 25S	20	60,5	48,5	73	50	60	46
TFKO38S30S	M52X2 38S	M42X2 30S	25	62,5	49	76	50	60	50

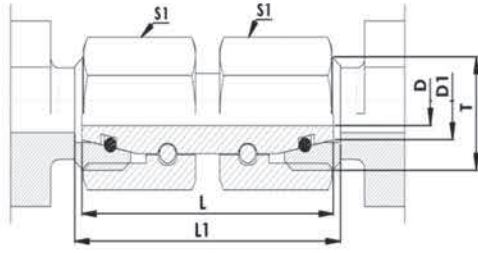

STOK KODU	T	D1	D	L	L1	S1
TFGNT06LT06L	M12X1,5	6	2,5	32	33	14
TFGNT08LT08L	M14X1,5	8	4	32	33	17
TFGNT10LT10L	M16X1,5	10	6	33	34	19
TFGNT12LT12L	M18X1,5	12	8	33	34	22
TFGNT15LT15L	M22X1,5	15	10	38	39	27
TFGNT18LT18L	M26X1,5	18	13	36	38	32
TFGNT22LT22L	M30X2	22	17	42	44	36
TFGNT28LT28L	M36X2	28	22	46	48	41
TFGNT35LT35L	M45X2	35	28	48	52	50
TFGNT42LT42L	M52X2	42	34	52	57	60
S TİPİ						
TFGNT06ST06S	M14X1,5	6	2,5	32	33	17
TFGNT08ST08S	M16X1,5	8	4	33	34	19
TFGNT10ST10S	M18X1,5	10	6	33	35	22
TFGNT12ST12S	M20X1,5	12	8	36	38	24
TFGNT14ST14S	M22X1,5	14	9	36	41	27
TFGNT16ST16S	M24X1,5	16	11	39	42	30
TFGNT20ST20S	M30X2	20	14	44	48	36
TFGNT25ST25S	M36X2	25	18	46	53	46
TFGNT30ST30S	M42X2	30	23	52	62	50
TFGNT38ST38S	M52X2	38	30	52	67	60

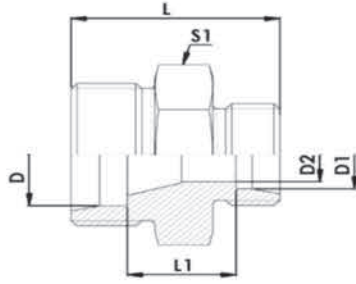

STOK KODU	DIŞ ÖLÇÜSÜ D	DIŞ ÖLÇÜSÜ D1	D2	L	L1	L2	S1	S2	S3
TFGND08L06L	M14X1,5 08L	M12X1,5 06L	4	25	11	40	14	17	14
TFGND10L06L	M16X1,5 10L	M12X1,5 06L	4	26	12	41	17	19	14
TFGND10L08L	M16X1,5 10L	M14X1,5 08L	6	26	12	41	17	19	17
TFGND12L06L	M18X1,5 12L	M12X1,5 06L	4	27	13	42	19	22	14
TFGND12L08L	M18X1,5 12L	M14X1,5 08L	6	27	13	42	19	22	17
TFGND12L10L	M18X1,5 12L	M16X1,5 10L	8	28	14	43	19	22	19
TFGND15L10L	M22X1,5 15L	M16X1,5 10L	8	29	15	45	24	27	19
TFGND15L12L	M22X1,5 15L	M18X1,5 12L	10	29	15	45	24	27	22
TFGND18L10L	M26X1,5 18L	M16X1,5 10L	8	30	15,5	46	27	32	19
TFGND18L12L	M26X1,5 18L	M18X1,5 12L	10	30	15,5	46	27	32	22
TFGND18L15L	M26X1,5 18L	M22X1,5 15L	12	31	16,5	48	27	32	27
TFGND22L12L	M30X2 22L	M18X1,5 12L	10	32	17,5	48	32	36	22
TFGND22L15L	M30X2 22L	M22X1,5 15L	12	33	18,5	50	32	36	27
TFGND22L18L	M30X2 22L	M26X1,5 18L	15	33	18	50	32	36	32
TFGND28L18L	M36X2 28L	M26X1,5 18L	15	34	19	52	41	41	32
TFGND28L22L	M36X2 28L	M30X2 22L	19	36	21	54	41	41	36
TFGND35L22L	M45X2 35L	M30X2 22L	19	39	21	59	46	50	36
TFGND35L28L	M45X2 35L	M36X2 28L	24	39	21	59	46	50	41
TFGND42L35L	M52X2 42L	M45X2 35L	30	43	21,5	66	55	60	50
S TİPİ									
TFGND08S06S	M16X1,5 08S	M14X1,5 06S	4	32	18	47	17	19	17
TFGND10S08S	M18X1,5 10S	M16X1,5 08S	5	32	17,5	48	19	22	19
TFGND12S10S	M20X1,5 12S	M18X1,5 10S	7	34	19	51	22	24	22
TFGND16S12S	M24X1,5 16S	M20X1,5 12S	8	36	20	54	27	30	24
TFGND20S12S	M30X2 20S	M20X1,5 12S	8	40	22	60	32	36	24
TFGND20S16S	M30X2 20S	M24X1,5 16S	12	42	23	63	32	36	30
TFGND25S16S	M36X2 25S	M24X1,5 16S	12	46	25,5	68	41	46	30
TFGND25S20S	M36X2 25S	M30X2 20S	16	48	25,5	71	41	46	36
TFGND30S20S	M42X2 30S	M30X2 20S	16	50	26	74	46	50	36
TFGND30S25S	M42X2 30S	M36X2 25S	20	52	26,5	77	46	50	46
TFGND38S30S	M52X2 38S	M42X2 30S	25	59	29,5	87	55	60	50

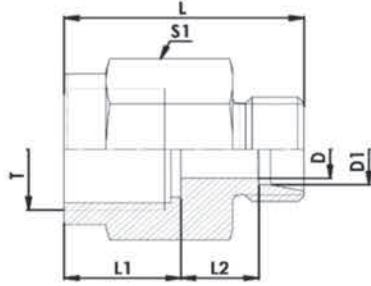

STOK KODU	DİŞ ÖLÇÜSÜ D1	DİŞ ÖLÇÜSÜ T	D	L	L1	L2	L3	S1	S2
TFMAR1306L	M12X1,5 06L	1/4-19	4	28,5	10	11,5	36,5	19	14
TFMAR1308L	M14X1,5 08L	1/4-19	6	28,5	10	11,5	36,5	19	17
TFMAR1310L	M16X1,5 10L	1/4-19	8	29,5	10	12,5	37,5	19	19
TFMAR1312L	M18X1,5 12L	1/4-19	9	29,5	10	12,5	37,5	19	22
S TİPİ									
TFMAR1306S	M14X1,5 06S	1/4-19	4	30,5	10	13,5	38,5	19	17
TFMAR1308S	M16X1,5 08S	1/4-19	5	30,5	10	13,5	38,5	19	19
TFMAR1310S	M18X1,5 10S	1/4-19	7	30,5	10	13	38,5	19	22
TFMAR1312S	M20X1,5 12S	1/4-19	8	30,5	10	13	38,5	19	24
TFMAR2106S	M14X1,5 06S	1/2-14	4	38	16,5	14,5	46	27	17
TFMAR2108S	M16X1,5 08S	1/2-14	5	38	16,5	14,5	46	27	19
TFMAR2110S	M18X1,5 10S	1/2-14	7	38	16,5	14,5	46	27	22
TFMAR2112S	M20X1,5 12S	1/2-14	8	38	16,5	14,5	46	27	24

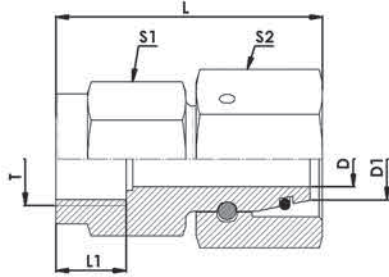

STOK KODU	DIŞ ÖLÇÜSÜ T	DIŞ ÖLÇÜSÜ D1	D	L	L1	S1	S2
TFMAR13T06L	M12X1,5 06L	1/4-19	2,5	34,7	10	19	14
TFMAR13T08L	M14X1,5 08L	1/4-19	4	34,7	10	19	17
TFMAR13T10L	M16X1,5 10L	1/4-19	6	35,2	10	19	19
TFMAR13T12L	M18X1,5 12L	1/4-19	8	36,7	10	19	22
S TİPİ							
TFMAR13T06S	M14X1,5 06S	1/4-19	2,5	34,7	10	19	17
TFMAR13T08S	M16X1,5 08S	1/4-19	4	34,7	10	19	19
TFMAR13T10S	M18X1,5 10S	1/4-19	6	37,2	10	19	22
TFMAR13T12S	M20X1,5 12S	1/4-19	8	37,2	10	19	24
TFMAR21T06S	M14X1,5 06S	1/2-14	2,5	42,2	16,5	27	17
TFMAR21T08S	M16X1,5 08S	1/2-14	4	45,2	16,5	27	19
TFMAR21T10S	M18X1,5 10S	1/2-14	6	44,7	16,5	27	22
TFMAR21T12S	M20X1,5 12S	1/2-14	8	44,7	16,5	19	24

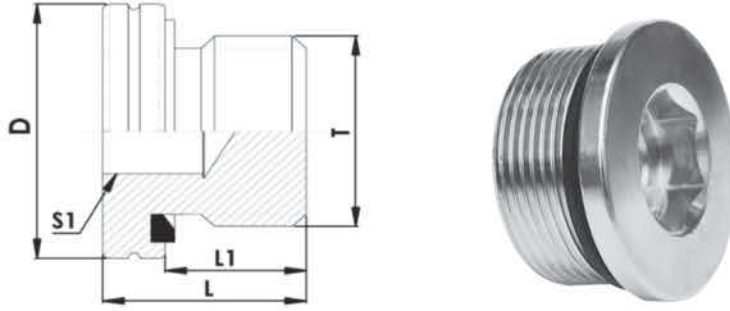

STOK KOD	DİŞ ÖLÇÜSÜ T	L	L1	D	S1
TFKTAM10P	M10X1	12	8	14	5
TFKTAM12P	M12X1,5	17	12	17	6
TFKTAM14P	M14X1,5	17	12	19	6
TFKTAM16P	M16X1,5	17	12	22	8
TFKTAM18P	M18X1,5	17	12	24	8
TFKTAM20P	M20X1,5	19	14	26	10
TFKTAM22P	M22X1,5	19	14	27	10
TFKTAM26P	M26X1,5	21	16	32	12

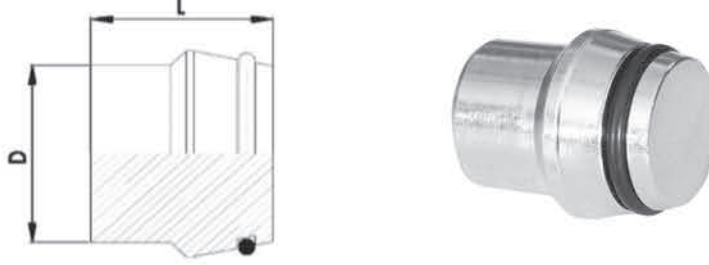

STOK KODU	BORU ÇAPI	D	L
TFKT06	06L/S	6	18,5
TFKT08	08L/S	8	18,5
TFKT10	10L/S	10	20
TFKT12	12L/S	12	20,5
TFKT15	15L	15	20,5
TFKT18	18L	18	22,5
TFKT22	22L	22	25
TFKT28	28L	28	25,5
TFKT35	35L	35	30
TFKT42	42L	42	30
S TİPİ			
TFKT14	14S	14	20,5
TFKT16	16S	16	23,5
TFKT20	20S	20	28,5
TFKT25	25S	25	29
TFKT30	30S	30	30,5
TFKT38	38S	38	33

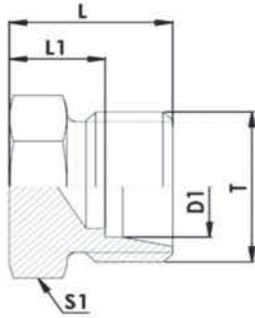

STOK KODU	DİŞ ÖLÇÜSÜ T	D1	L	L1	L2	S1	S2
TFKTE06L	M12X1,5 06L	6	14	7	22	12	14
TFKTE08L	M14X1,5 08L	8	15	8	23	14	17
TFKTE10L	M16X1,5 10L	10	16	9	24	17	19
TFKTE12L	M18X1,5 12L	12	17	10	25	19	22
TFKTE15L	M22X1,5 15L	15	18	11	26	24	27
TFKTE18L	M26X1,5 18L	18	19	11,5	28	27	32
TFKTE22L	M30X2 22L	22	21	13,5	30	32	36
TFKTE28L	M36X2 28L	28	22	14,5	31	41	41
TFKTE35L	M45X2 35L	35	25	14,5	36	46	50
TFKTE42L	M52X2 42L	42	27	16	39	55	60
S TİPİ							
TFKTE06S	M14X1,5 06S	6	18	11	26	14	17
TFKTE08S	M16X1,5 08S	8	20	13	28	17	19
TFKTE10S	M18X1,5 10S	10	20	12,5	29	19	22
TFKTE12S	M20X1,5 12S	12	22	14,5	31	22	24
TFKTE14S	M22X1,5 14S	14	24	16	34	24	27
TFKTE16S	M24X1,5 16S	16	24	15,5	34	27	30
TFKTE20S	M30X2 20S	20	28	17,5	39	32	36
TFKTE25S	M36X2 25S	25	32	20	44	41	46
TFKTE30S	M42X2 30S	30	34	20,5	47	46	50
TFKTE38S	M52X2 38S	38	39	23	54	55	60

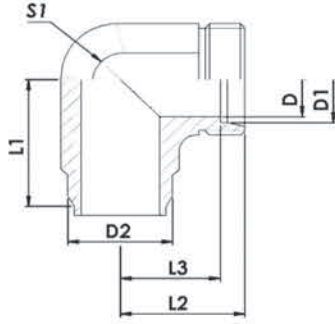

STOK KODU	DIŞ ÖLÇÜSÜ	D	D1	D2	L1	L2	L3	L4	S1	S2
TFDIK06L	M12X1,5 06L	4	6	10	19	19	12	27	12	14
TFDIK08L	M14X1,5 08L	6	8	12	23	21	14	29	12	17
TFDIK10L	M16X1,5 10L	8	10	14	24	22	15	30	14	19
TFDIK12L	M18X1,5 12L	10	12	16	25	24	17	32	17	22
TFDIK15L	M22X1,5 15L	12	15	19	30	28	21	36	19	27
TFDIK18L	M26X1,5 18L	15	18	22	33	31	23,5	40	24	32
TFDIK22L	M30X2 22L	19	22	27	37	35	27,5	44	27	36
TFDIK28L	M36X2 28L	24	28	32	41	38	30,5	47	36	41
TFDIK35L	M45X2 35L	30	35	40	49	45	34,5	56	41	50
TFDIK42L	M52X2 42L	36	42	46	55	51	40	63	50	60
S TİPİ										
TFDIK06S	M14X1,5 06S	4	6	11	23	23	16	31	12	17
TFDIK08S	M16X1,5 08S	5	8	13	24	24	17	32	14	19
TFDIK010S	M18X1,5 10S	7	10	15	25	25	17,5	34	17	22
TFDIK12S	M20X1,5 12S	8	12	17	29	29	21,5	38	17	24
TFDIK14S	M22X1,5 14S	10	14	19	30	30	22	40	19	27
TFDIK16S	M24X1,5 16S	12	16	21	33	33	24,5	43	24	30
TFDIK20S	M30X2 20S	16	20	26	37	37	26,5	48	27	36
TFDIK25S	M36X2 25S	20	25	31	42	42	30	54	36	46
TFDIK30S	M42X2 30S	25	30	36	49	49	35,5	62	41	50
TFDIK38S	M52X2 38S	32	38	44	57	57	41	72	50	60

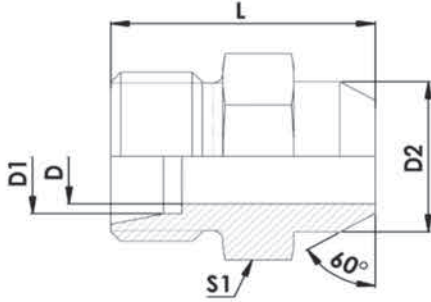

STOK KODU	DIŞ ÖLÇÜSÜ	D	D1	D2	L	L1	S1	S2
TFGEK06L	M12X1,5 06L	4	6	10	21	29	12	14
TFGEK08L	M14X1,5 08L	6	8	12	23	31	14	17
TFGEK10L	M16X1,5 10L	8	10	14	25	33	17	19
TFGEK12L	M18X1,5 12L	10	12	16	25	33	19	22
TFGEK15L	M22X1,5 15L	12	15	19	29	37	22	27
TFGEK18L	M26X1,5 18L	15	18	22	31	40	27	32
TFGEK22L	M30X2 22L	19	22	27	36	45	32	36
TFGEK28L	M36X2 28L	24	28	32	38	47	41	41
TFGEK35L	M45X2 35L	30	35	40	43	54	46	50
TFGEK42L	M52X2 42L	36	42	46	46	58	55	60
S TİPİ								
TFGEK06S	M14X1,5 06S	4	6	11	26	34	14	17
TFGEK08S	M16X1,5 08S	5	8	13	28	36	17	19
TFGEK10S	M18X1,5 10S	7	10	15	30	39	19	22
TFGEK12S	M20X1,5 12S	8	12	17	32	41	22	24
TFGEK14S	M22X1,5 14S	10	14	19	35	45	24	27
TFGEK16S	M24X1,5 16S	12	16	21	35	45	27	30
TFGEK20S	M30X2 20S	16	20	26	40	51	32	36
TFGEK25S	M36X2 25S	20	25	31	44	56	41	46
TFGEK30S	M42X2 30S	25	30	36	49	62	46	50
TFGEK38S	M52X2 38S	32	38	44	54	69	55	60

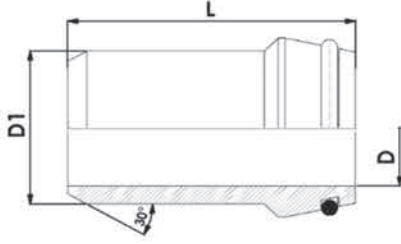

STOK KODU	DIŞ ÖLÇÜSÜ D1	D	L	L1
TFKUK06L	6	3	31	31,5
TFKUK08L	8	4	31	31,5
TFKUK10L	10	7	32,5	33,5
TFKUK12L	12	8	32,5	33,5
TFKUK15L	15	10	34	34,5
TFKUK18L	18	13	35,5	36,5
TFKUK22L	22	17	38,5	39,5
TFKUK28L	28	22	41,5	42,5
TFKUK35L	35	27	47,5	49,5
TFKUK42L	42	34	47,5	50
S TİPİ				
TFKUK14S	14	8	38,5	39,5
TFKUK16S	16	11	39	40,5
TFKUK20S	20	15	45	47
TFKUK25S	25	17	49,5	53
TFKUK30S	30	20	52	57
TFKUK38S	38	28	56,5	64

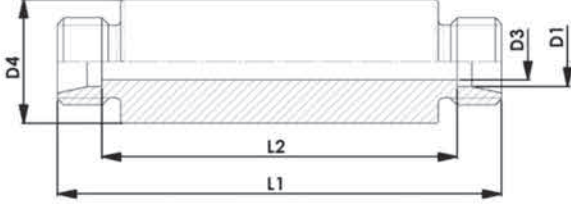

STOK KODU	DİŞ ÖLÇÜSÜ D1	D3	D4	L1	L2	L3	S1
TFPGK06L	M12X1,5 06L	4	18	70	56	85	14
TFPGK08L	M14X1,5 08L	6	20	70	56	85	17
TFPGK10L	M16X1,5 10L	8	22	72	58	87	19
TFPGK12L	M18X1,5 12L	10	25	72	58	87	22
TFPGK15L	M22X1,5 15L	12	28	84	70	100	27
TFPGK18L	M26X1,5 18L	15	32	84	69	101	32
TFPGK22L	M30X2 22L	19	36	88	73	105	36
TFPGK28L	M36X2 28L	24	40	88	73	106	41
TFPGK35L	M45X2 35L	30	50	92	71	114	50
TFPGK42L	M52X2 42L	36	60	92	70	115	60
S TİPİ							
TFPG06S	M14X1,5 06S	4	20	74	60	89	17
TFPG08S	M16X1,5 08S	5	22	74	60	89	19
TFPG10S	M18X1,5 10S	7	25	74	59	91	22
TFPG12S	M20X1,5 12S	8	28	74	59	91	24
TFPG14S	M22X1,5 14S	10	30	88	72	107	27
TFPG16S	M24X1,5 16S	12	35	88	71	107	30
TFPG20S	M30X2 20S	16	38	92	71	114	36
TFPG25S	M36X2 25S	20	45	96	72	120	46
TFPG30S	M42X2 30S	25	50	100	73	126	50
TFPG38S	M52X2 38S	32	60	104	72	133	60

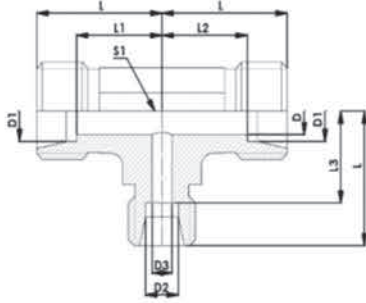

STOK KODU	DIŞ ÖLÇÜSÜ D1	DIŞ ÖLÇÜSÜ D1	DIŞ ÖLÇÜSÜ D2	D	D3	L	L1	L2	L3	L4	L5	L6	S1	S2	S3
TFTE06LG08L	6	6	8	4	6	21	14	14	14	29	29	29	12	14	17
TFTE08LG06L	8	8	6	6	4	21	14	14	14	29	29	29	12	17	14
TFTE06LG10L	6	6	10	4	8	22	15	15	15	30	30	30	14	14	19
TFTE08LG10L	8	8	10	6	8	22	15	15	15	30	30	30	14	17	19
TFTE10LG06L	10	10	6	8	4	22	15	15	15	30	30	30	14	19	14
TFTE10LG08L	10	10	8	8	6	22	15	15	15	30	30	30	14	19	17
TFTE08LG12L	8	8	12	6	10	24	17	17	17	32	32	32	17	17	22
TFTE12LG06L	12	12	6	10	4	24	17	17	17	32	32	32	17	22	14
TFTE12LG08L	12	12	8	10	6	24	17	17	17	32	32	32	17	22	17
TFTE12LG10L	12	12	10	10	8	24	17	17	17	32	32	32	17	22	19
TFTE10LG15L	10	10	15	8	12	28	21	21	21	36	36	36	19	19	27
TFTE12LG15L	12	12	15	10	12	28	21	21	21	36	36	36	19	22	27
TFTE15LG06L	15	15	6	12	4	28	21	21	21	36	36	36	19	27	14
TFTE15LG10L	15	15	10	12	8	28	21	21	21	36	36	36	19	27	19
TFTE15LG12L	15	15	12	12	10	28	21	21	21	36	36	36	19	22	22
TFTE12LG18L	12	12	18	10	15	31	24	24	24	39	39	40	24	27	22
TFTE18LG10L	18	18	10	15	8	31	24	24	24	40	40	39	24	22	32
TFTE18LG12L	18	18	12	15	10	31	24	24	24	40	40	39	24	32	19
TFTE18LG15L	18	18	15	15	12	31	24	24	24	40	40	39	24	32	22
TFTE22LG10L	22	22	10	19	8	35	28	28	28	44	44	43	27	32	27
TFTE22LG12L	22	22	12	19	10	35	28	28	28	44	44	43	27	36	19
TFTE22LG15L	22	22	15	19	12	35	28	28	28	44	44	43	27	36	22
TFTE22LG18L	22	22	18	19	15	35	28	28	28	44	44	44	27	36	27
TFTE28LG10L	28	28	10	24	8	38	31	31	31	47	47	46	36	36	32
TFTE28LG12L	28	28	12	24	10	38	31	31	31	47	47	46	36	41	19
TFTE28LG15L	28	28	15	24	12	38	31	31	31	47	47	46	36	41	22
TFTE28LG18L	28	28	18	24	15	38	31	31	31	47	47	47	36	41	27
TFTE28LG22L	28	28	22	24	19	38	31	31	31	47	47	47	36	41	32
S TİPİ															
TFTE10SG06S	10	10	6	7	4	25	18	18	18	34	34	33	17	22	17
TFTE12SG08S	12	12	8	8	5	29	22	22	22	38	38	37	17	24	19
TFTE12SG10S	12	12	10	8	7	29	22	22	22	38	38	38	17	24	22
TFTE12SG16S	12	12	16	8	12	33	26	26	25	42	42	43	24	24	30
TFTE16SG06S	16	16	6	12	4	33	25	25	26	43	43	41	24	30	17
TFTE16SG08S	16	16	8	12	5	33	25	25	26	43	43	41	24	30	19
TFTE16SG10S	16	16	10	12	7	33	25	25	26	43	43	42	24	30	22
TFTE16SG10S	16	16	12	12	8	33	25	25	26	43	43	42	24	30	24
TFTE16SG20S	16	16	20	12	16	37	29	29	27	47	47	48	27	30	36
TFTE20SG20S	20	20	10	16	7	37	27	27	30	48	48	46	27	36	22
TFTE20SG12S	20	20	12	16	8	37	27	27	30	48	48	46	27	36	24
TFTE20SG16S	20	20	16	16	12	37	27	27	29	48	48	47	27	36	30
TFTE20SG25S	20	20	25	16	20	42	32	32	30	53	53	54	36	36	46
TFTE25SG16S	25	25	16	20	12	42	30	30	34	54	54	52	36	46	30
TFTE25SG20S	25	25	20	20	16	42	30	30	32	54	54	53	36	46	36
TFTE25SG30S	25	25	30	20	25	49	37	37	36	61	61	62	41	46	50

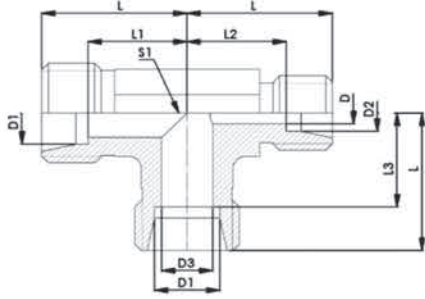

STOK KODU	DIŞ ÖLÇÜSÜ D1	DIŞ ÖLÇÜSÜ D1	DIŞ ÖLÇÜSÜ D2	D	D3	L	L1	L2	L3	L4	L5	L6	S1	S2	S3
TFTE10LF06L	10	10	6	4	8	22	15	15	15	30	30	30	14	19	14
TFTE10LF12L	10	10	12	8	8	24	17	17	17	32	32	32	17	22	19
TFTE10LF18L	10	10	18	8	8	31	23,5	24	24	40	39	39	24	19	32
TFTE12LF10L	12	12	10	8	10	24	17	17	17	32	32	32	17	22	19
TFTE12LF15L	12	12	15	10	10	28	21	21	21	36	36	36	19	22	27
TFTE15LF12L	15	15	12	10	12	28	21	21	21	36	36	36	19	27	22
TFTE15LF22L	15	15	22	12	12	35	28	27,5	28	43	44	43	27	36	27
TFTE18LF10L	18	18	10	8	15	31	23,5	24	23,5	40	39	40	24	32	19
TFTE22LF18L	22	22	18	15	19	35	27,5	27,5	27,5	44	44	44	27	36	32
TFTE22LF28L	22	22	28	19	19	38	30,5	30,5	30,5	47	47	47	36	36	41
S TİPİ															
TFTE08SF08S	8	8	12	5	5	29	22	21,5	22	37	38	37	17	19	24

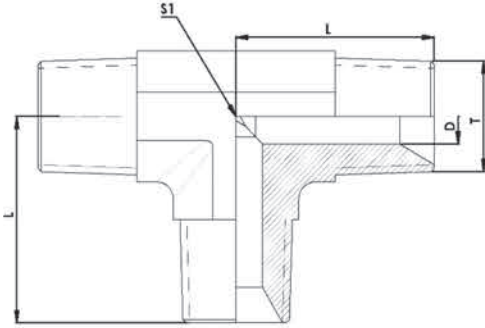

STOK KODU	DİŞ ÖLÇÜSÜ T	D	L	S1
TFTER10	1/8-28 BSPT	5	20	12
TFTER13	1/4-19 BSPT	7	27	14
TFTER17	3/8-19 BSPT	8	28	19
TFTER21	1/2-14 BSPT	11	36	22
TFTER26	3/4-14 BSPT	16	42	27
TFTER33	1"-11 BSPT	21	48	32
TFTER42	1 1/4-11 BSPT	28	54	41
TFTER48	1 1/2-11 BSPT	34	61	50

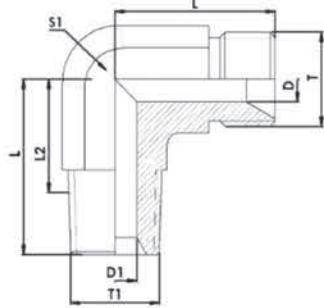

STOK KODU	DIŞ ÖLÇÜSÜ T	DIŞ ÖLÇÜSÜ T1	D	D1	L	L1	L2	S1
TFDIN10R10	1/8-28	1/8-28 BSPT	4	5	21	20	15	12
TFDIN13R13	1/4-19	1/4-19 BSPT	5	7	24	28	15	14
TFDIN17R17	3/8-19	3/8-19 BSPT	8	8	29	31	20	19
TFDIN21R21	1/2-14	1/2-14 BSPT	11	11	33	37	21	22
TFDIN26R26	3/4-14	3/4-14 BSPT	17	16	40	40	28	27
TFDIN33R33	1"-11	1"-11 BSPT	22	21	44	50	29	36
TFDIN42R42	1"1/4-11	1"1/4-11 BSPT	29	28	52	54	37	41
TFDIN48R48	1"1/2-11	1"1/2-11 BSPT	33	34	59	61	44	50

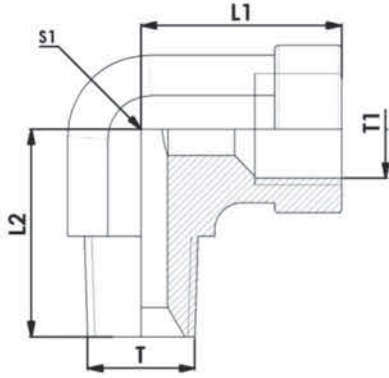

STOK KODU	DİŞ ÖLÇÜSÜ T	DİŞ ÖLÇÜSÜ T1	L1	L2	S1
TFKUR10	1/8-28 BSPT	1/8-28	17	20	14
TFKUR13	1/4-19 BSPT	1/4-19	22,5	28	19
TFKUR17	3/8-19 BSPT	3/8-19	26	31	22
TFKUR21	1/2-14 BSPT	1/2-14	31	37,5	27
TFKUR26	3/4-14 BSPT	3/4-14	34,5	40	33
TFKUR33	1"-11 BSPT	1"-11	41	50	41
TFKUR42	1"1/4-11 BSPT	1"1/4-11	43	60	48
TFKUR48	1"1/2-11 BSPT	1"1/2-11	53	67	65

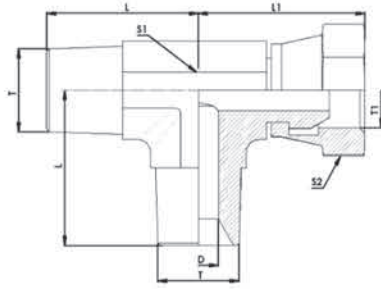

STOK KODU	DİŞ ÖLÇÜSÜ T	DİŞ ÖLÇÜSÜ T1	D	L	L1	S1	S2
TFTEFR10	1/8-28 BSPT	1/8-28	5	20	22	12	14
TFTEFR13	1/4-19 BSPT	1/4-19	7	27	32	14	19
TFTEFR17	3/8-19 BSPT	3/8-19	8	28	33	19	22
TFTEFR21	1/2-14 BSPT	1/2-14	11	36	40	22	27
TFTEFR26	3/4-14 BSPT	3/4-14	16	42	42	27	32
TFTEFR33	1"-11 BSPT	1"-11	21	48	49	32	41
TFTEFR42	1"1/4-11 BSPT	1"1/4-11	28	54	58	41	50
TFTEFR48	1"1/2-11 BSPT	1"1/2-11	34	61	63	50	60

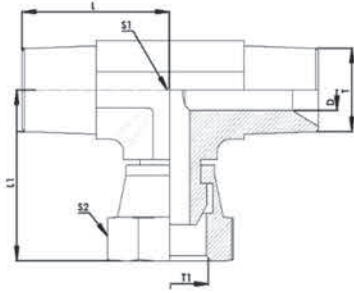

STOK KODU	DIŞ ÖLÇÜSÜ T	DIŞ ÖLÇÜSÜ T1	D	L	L1	S1	S2
TFTEGR10	1/8-28 BSPT	1/8-28	5	20	22	12	14
TFTEGR13	1/4-19 BSPT	1/4-19	7	27	32	14	19
TFTEGR17	3/8-19 BSPT	3/8-19	8	28	33	19	22
TFTEGR21	1/2-14 BSPT	1/2-14	11	36	40	22	27
TFTEGR26	3/4-14 BSPT	3/4-14	16	42	42	27	32
TFTEGR33	1"-11 BSPT	1"-11	21	48	49	32	41
TFTEGR42	1"1/4-11 BSPT	1"1/4-11	28	54	58	41	50
TFTEGR48	1"1/2-11 BSPT	1"1/2-11	34	61	63	50	60

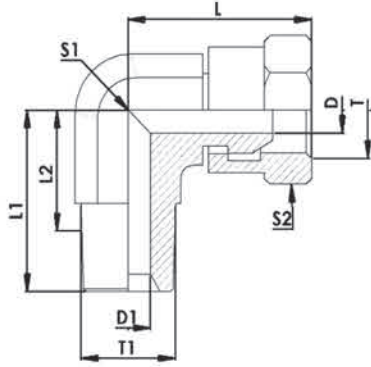

STOK KODU	DIŞ ÖLÇÜSÜ T	DIŞ ÖLÇÜSÜ T1	D	D1	L	L1	L2	S1	S2
TFDIN10TR10	1/8-28	1/8-28 BSPT	3	5	23	20	14	12	14
TFDIN13TR13	1/4-19	1/4-19 BSPT	5	7	32	28	19	14	19
TFDIN17TR17	3/8-19	3/8-19 BSPT	8	8	35	31	22	19	22
TFDIN21TR21	1/2-14	1/2-14 BSPT	11	11	40	37	25	22	27
TFDIN26TR26	3/4-14	3/4-14 BSPT	16	16	42	40	28	27	32
TFDIN33TR33	1"-11	1"-11 BSPT	21	21	49	50	35	36	41
TFDIN42TR42	1"1/4-11	1"1/4-11 BSPT	29	28	58	54	39	41	50
TFDIN48TR48	1"1/2-11	1"1/2-11 BSPT	33	34	63	61	46	50	60

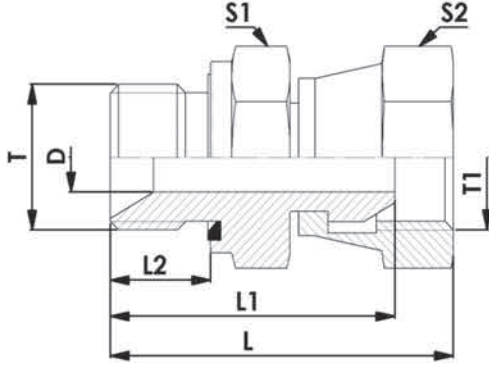

STOK KODU	Diş Ölçüsü T	Diş Ölçüsü T1	D	L	L1	L2	S1	S2
TFGER10TR10P	1/8-28	1/8-28	3	26	24	8	14	14
TFGER13TR13P	1/4-19	1/4-19	5	34	33	11	19	19
TFGER17TR17P	3/8-19	3/8-19	8	39	34	12	22	22
TFGER21TR21P	1/2-14	1/2-14	11	43	40	14	27	27
TFGER26TR26P	3/4-14	3/4-14	17	47	41	16	32	32
TFGER33TR33P	1"-11	1"-11	21	54	46	18	41	41
TFGER42TR42P	1"1/4-11	1"1/4-11	29	65	59	20	50	50
TFGER48TR48P	1"1/2-11	1"1/2-11	33	71	62	22	55	55

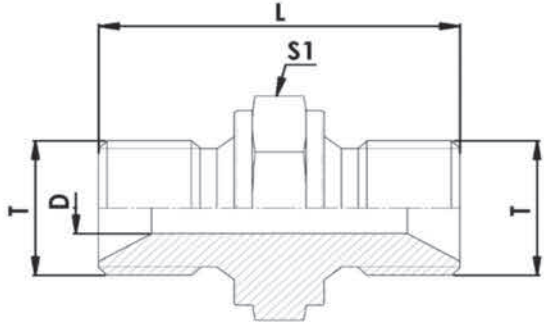

STOK KODU	DIŞ ÖLÇÜSÜ T	D	L	S1
TFGNR10	1/8-28	4	24	14
TFGNR13	1/4-19	5	32	19
TFGNR17	3/8-19	8	35	22
TFGNR21	1/2-14	11	41	27
TFGNR23	5/8-14	14	45	30
TFGNR26	3/4-14	17	45	32
TFGNR33	1"-11	22	52	41
TFGNR42	1"1/4-11	29	61	50
TFGNR48	1"1/2-11	33	67	55
TFGNR60	2"-11	46	76	70

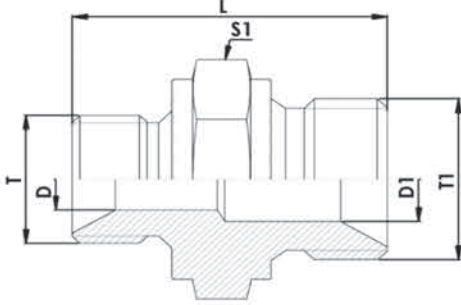

STOK KODU	DIŞ ÖLÇÜSÜ T	DIŞ ÖLÇÜSÜ T1	D	D1	L	S1
TFGNDR10R13	1/8-28	1/4-19	4	5	28	19
TFGNDR10R17	1/8-28	3/8-19	4	8	33	22
TFGNDR13R17	1/4-19	3/8-19	5	8	33	22
TFGNDR13R21	1/4-19	1/2-14	5	11	37	27
TFGNDR13R26	1/4-19	3/4-14	5	17	39	32
TFGNDR17R21	3/8-19	1/2-14	8	11	38	27
TFGNDR17R26	3/8-19	3/4-14	8	17	41	32
TFGNDR21R26	1/2-14	3/4-14	11	17	43	32
TFGNDR21R33	1/2-14	1"-11	11	22	47	41
TFGNDR23R26	5/8-14	3/4-14	14	17	45	32
TFGNDR26R33	3/4-14	1"-11	17	22	49	41
TFGNDR26R42	3/4-14	1"1/4-11	17	29	57	50
TFGNDR26R48	3/4-14	1"1/2-11	17	33	61	55
TFGNDR33R42	1"-11	1"1/4-11	22	29	60	50
TFGNDR33R48	1"-11	1"1/2-11	22	33	64	55
TFGNDR33R66	1"-11	2"-11	22	46	68	70
TFGNDR42R48	1"1/4-11	1"1/2-11	29	33	65	55
TFGNDR42R60	1"1/4-11	2"-11	29	46	69	70
TFGNDR48R60	1"1/2-11	2"-11	33	46	73	70

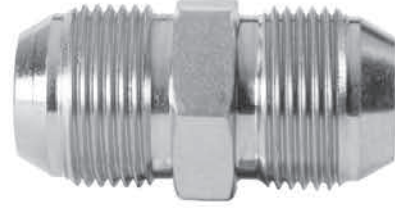
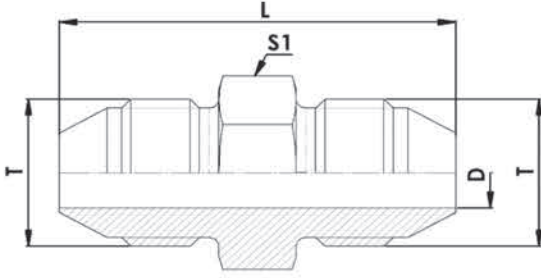

STOK KODU	DIŐA ÖLÇÜSÜ T	D	L	S1
TFGNR13X2	1/4-19	5	39	14
TFGNR17X2	3/8-19	8	41	19
TFGNR21X2	1/2-14	11	48	24
TFGNR26X2	3/4-14	17	50	27
TFGNR33X2	1"-11	22	61	36

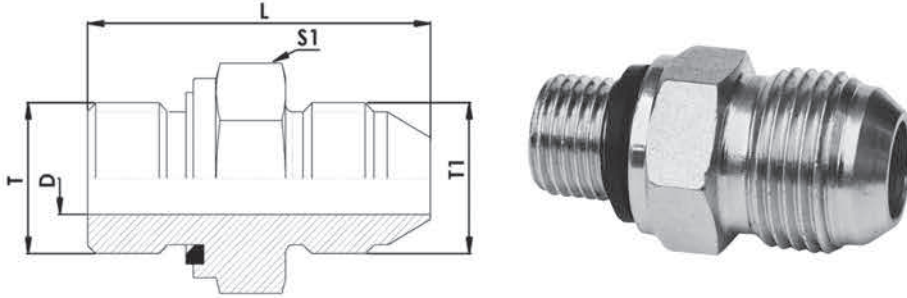

STOK KODU	DIŐ ÖLÇÜSÜ T	DIŐ ÖLÇÜSÜ T1	D	L	S1
TFGER13PX1	1/4-19	1/4-19	5	38,5	19
TFGER17PX1	3/8-19	3/8-19	8	47	27
TFGER21PX1	1/2-14	1/2-14	11	39	22
TFGER26PX1	3/4-14	3/4-14	17	51	32
TFGER33PX1	1"-11	1"-11	22	58	41

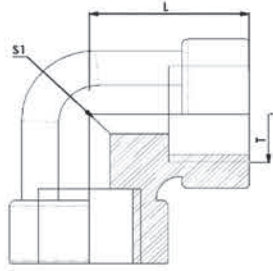

STOK KODU	DİŐ ÖLÇÜŐÜ T	L	S1
TFDIUR10	1/8-28	17	14
TFDIUR13	1/4-19	22	19
TFDIUR17	3/8-19	26	22
TFDIUR21	1/2-14	31	27
TFDIUR26	3/4-14	40	32
TFDIUR33	1"-11	46	41
TFDIUR42	1"1/4-11	46	50

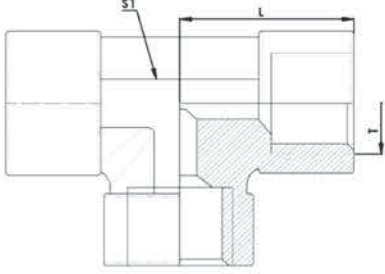

STOK KODU	DİŞ ÖLÇÜSÜ T	L	S1
TFTEUR10	1/8-28	17	14
TFTEUR13	1/4-19	22	19
TFTEUR17	3/8-19	26	22
TFTEUR21	1/2-14	31	27
TFTEUR26	3/4-14	40	32
TFTEUR33	1"-11	46	41
TFTEUR42	1"1/4-11	46	50

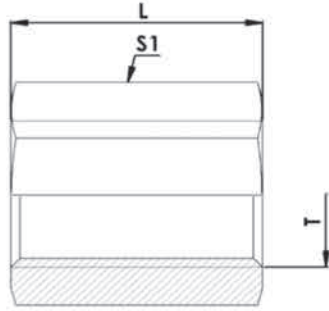

STOK KODU	DİŞ ÖLÇÜSÜ T	L	S1
TFMSHR10	1/8-28	19	14
TFMSHR13	1/4-19	28	17
TFMSHR17	3/8-19	28	22
TFMSHR21	1/2-14	33	27
TFMSHR26	3/4-14	37	32
TFMSHR33	1"-11	42	41
TFMSHR42	1"1/4-11	46	50
TFMSHR48	1"1/2-11	50	55
TFMSHR60	2"-11	54	75

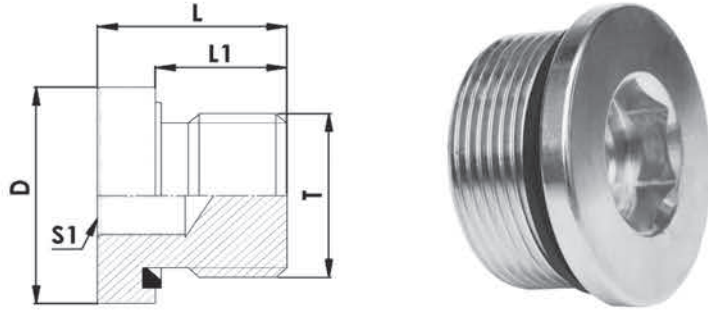

STOK KODU	DIŞ ÖLÇÜSÜ T	L	L1	D	S1
TFKTAR10P	1/8-28	12	8	14	5
TFKTAR13P	1/4-19	17	12	19	6
TFKTAR17P	3/8-19	17	12	22	8
TFKTAR21P	1/2-14	19	14	27	10
TFKTAR26P	3/4-14	21	16	32	12
TFKTAR33P	1"-11	22,5	16	40	17
TFKTAR42P	1"1/4-11	22,5	16	50	22
TFKTAR48P	1"1/2-11	22,5	16	55	24

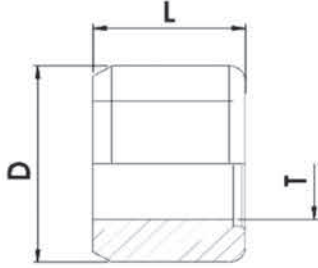

STOK KODU	DİŞ ÖLÇÜSÜ T	L	D
TFMSKR10	1/8-28	16	15
TFMSKR13	1/4-19	17	22
TFMSKR17	3/8-19	19	26
TFMSKR21	1/2-14	25	32
TFMSKR26	3/4-14	26	40
TFMSKR33	1"-11	27	45
TFMSKR42	1"-1/4-11	29	55
TFMSKR48	1"-1/2-11	31	60
TFMSKR60	2"-11	33	80

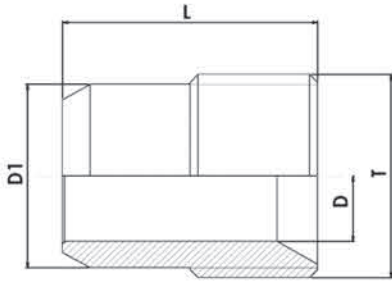

STOK KODU	DIŞ ÖLÇÜSÜ T	L	D	D1
TFGEKR10	1/8-28	23	4	8,4
TFGEKR13	1/4-19	25	5	11,6
TFGEKR17	3/8-19	27	8	14,7
TFGEKR21	1/2-14	30	11	18,5
TFGEKR26	3/4-14	32	17	23,9
TFGEKR33	1"-11	35	22	29,7
TFGEKR42	1"1/4-11	40	29	38,8
TFGEKR48	1"1/2-11	44	33	44,7

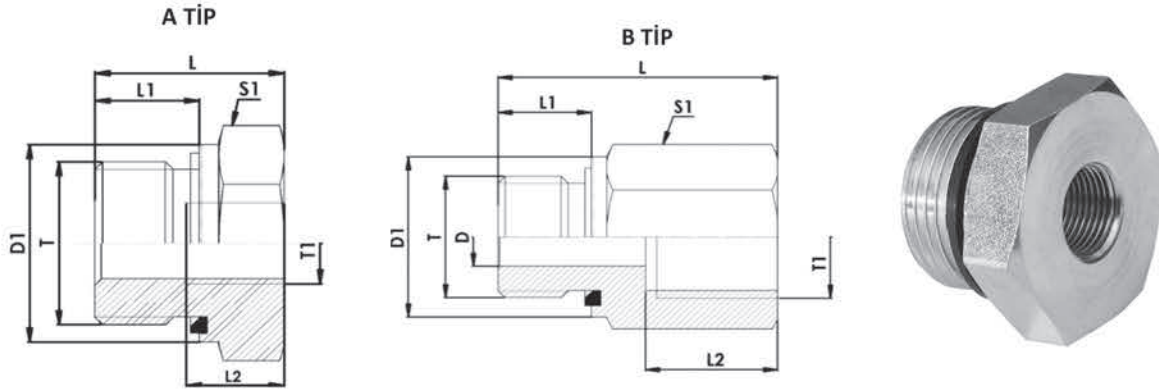

BSP REDÜKSİYON PFX A TİP

STOK KODU	DİŞ ÖLÇÜSÜ T	DİŞ ÖLÇÜSÜ T1	D1	L	L1	L2	S1
TFRKR17R10P	3/8-19	1/8-28	22	22,5	12	8	22
TFRKR21R10P	1/2-14	1/8-28	27	24	14	8	27
TFRKR21R13P	1/2-14	1/4-19	27	24	14	12	27
TFRKR26R13P	3/4-14	1/4-19	32	26	16	12	32
TFRKR26R17P	3/4-14	3/8-19	32	26	16	12	32
TFRKR33R21P	1"-11	3/8-19	40	29	18	12	41
TFRKR33R21P	1"-11	1/2-14	40	29	18	14	41
TFRKR42R17P	1" 1/4-11	1/2-14	50	32	20	14	50
TFRKR42R26P	1" 1/4-11	3/4-14	50	32	20	16	50
TFRKR48R26P	1" 1/2-11	3/4-14	55	35	22	16	55
TFRKR48R33P	1" 1/2-11	1"-11	55	36	22	18	55

BSP REDÜKSİYON PFX B TİP

STOK KODU	DİŞ ÖLÇÜSÜ T	DİŞ ÖLÇÜSÜ T1	D	D1	L	L1	L2	S1
TFRUR13R10P	1/4-19	1/8-28	5	19	29	12	12	19
TFRUR17R13P	3/8-19	1/4-19	8	22	36	12	17	22
TFRUR21R17P	1/2-14	3/8-19	12	27	37	14	17	27
TFRUR26R21P	3/4-14	1/2-14	16	32	43	16	20	32
TFRUR33R26P	1"-11	3/4-14	20	40	49	18	22	41
TFRUR33R48P	1"-11	1" 1/2-11	20	40	59	18	28,5	60
TFRUR48R42P	1" 1/2-11	1" 1/4-11	32	55	58	22	26,5	55

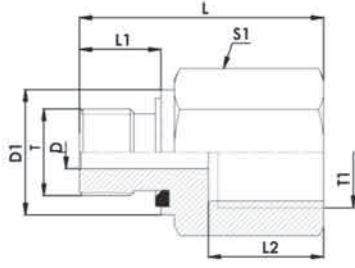

STOK KODU	DIŞ ÖLÇÜSÜ T	DIŞ ÖLÇÜSÜ T1	D	D1	L	L1	L2	S1
TFRUR10R13P	1/8-28	1/4-19	4	14	31	8	17	19
TFRUR10R17P	1/8-28	3/8-19	4	14	32	8	17	24
TFRUR13R17P	1/4-19	3/8-19	5	19	36	12	17	24
TFRUR13R21P	1/4-19	1/2-14	5	19	40	12	20	30
TFRUR17R21P	3/8-19	1/2-14	8	22	41	12	20	30
TFRUR17R26P	3/8-19	3/4-14	8	22	44	12	22	36
TFRUR21R26P	1/2-14	3/4-14	12	27	46	14	22	36
TFRUR21R33P	1/2-14	1"-11	12	27	49	14	24,5	41
TFRUR26R33P	3/4-14	1"-11	16	32	51	16	24,5	41
TFRUR26R42P	3/4-14	1" 1/4-11	16	32	55	16	26,5	55
TFRUR26R48P	3/4-14	1" 1/2-11	16	32	57	16	28,5	60
TFRUR33R42P	1"-11	1" 1/4-11	20	40	57	18	26,5	55
TFRUR33R48P	1"-11	1" 1/2-11	20	40	59	18	28,5	60
TFRUR42R48P	1" 1/4-11	1" 1/2-11	25	50	60	20	28,5	60

BSP UZATMA RAKORU PFX - RI-ED REDUCING ADAPTER

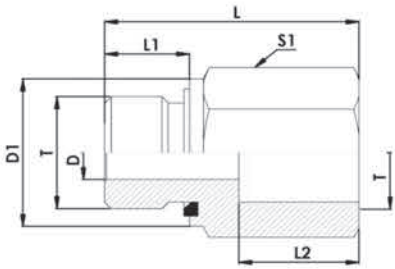

STOK KODU	DIŞ ÖLÇÜSÜ T	D	D1	L	L1	L2	S1
TFRUR10R10P	1/8-28	4	14	25	8	12	14
TFRUR13R13P	1/4-19	5	19	35	12	17	19
TFRUR17R17P	3/8-19	8	22	36	12	17	22
TFRUR21R21P	1/2-14	12	27	43	14	20	27
TFRUR26R26P	3/4-14	16	32	48	16	22	36
TFRUR33R33P	1"-11	20	40	55	18	24,5	41

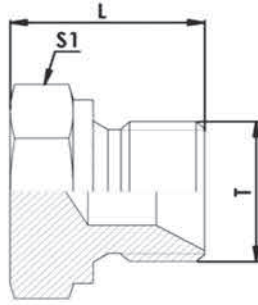

STOK KODU	DIŞ ÖLÇÜSÜ T	L	S1
TFKTER10	1/8-28	14	14
TFKTER13	1/4-19	19	19
TFKTER17	3/8-19	21	22
TFKTER21	1/2-14	24	27
TFKTER26	3/4-14	27	32
TFKTER33	1"-11	30	41
TFKTER42	1"1/4-11	39	50
TFKTER48	1"1/2-11	43	55
TFKTER60	2"-11	48	70

BSP SOMUNLU KÖR TAPA (60°) - HEX PIPE CAP

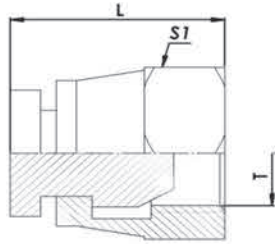

STOK KODU	DIŞ ÖLÇÜSÜ T	L	S1
TFKTBR10	1/8-28	15	14
TFKTBR13	1/4-19	20	19
TFKTBR17	3/8-19	22	22
TFKTBR21	1/2-14	22	27
TFKTBR26	3/4-14	26	32
TFKTBR33	1"-11	30	41
TFKTBR42	1"1/4-11	34	50

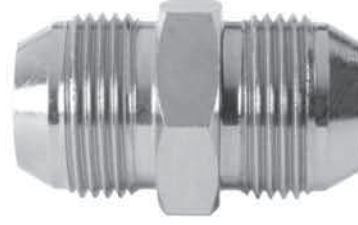
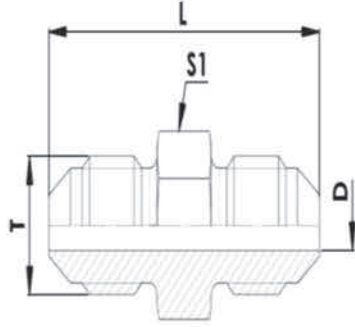

STOK KODU	DİŞ ÖLÇÜSÜ T	D	L	S1
TFGNW11	7/16-20	4	35	14
TFGNW13	1/2-20	6	35	14
TFGNW14	9/16-18	8	36	17
TFGNW16	5/8-18	8	40	17
TFGNW19	3/4-16	10	41	19
TFGNW22	7/8-14	12	48	24
TFGNW27	1"1/16-12	16	55	27
TFGNW33	1"5/16-12	22	57	36
TFGNW41	1"5/8-12	28	62	46
TFGNW47	1"7/8-12	33	70	50
TFGNW64	2"1/2-12	45	87	65

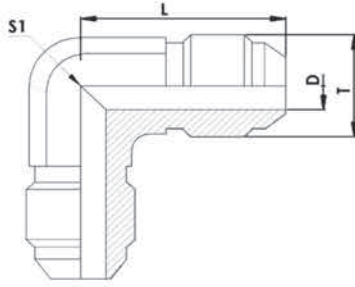

STOK KODU	DIŞ ÖLÇÜSÜ T	D	L	S1
TFDIW11	7/16-20	4	23	12
TFDIW13	1/2-20	6	24	12
TFDIW14	9/16-18	8	27	14
TFDIW16	5/8-18	8	27	17
TFDIW19	3/4-16	10	32	19
TFDIW22	7/8-14	12	37	22
TFDIW27	1"1/16-12	16	42	27
TFDIW33	1"5/16-12	22	46	36
TFDIW41	1"5/8-12	28	52	41
TFDIW47	1"7/8-12	33	59	50

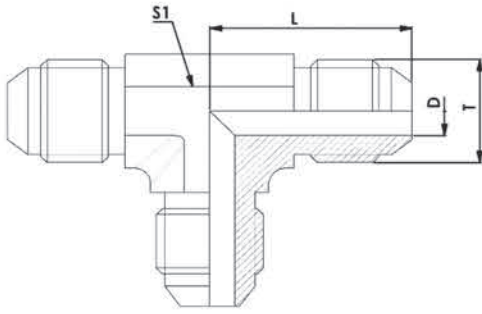

STOK KODU	DIŞ ÖLÇÜSÜ T	D	L	S1
TFTEW11	7/16-20	4	23	12
TFTEW13	1/2-20	6	24	14
TFTEW14	9/16-18	8	27	14
TFTEW16	5/8-18	8	27	17
TFTEW19	3/4-16	10	32	19
TFTEW22	7/8-14	12	37	22
TFTEW27	1"1/16-12	16	42	27
TFTEW33	1"5/16-12	22	46	32
TFTEW41	1"5/8-12	28	52	41
TFTEW47	1"7/8-12	33	59	50

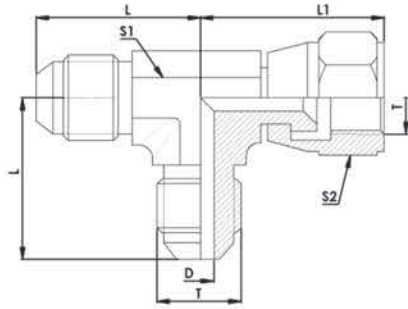

STOK KODU	DIŞ ÖLÇÜSÜ T	D	L	L1	S1	S2
TFTEFW11	7/16-20	4	23	26	12	17
TFTEFW13	1/2-20	6	24	27	14	17
TFTEFW14	9/16-18	8	27	32	14	19
TFTEFW16	5/8-18	8	27	32	17	22
TFTEFW19	3/4-16	10	32	35	19	22
TFTEFW22	7/8-14	12	37	41	22	27
TFTEFW27	1"1/16-12	16	42	44	27	32
TFTEFW33	1"5/16-12	22	46	51	32	38
TFTEFW41	1"5/8-12	28	52	59	41	50
TFTEFW47	1"7/8-12	33	59	66	50	60

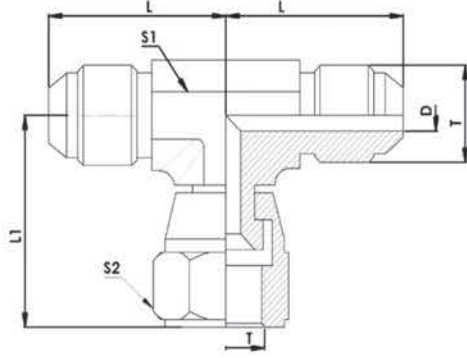

STOK KODU	DIŞ ÖLÇÜSÜ T	D	L	L1	S1	S2
TFTEGW11	7/16-20	4	23	26	12	17
TFTEGW13	1/2-20	6	24	27	14	17
TFTEGW14	9/16-18	8	27	32	14	19
TFTEGW16	5/8-18	8	27	32	17	22
TFTEGW19	3/4-16	10	32	35	19	22
TFTEGW22	7/8-14	12	37	41	22	27
TFTEGW27	1"1/16-12	16	42	44	27	32
TFTEGW33	1"5/16-12	22	46	51	32	38
TFTEGW41	1"5/8-12	28	52	59	41	50
TFTEGW47	1"7/8-12	33	59	66	50	60

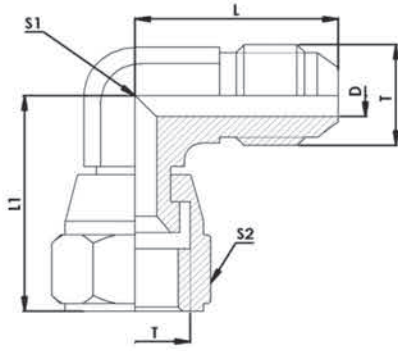

STOK KODU	Dış Ölçüsü T	D	L	L1	S1	S2
TFDITW11	7/16-20	4	23	26	12	17
TFDITW13	1/2-20	6	24	27	12	17
TFDITW14	9/16-18	8	27	32	14	19
TFDITW16	5/8-18	8	27	32	17	22
TFDITW19	3/4-16	10	32	35	19	22
TFDITW22	7/8-14	12	37	41	22	27
TFDITW27	1"1/16-12	16	42	44	27	32
TFDITW33	1"5/16-12	22	46	51	36	38
TFDITW41	1"5/8-12	28	52	59	41	50
TFDITW47	1"7/8-12	33	59	66	50	60

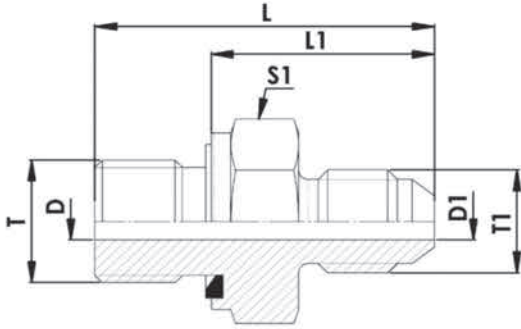

STOK KODU	DİŞ ÖLÇÜSÜ T	DİŞ ÖLÇÜSÜ T1	D	D1	L	L1	S1
TFGER10W11P	1/8-28	7/16-20	4	4	30	22	14
TFGER13W11P	1/4-19	7/16-20	4	4	35	23	19
TFGER13W13P	1/4-19	1/2-20	6	6	35	23	19
TFGER13W14P	1/4-19	9/16-18	6	8	35	23	19
TFGER13W16P	1/4-19	5/8-18	6	8	37	25	19
TFGER13W19P	1/4-19	3/4-16	6	10	38	26	19
TFGER17W11P	3/8-19	7/16-20	4	4	36	24	22
TFGER17W13P	3/8-19	1/2-20	6	6	36	24	22
TFGER17W14P	3/8-19	9/16-18	8	8	36	24	22
TFGER17W16P	3/8-19	5/8-18	8	8	38	26	22
TFGER17W19P	3/8-19	3/4-16	10	10	39	27	22
TFGER17W22P	3/8-19	7/8-14	9	12	42	30	24
TFGER21W13P	1/2-14	1/2-20	6	6	39	25	27
TFGER21W14P	1/2-14	9/16-18	8	8	39	25	27
TFGER21W16P	1/2-14	5/8-18	8	8	41	27	27
TFGER21W19P	1/2-14	3/4-16	10	10	43	29	27
TFGER21W22P	1/2-14	7/8-14	12	12	45	31	27
TFGER21W27P	1/2-14	1"1/16-12	16	16	48	34	27
TFGER26W19P	3/4-14	3/4-16	10	10	46	30	32
TFGER26W22P	3/4-14	7/8-14	12	12	48	32	32
TFGER26W27P	3/4-14	1"1/16-12	16	16	51	35	32
TFGER26W33P	3/4-14	1"5/16-12	16	22	52	36	36
TFGER33W27P	1"-11	1"1/16-12	16	16	55	37	41
TFGER33W33P	1"-11	1"5/16-12	22	22	56	38	41
TFGER42W33P	1"1/4-11	1"5/16-12	22	22	55	39	50
TFGER48W47P	1"1/2-11	1"7/8-12	33	33	61	45	55

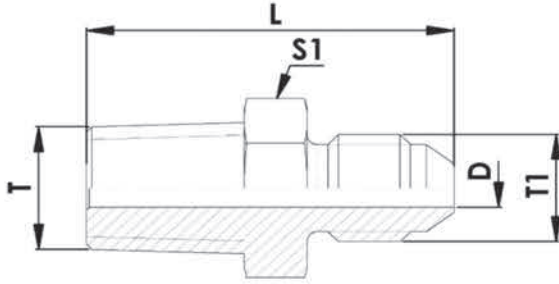

STOK KODU	DİŞ ÖLÇÜSÜ T	DİŞ ÖLÇÜSÜ T1	D	L	S1
TFGEN10W11	1/8-28 BSPT	7/16-20	4	31	13
TFGEN13W11	1/4-19 BSPT	7/16-20	4	36	14
TFGEN13W13	1/4-19 BSPT	1/2-20	6	36	14
TFGEN13W14	1/4-19 BSPT	9/16-18	8	36	17
TFGEN13W16	1/4-19 BSPT	5/8-18	8	38	17
TFGEN13W19	1/4-19 BSPT	3/4-16	8	39	19
TFGEN17W14	3/8-19 BSPT	9/16-18	8	36	19
TFGEN17W16	3/8-19 BSPT	5/8-18	8	38	19
TFGEN17W19	3/8-19 BSPT	3/4-16	10	39	19
TFGEN21W14	1/2-14 BSPT	9/16-18	8	43	22
TFGEN21W16	1/2-14 BSPT	5/8-18	8	44	22
TFGEN21W19	1/2-14 BSPT	3/4-16	10	46	22
TFGEN21W22	1/2-14 BSPT	7/8-14	12	48	24
TFGEN26W27	3/4-14 BSPT	1"1/16-12	16	52	27
TFGEN33W33	1"-11 BSPT	1"5/16-12	22	58	36
TFGEN42W41	1"1/4-11 BSPT	1"5/8-12	28	62	46
TFGEN48W43	1"1/2-11 BSPT	1"7/8-12	33	68	50

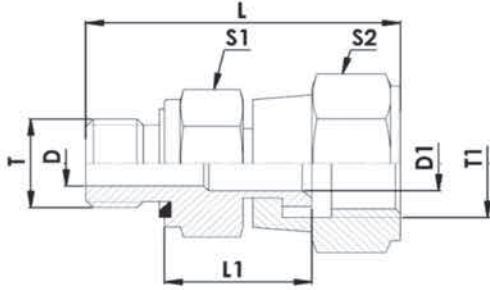

STOK KODU	DIŞ ÖLÇÜSÜ T	DIŞ ÖLÇÜSÜ T1	D	D1	L	L1	S1	S2
TFGER10TW11P	1/8-28	7/16-20	4	4	31	15	14	17
TFGER13TW11P	1/4-19	7/16-20	4	4	36	16	19	17
TFGER13TW13P	1/4-19	1/2-20	6	6	40	18	19	17
TFGER13TW14P	1/4-19	9/16-18	6,5	6,5	40	18	19	19
TFGER17TW14P	3/8-19	9/16-18	8	6,5	41	19	22	19
TFGER17TW16P	3/8-19	5/8-18	8	7	41	19	22	22
TFGER17TW19P	3/8-19	3/4-16	8	9	44	21	22	22
TFGER21TW14P	1/2-14	9/16-18	11	6,5	46	20	27	19
TFGER21TW16P	1/2-14	5/8-18	11	7	46	20	27	22
TFGER21TW19P	1/2-14	3/4-16	11	9	48	23	27	22
TFGER21TW22P	1/2-14	7/8-14	12	12	50	23	27	27
TFGER26TW22P	3/4-14	7/8-14	17	12	55	23	32	27
TFGER26TW27P	3/4-14	1"1/16-12	17	15	54	24	32	32
TFGER33TW27P	1"-11	1"1/16-12	22	15	62	24	41	32
TFGER33TW33P	1"-11	1"5/16-12	22	21	60	27	41	38
TFGER42TW41P	1"1/4-11	1"5/8-12	28	28	68	32	50	60
TFGER48TW43P	1"1/2-11	1"7/8-12	33	33	85	36	55	60

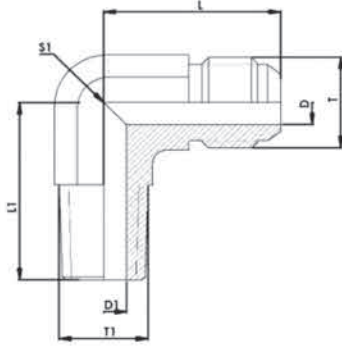

STOK KODU	DİŞ ÖLÇÜSÜ T1	DİŞ ÖLÇÜSÜ T	D	D1	L	L1	S1
TFDIN10W11	1/8-28 BSPT	7/16-20	4	5	23	20	12
TFDIN10W13	1/8-28 BSPT	1/2-20	6	5	24	20	12
TFDIN13W14	1/4-19 BSPT	9/16-18	8	8	27	28	14
TFDIN13W16	1/4-19 BSPT	5/8-18	8	8	27	28	17
TFDIN13W19	1/4-19 BSPT	3/4-16	10	7	32	31	19
TFDIN17W13	3/8-19 BSPT	1/2-20	6	8	29	31	19
TFDIN17W14	3/8-19 BSPT	9/16-18	8	8	29	31	19
TFDIN17W16	3/8-19 BSPT	5/8-18	8	8	29	31	19
TFDIN17W19	3/8-19 BSPT	3/4-16	10	8	32	31	19
TFDIN21W14	1/2-14 BSPT	9/16-18	8	11	31	37	22
TFDIN21W16	1/2-14 BSPT	5/8-18	8	11	31	37	22
TFDIN21W19	1/2-14 BSPT	3/4-16	10	11	34	37	22
TFDIN21W22	1/2-14 BSPT	7/8-14	12	11	37	37	22
TFDIN21W27	1/2-14 BSPT	1"1/16-12	16	11	40	40	27
TFDIN26W19	3/4-14 BSPT	3/4-16	10	16	36	40	27
TFDIN26W22	3/4-14 BSPT	7/8-14	12	16	39	40	27
TFDIN26W27	3/4-14 BSPT	1"1/16-12	16	16	42	40	27
TFDIN33W27	1"-11 BSPT	1"1/16-12	16	22	45	50	36
TFDIN33W33	1"-11 BSPT	1"5/16-12	22	22	46	50	36
TFDIN42W41	1"1/4-11 BSPT	1"5/8-12	28	32	52	61	41
TFDIN48W43	1"1/2-11 BSPT	1"7/8-12	33	38	59	67	50

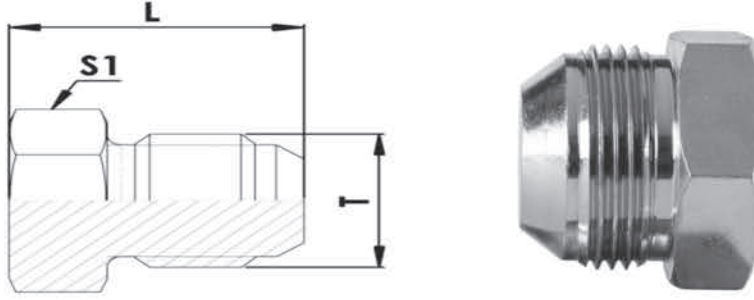

STOK KOD	DİŞ ÖLÇÜSÜ T	L	S1
TFKTEW11	7/16-20	20	14
TFKTEW13	1/2-20	20	14
TFKTEW14	9/16-18	21	17
TFKTEW16	5/8-18	23	17
TFKTEW19	3/4-16	24	19
TFKTEW22	7/8-14	28	24
TFKTEW27	1"1/16-12	33	27
TFKTEW33	1"5/16-12	34	36
TFKTEW41	1"5/8-12	37	46
TFKTEW43	1"7/8-12	42	50

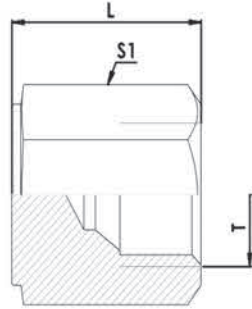

STOK KODU	DIŐ ÖLÇÜSÜ T	L	S1
TFKTUW11	7/16-20	17	14
TFKTUW13	1/2-20	20	17
TFKTUW14	9/16-18	21	19
TFKTUW16	5/8-18	21	22
TFKTUW19	3/4-16	24	22
TFKTUW22	7/8-14	27	27
TFKTUW27	1"1/16-12	32	32
TFKTUW33	1"5/16-12	33	41
TFKTUW41	1"5/8-12	35	50
TFKTUW43	1"7/8-12	43	60

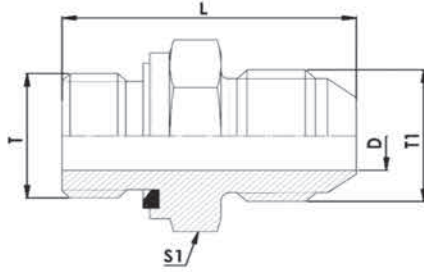

STOK KODU	DİŞ ÖLÇÜSÜ T	DİŞ ÖLÇÜSÜ T1	D	L	S1
TFGEM16W16P	M16X1,5	5/8-18	7	36	22
TFGEM16W19P	M16X1,5	3/4-16	10	37	22
TFGEM18W19P	M18X1,5	3/4-16	10	37	24
TFGEM22W16P	M22X1,5	5/8-18	7	40	27
TFGEM22W19P	M22X1,5	3/4-16	10	41	27

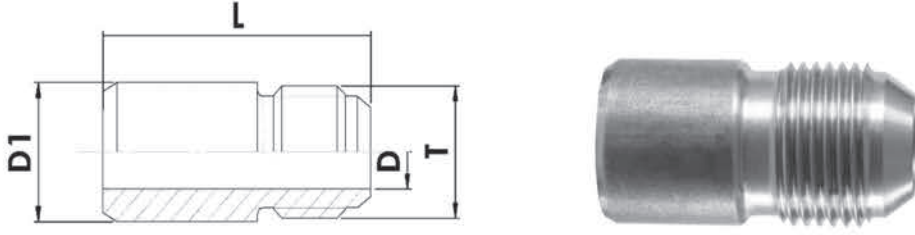

STOK KODU	DIŞ ÖLÇÜSÜ T	L	D	D1
TFGEKW13	1/2-20	29	6	13
TFGEKW14	9/16-18	33	7	15
TFGEKW16	5/8-18	35	7	16
TFGEKW19	3/4-16	40	10	20
TFGEKW22	7/8-14	40	12	23
TFGEKW27	1"1/16-12	50	15	27
TFGEKW33	1"5/16-12	55	21	34

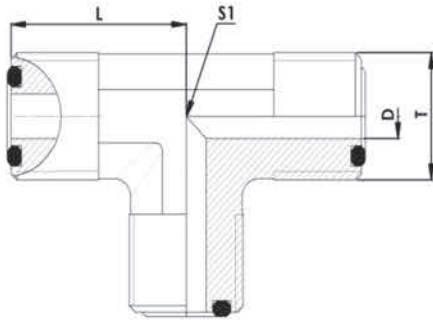

STOK KODU	DIŞ ÖLÇÜSÜ T	D	L	S1
TFTEO14	9/16-18	5	22	14
TFTEO17	11/16-16	7	25	19
TFTEO21	13/16-16	10	28	19
TFTEO25	1"-14	13	33	27
TFTEO30	1"3/16-12	16	37	32
TFTEO37	1"7/16-12	21	42	36
TFTEO43	1"11/16-12	26	45	41

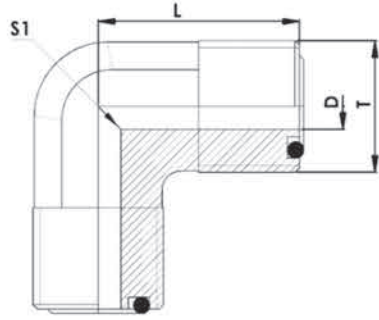

STOK KODU	DİŞ ÖLÇÜSÜ T	D	L	S1
TFDIO14	9/16-18	5	22	14
TFDIO17	11/16-16	7	25	19
TFDIO21	13/16-16	10	28	19
TFDIO25	1"-14	13	33	27
TFDIO30	1"3/16-12	16	37	32
TFDIO37	1"-7/16-12	21	42	36
TFDIO43	1"11/16-12	26	45	41

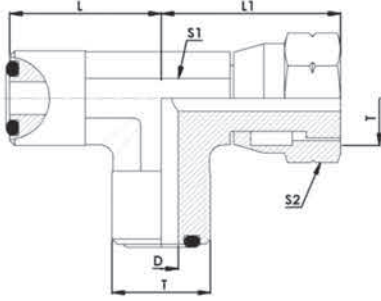

STOK KODU	DIŞ ÖLÇÜSÜ T	D	L	L1	S1	S2
TFTEFO14	9/16-18	5	22	26	14	17
TFTEFO17	11/16-16	7	25	29	19	22
TFTEFO21	13/16-16	10	28	38	19	24
TFTEFO25	1"-14	13	33	41	27	30
TFTEFO30	1"3/16-12	16	37	46	32	36
TFTEFO37	1"7/16-12	21	42	53	36	41
TFTEFO43	1"11/16-12	26	45	58	41	50

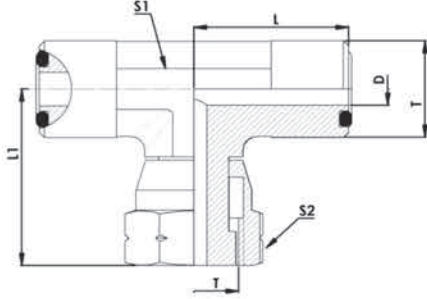

STOK KOD	DIŞ ÖLÇÜSÜ T	D	L	L1	S1	S2
TFTEGO14	9/16-18	5	22	26	14	17
TFTEGO17	11/16-16	7	25	29	19	22
TFTEGO21	13/16-16	10	28	38	19	24
TFTEGO25	1"-14	13	33	41	27	30
TFTEGO30	1"3/16-12	16	37	46	32	36
TFTEGO37	1"7/16-12	21	42	53	36	41
TFTEGO43	1"11/16-12	26	45	58	41	50

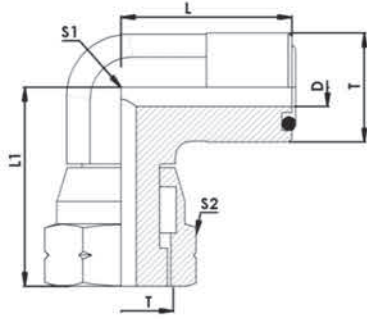

STOK KOD	DİŞ ÖLÇÜSÜ T	D	L	L1	S1	S2
TFDIDO14	9/16-18	5	22	26	14	17
TFDIDO17	11/16-16	7	25	29	19	22
TFDIDO21	13/16-16	10	28	38	19	24
TFDIDO25	1"-14	13	33	41	27	30
TFDIDO30	1"3/16-12	16	37	46	32	36
TFDIDO37	1"7/16-12	21	42	53	36	41
TFDIDO43	1"11/16-12	26	45	58	41	50

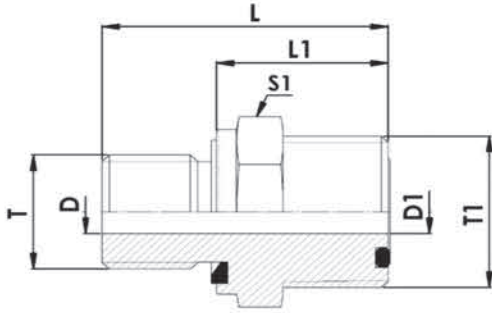

STOK KODU	Diş ölçüsü T	Diş ölçüsü T1	D	D1	L	L1	S1
TFGER13O14P	1/4-19	9/16-18	5	5	30	18	19
TFGER13O17P	1/4-19	11/16-16	5	5	31	20	19
TFGER17O17P	3/8-19	11/16-16	7	7	33	21	22
TFGER17O21P	3/8-19	13/16-16	8	8	35	23	22
TFGER21O21P	1/2-14	13/16-16	10	10	38	24	27
TFGER21O25P	1/2-14	1"-14	11	11	41	27	27
TFGER26O30P	3/4-14	1"3/16-12	16	16	46	30	32
TFGER26O37P	3/4-14	1"7/16-12	16	16	52	36	41
TFGER33O37P	1"-11	1"-7/16-12	21	21	50	32	41
TFGER33O42P	1"-11	1"11/16-12	22	22	57	39	46
TFGER42O37P	1"1/4-11	1"7/16-12	21	21	54	34	50
TFGER42O43P	1"1/4-11	1"11/16-12	25	25	54	34	50

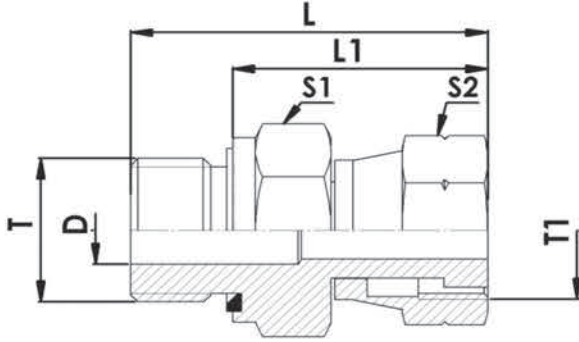

STOK KOD	DIŞ ÖLÇÜSÜ T	DIŞ ÖLÇÜSÜ T1	D	L	L1	S1	S2
TFGER13TO14P	1/4-19	9/16-18	4	38	26	19	17
TFGER13TO17P	1/4-19	11/16-16	5	40	28	19	22
TFGER17TO17P	3/8-19	11/16-16	7	40	28	22	22
TFGER17TO21P	3/8-19	13/16-16	8	47	35	22	24
TFGER21TO21P	1/2-14	13/16-16	9	49	35	27	24
TFGER21TO25P	1/2-14	1"-14	10	52	38	27	30
TFGER26TO30P	3/4-14	1"-3/16-12	14	57	41	32	36
TFGER26TO37P	3/4-14	1"-7/16-12	16	59	43	32	41
TFGER33TO37P	1"-11	1"-7/16-12	20	67	49	41	41
TFGER40TO43P	1"1/4-11	1"-11/16-12	25	69	49	50	50

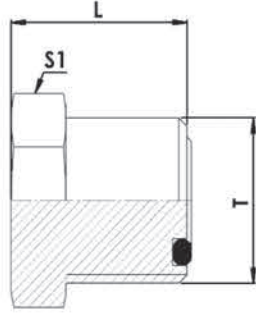

STOK KODU	DİŞ ÖLÇÜSÜ T	L	S1
TFKTE014	9/16-18	17	16
TFKTE017	11/16-16	19	19
TFKTE021	13/16-16	22	22
TFKTE025	1"-14	26	27
TFKTE030	1" 3/16-12	27	32
TFKTE037	1" 7/16-12	28	38
TFKTE043	1"11/16-12	28	45

ORFS SOMUNLU TAPALAR - HEX CAP

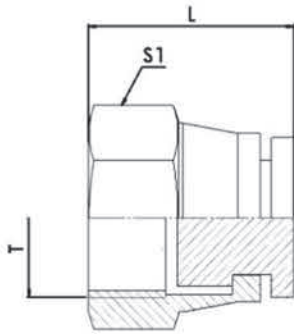

STOK KODU	DİŞ ÖLÇÜSÜ T	L	S1
TFKTBO14	9/16-18	18	19
TFKTBO17	11/16-16	20	22
TFKTBO21	13/16-16	25	24
TFKTBO25	1"-14	28	30
TFKTBO30	1" 3/16-12	31	36
TFKTBO37	1" 7/16-12	33	41
TFKTBO43	1"11/16-12	35	50

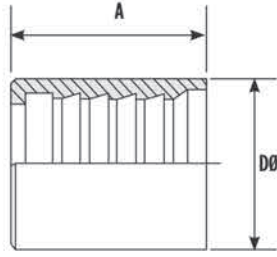

MALZEME KODU Part Ref.	HORTUM İÇ ÇAPI Hose Bore		BOYUT ÖLÇÜLERİ mm Dimensions in mm	
	DN	INCH	D	A
THSBH5	5	3/16	18.0	25.0
THSBH6	6	1/4	20.0	32.0
THSBH8	8	5/16	22.0	32.5
THSBH10	10	3/8	25.0	35.0
THSBH12	12	1/2	28.0	35.0
THSBH16	16	5/8	32.0	43.0
THSBH19	19	3/4	38.0	47.0
THSBH25	25	1	45.0	52.0
THSBH31	31	1 1/4	56.0	70.0
THSBH38	38	1 1/2	62.0	75.0
THSBH50	50	2	75.0	70.0
THSBH63	63	2 1/2	88.0	70.0
THSBH76	76	3	100.5	80.5

2SN SOYMASIZ HORTUM SOKETLERİ | FERRULE

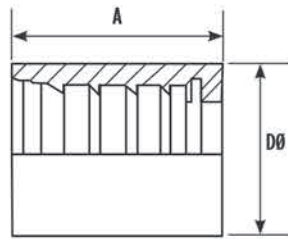

MALZEME KODU Part Ref.	HORTUM İÇ ÇAPI Hose Bore		BOYUT ÖLÇÜLERİ mm Dimensions in mm	
	DN	INCH	D	A
THSSH6	6	1/4	20.0	32.0
THSSH8	8	5/16	22.0	32.0
THSSH10	10	3/8	25.0	35.0
THSSH12	12	1/2	29.0	35.0
THSSH16	16	5/8	34.0	36.0
THSSH19	19	3/4	38.0	53.0
THSSH25	25	1	45.0	56.0

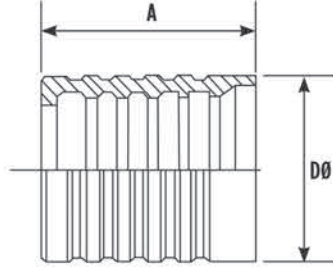

MALZEME KODU Part Ref.	HORTUM İÇ ÇAPI Hose Bore		BOYUT ÖLÇÜLERİ mm Dimensions in mm	
	DN	INCH	D	A
THSDH6	6	1/4	22.0	32.0
THSDH10	10	3/8	26.0	33.0
THSDH12	12	1/2	30.0	38.0
THSDH16	16	5/8	34.0	45.0
THSDH19	19	3/4	38.0	52.0
THSDH25	25	1	45.0	64.0
THSDH31	31	1 1/4	56.0	70.0
THSDH38	38	1 1/2	62.0	75.0
THSDH50	50	2	75.0	70.0

R13 - R15 INTERLOCK HORTUM SOKETLERİ | FERRULE

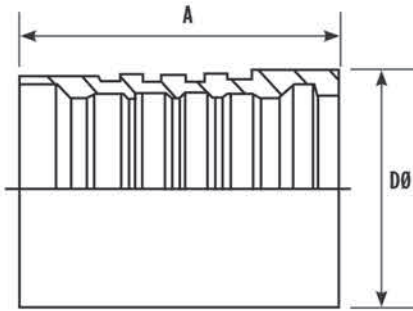

MALZEME KODU Part Ref.	HORTUM İÇ ÇAPI Hose Bore		BOYUT ÖLÇÜLERİ mm Dimensions in mm	
	DN	INCH	D	A
THSOH19	19	3/4	40.0	53.0
THSOH25	25	1	49.0	66.0
THSOH31	31	1 1/4	60.0	89.0
THSOH38	38	1 1/2	69.0	100.0
THSOH51	51	2	87.0	108.0

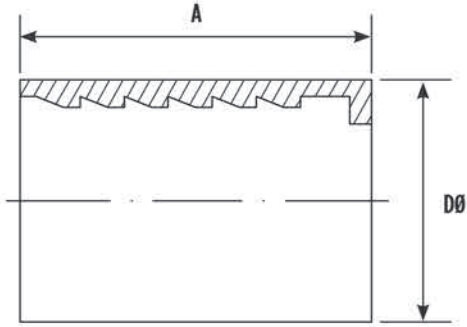

MALZEME KODU Part Ref.	HORTUM İÇ ÇAPI Hose Bore		BOYUT ÖLÇÜLERİ mm Dimensions in mm	
	DN	INCH	D	A
THSTH5	5	3/16	16	25
THSTH6	6	1/4	17	30
THSTH8	8	5/16	20	32
THSTH10	10	3/8	22	33
THSTH12	12	1/2	25	36
THSTH16	16	5/8	28	36
THSTH19	19	3/4	32	42

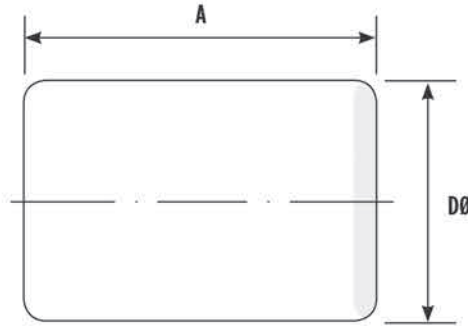

MALZEME KODU Part Ref.	HORTUM İÇ ÇAPI Hose Bore		BOYUT ÖLÇÜLERİ mm Dimensions in mm	
	DN	INCH	D	A
THSFH5	5	3/16	14.0	30.0
THSFH6	6	1/4	14.0	30.0
THSFH8	8	5/16	16.0	30.0
THSFH10	10	3/8	19.0	31.0
THSFH12	12	1/2	24.0	34.0
THSFH16	16	5/8	26.0	37.0
TFSFH19	19	3/4	30.0	42.5

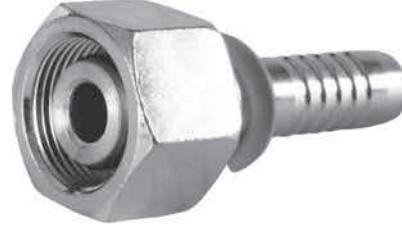
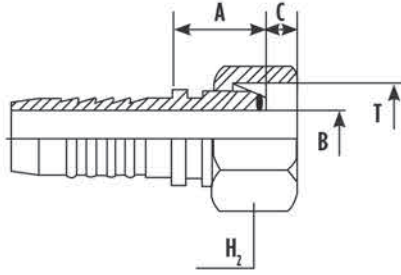

MALZEME KODU Part Ref.	HORTUM İÇ ÇAPI Hose Bore		DİŞ ÖLÇÜSÜ Thread	BOYUT ÖLÇÜLERİ mm Dimensions in mm				
	DN	INCH		T	B	A	C	BORU Ø
THDUU06LH5	5	3/16	M 12x1.5	3.0	20.3	1.7	6	14
THDUU06LH6	6	1/4	M 12x1.5	4.0	21.8	2.2	6	17
THDUU08LH6	6	1/4	M 14x1.5	4.0	24.5	1.7	8	17
THDUU10LH6	6	1/4	M 16x1.5	4.0	22.7	2.1	10	19
THDUU12LH6	6	1/4	M 18x1.5	4.0	24.5	1.5	12	22
THDUU08LH8	8	5/16	M 14x1.5	5.0	23.2	1.7	8	17
THDUU10LH8	8	5/16	M 16x1.5	5.0	23.7	2.1	10	19
THDUU12LH8	8	5/16	M 18x1.5	5.0	24.7	2.3	12	22
THDUU10LH10	10	3/8	M 16x1.5	6.5	20.0	3.0	10	22
THDUU12LH10	12	3/8	M 18x1.5	6.5	25.5	1.5	12	22
THDUU15LH10	10	3/8	M 22x1.5	6.5	27.0	2.3	15	27
THDUU12LH12	12	1/2	M 18x1.5	9.0	29.2	1.3	12	22
THDUU15LH12	12	1/2	M 22x1.5	9.0	25.5	2.3	15	27
THDUU18LH12	12	1/2	M 26x1.5	9.0	30.0	2.5	18	32
THDUU18LH16	16	5/8	M 26x1.5	11.5	32.0	2.5	18	32
THDUU22LH16	16	5/8	M 30x2	11.5	32.0	3.6	22	36
THDUU22LH19	19	3/4	M 30x2	14.5	30.5	3.6	22	36
THDUU28LH19	19	3/4	M 36x2	14.5	38.5	3.8	28	41
THDUU28LH25	25	1	M 36x2	18.5	40.0	3.8	28	41
THDUU35LH25	25	1	M 45x2	18.5	40.0	4.0	35	50
THDUU35LH31	31	1 1/4	M 45x2	24.5	45.2	5.1	35	50
THDUU42LH31	31	1 1/4	M 52x2	24.5	47.5	5.1	42	60
THDUU42LH38	38	1 1/2	M 52x2	29.5	46.5	5.1	42	60

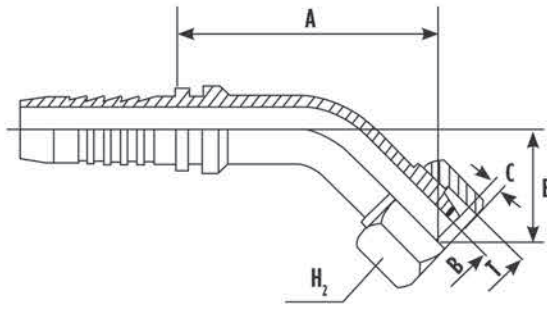

MALZEME KODU Part Ref.	HORTUM İÇ ÇAPI Hose Bore		DİŞ ÖLÇÜSÜ Thread	BOYUT ÖLÇÜLERİ mm Dimensions in mm					
	DN	INCH		T	B	A	C	E	BORU Ø
THKIU06LH5	5	3/16	M 12x1.5	3.0	41.0	1.7	24.0	6	14
THKIU06LH6	6	1/4	M 12x1.5	4.0	46.0	2.2	26.0	6	17
THKIU08LH6	6	1/4	M 14x1.5	4.0	42.5	1.7	20.0	8	17
THKIU10LH6	6	1/4	M 16x1.5	4.0	43.5	2.1	23.0	10	19
THKIU12LH6	6	1/4	M 18x1.5	4.0	45.5	1.5	22.5	12	22
THKIU08LH8	8	5/16	M 14x1.5	5.0	44.5	1.7	20.0	8	17
THKIU10LH8	8	5/16	M 16x1.5	5.0	44.5	1.3	23.0	10	19
THKIU12LH8	8	5/16	M 18x1.5	5.0	46.0	2.3	19.5	12	22
THKIU10LH10	10	3/8	M 16x1.5	6.5	51.0	3.0	23.5	10	22
THKIU12LH10	12	3/8	M 18x1.5	6.5	45.0	1.5	20.0	12	22
THKIU15LH10	10	3/8	M 22x1.5	6.5	57.0	2.3	28.0	15	27
THKIU12LH12	12	1/2	M 18x1.5	9.0	70.0	1.3	32.0	12	22
THKIU15LH12	12	1/2	M 22x1.5	9.0	60.0	2.3	25.0	15	27
THKIU18LH12	12	1/2	M 26x1.5	9.0	63.0	2.5	27.0	18	32
THKIU18LH16	16	5/8	M 26x1.5	11.5	80.0	2.5	27.0	18	32
THKIU22LH16	16	5/8	M 30x2	11.5	78.0	3.6	29.0	22	36
THKIU22LH19	19	3/4	M 30x2	14.5	86.0	3.6	24.0	22	36
THKIU28LH19	19	3/4	M 36x2	14.5	82.0	3.8	37.5	28	41
THKIU28LH25	25	1	M 36x2	18.5	104.0	3.8	41.5	28	41
THKIU35LH25	25	1	M 45x2	18.5	101.0	4.0	40.0	35	50
THKIU35LH31	31	1 1/4	M 45x2	24.5	115.0	5.1	43.0	35	50
THKIU42LH31	31	1 1/4	M 52x2	24.5	119.5	5.1	53.5	42	60
THKIU42LH38	38	1 1/2	M 52x2	29.5	120.0	5.1	54.0	42	60

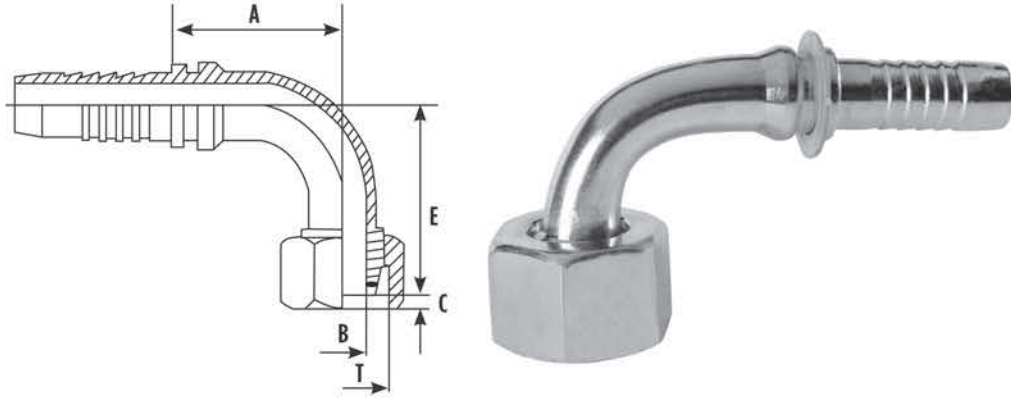

MALZEME KODU Part Ref.	HORTUM İÇ ÇAPI Hose Bore		DİŞ ÖLÇÜSÜ Thread	BOYUT ÖLÇÜLERİ mm Dimensions in mm					
	DN	INCH		T	B	A	C	E	BORU Ø
THDOU06LH5	5	3/16	M 12x1.5	3.0	26.0	1.7	30.0	6	14
THDOU06LH6	6	1/4	M 12x1.5	4.0	28.0	2.2	35.0	6	17
THDOU08LH6	6	1/4	M 14x1.5	4.0	34.0	1.7	32.5	8	17
THDOU10LH6	6	1/4	M 16x1.5	4.0	33.0	2.1	35.0	10	19
THDOU12LH6	6	1/4	M 18x1.5	4.0	33.0	1.5	36.0	12	22
THDOU08LH8	8	5/16	M 14x1.5	5.0	33.0	1.7	33.0	8	17
THDOU10LH8	8	5/16	M 16x1.5	5.0	32.5	1.3	39.5	10	19
THDOU12LH8	8	5/16	M 18x1.5	5.0	32.0	2.3	40.0	12	22
THDOU10LH10	10	3/8	M 16x1.5	6.5	37.5	3.0	42.5	10	22
THDOU12LH10	12	3/8	M 18x1.5	6.5	39.0	1.5	33.0	12	22
THDOU15LH10	10	3/8	M 22x1.5	6.5	39.0	2.3	37.0	15	27
THDOU12LH12	12	1/2	M 18x1.5	9.0	46.0	1.9	49.0	12	22
THDOU15LH12	12	1/2	M 22x1.5	9.0	48.0	2.3	39.0	15	27
THDOU18LH12	12	1/2	M 26x1.5	9.0	45.5	2.5	50.0	18	32
THDOU18LH16	16	5/8	M 26x1.5	11.5	55.0	2.5	55.0	18	32
THDOU22LH16	16	5/8	M 30x2	11.5	53.0	3.6	57.0	22	36
THDOU22LH19	19	3/4	M 30x2	14.5	58.0	3.6	57.0	22	36
THDOU28LH19	19	3/4	M 36x2	14.5	65.0	3.8	68.0	28	41
THDOU28LH25	25	1	M 36x2	18.5	82.0	3.8	71.0	28	41
THDOU35LH25	25	1	M 45x2	18.5	78.0	5.1	72.0	35	50
THDOU35LH31	31	1 1/4	M 45x2	24.5	91.0	5.1	80.0	35	50
THDOU42LH31	31	1 1/4	M 52x2	24.5	87.0	5.1	89.0	42	60
THDOU42LH38	38	1 1/2	M 52x2	29.5	95.0	5.1	99.5	42	60

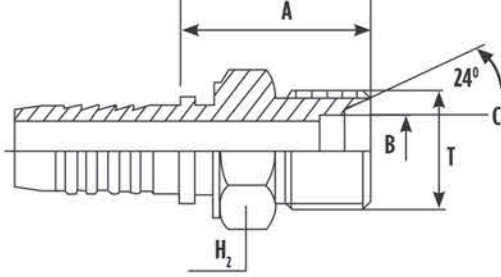

MALZEME KODU Part Ref.	HORTUM İÇ ÇAPI Hose Bore		DİŞ ÖLÇÜSÜ Thread	BOYUT ÖLÇÜLERİ mm Dimensions in mm			
	DN	INCH		T	B	A	C
THED06LH5	5	3/16	M 12x1.5	3.0	20.4	6.0	12
THED06LH6	6	1/4	M 12x1.5	4.0	21.0	6.0	12
THED08LH6	6	1/4	M 14x1.5	4.0	23.5	8.0	14
THED10LH6	6	1/4	M 16x1.5	4.0	25.5	10.0	17
THED12LH6	6	1/4	M 18x1.5	4.0	26.5	12.0	19
THED08LH8	8	5/16	M 14x1.5	5.0	23.5	8.0	14
THED10LH8	8	5/16	M 16x1.5	5.0	25.0	10.0	17
THED12LH8	8	5/16	M 18x1.5	5.0	27.5	12.0	19
THED10LH10	10	3/8	M 16x1.5	6.5	27.0	10.0	17
THED12LH10	12	3/8	M 18x1.5	6.5	27.0	12.0	19
THED15LH10	10	3/8	M 22x1.5	6.5	27.5	15.0	22
THED12LH12	12	1/2	M 18x1.5	9.0	27.0	12.0	19
THED15LH12	12	1/2	M 22x1.5	9.0	32.0	15.0	22
THED18LH12	12	1/2	M 26x1.5	9.0	31.5	18.0	27
THED18LH16	16	5/8	M 26x1.5	11.5	34.0	18.0	27
THED22LH16	16	5/8	M 30x2	11.5	37.5	22.0	32
THED22LH19	19	3/4	M 30x2	14.5	36.5	22.0	32
THED28LH19	19	3/4	M 36x2	14.5	41.0	28.0	41
THED28LH25	25	1	M 36x2	18.5	41.0	28.0	41
THED35LH25	25	1	M 45x2	18.5	48.0	35.0	50
THED35LH31	31	1 1/4	M 45x2	24.5	48.8	35.0	50
THED42LH31	31	1 1/4	M 52x2	24.5	45.5	42.0	55
THED42LH38	38	1 1/2	M 52x2	29.5	46.0	42.0	55

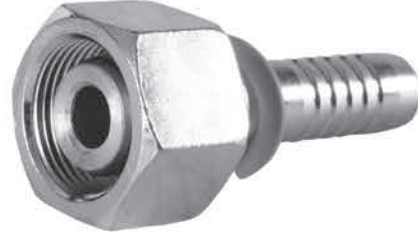
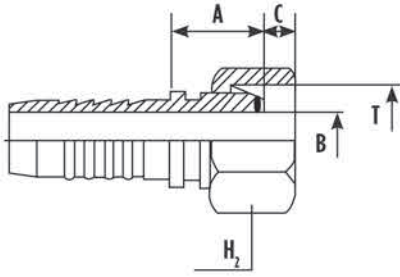

MALZEME KODU Part Ref.	HORTUM İÇ ÇAPI Hose Bore		DİŞ ÖLÇÜSÜ Thread	BOYUT ÖLÇÜLERİ mm Dimensions in mm				
	DN	INCH	T	B	A	C	BORU Ø	H ₂
THDUU06SH6	6	1/4	M 14x1.5	4.0	24.4	3.5	6	17
THDUU08SH6	6	1/4	M 16x1.5	4.0	22.7	3.4	8	19
THDUU10SH6	6	1/4	M 18x1.5	4.0	25.1	3.0	10	22
THDUU12SH6	6	1/4	M 20x1.5	4.0	27.2	2.5	12	24
THDUU06SH8	8	5/16	M 14x1.5	5.0	23.2	2.4	6	17
THDUU08SH8	8	5/16	M 16x1.5	5.0	24.0	2.0	8	19
THDUU10SH8	8	5/16	M 18x1.5	5.0	25.1	3.0	10	22
THDUU12SH8	8	5/16	M 20x1.5	5.0	27.2	2.5	12	24
THDUU08SH10	10	3/8	M 16x1.5	6.5	25.5	2.0	8	22
THDUU10SH10	10	3/8	M 18x1.5	6.5	24.5	2.5	10	22
THDUU12SH10	12	3/8	M 20x1.5	6.5	28.0	2.5	12	24
THDUU16SH10	10	3/8	M 24x1.5	6.5	28.0	2.2	16	30
THDUU12SH12	12	1/2	M 20x1.5	9.0	29.0	2.5	12	24
THDUU16SH12	12	1/2	M 24x1.5	9.0	31.0	3.0	16	30
THDUU20SH12	12	1/2	M 30x2	9.0	30.8	3.5	20	36
THDUU20SH16	16	5/8	M 30x2	11.5	35.5	3.5	20	36
THDUU20SH19	19	3/4	M 30x2	14.5	34.7	2.2	20	36
THDUU25SH19	19	3/4	M 36x2	14.5	37.5	4.5	25	41
THDUU25SH25	25	1	M 36x2	18.5	39.0	4.0	25	41
THDUU30SH25	25	1	M 42x2	18.5	39.9	6.3	30	50
THDUU30SH31	31	1 1/4	M 42x2	24.5	43.0	5.5	30	50
THDUU38SH31	31	1 1/4	M 52x2	24.5	46.5	4.0	38	60
THDUU38SH38	38	1 1/2	M 52x2	29.5	43.0	4.0	38	60

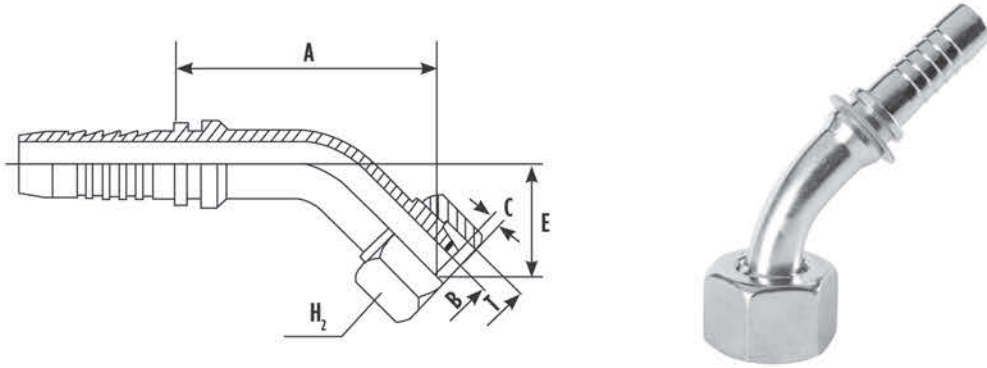

MALZEME KODU Part Ref.	HORTUM İÇ ÇAPI Hose Bore		DIŞ ÖLÇÜSÜ Thread	BOYUT ÖLÇÜLERİ mm Dimensions in mm					
	DN	INCH		T	B	A	C	E	BORU Ø
THKIU06SH6	6	1/4	M 14x1.5	4.0	42.5	3.5	20.0	6	17
THKIU08SH6	6	1/4	M 16x1.5	4.0	43.5	3.4	23.0	8	19
THKIU10SH6	6	1/4	M 18x1.5	4.0	45.5	3.0	22.5	10	22
THKIU12SH6	6	1/4	M 20x1.5	4.0	46.5	2.5	22.0	12	24
THKIU06SH8	8	5/16	M 14x1.5	5.0	44.5	2.4	20.0	6	17
THKIU08SH8	8	5/16	M 16x1.5	5.0	44.5	2.0	23.0	8	19
THKIU10SH8	8	5/16	M 18x1.5	5.0	46.0	3.0	19.5	10	22
THKIU12SH8	8	5/16	M 20x1.5	5.0	47.0	2.5	24.5	12	24
THKIU08SH10	10	3/8	M 16x1.5	6.5	57.0	2.0	23.5	8	22
THKIU10SH10	10	3/8	M 18x1.5	6.5	45.0	2.5	20.0	10	22
THKIU12SH10	12	3/8	M 20x1.5	6.5	45.0	2.5	20.0	12	24
THKIU16SH10	10	3/8	M 24x1.5	6.5	53.0	2.2	27.5	16	30
THKIU12SH12	12	1/2	M 20x1.5	9.0	66.0	2.5	34.0	12	24
THKIU16SH12	12	1/2	M 24x1.5	9.0	60.0	3.0	30.0	16	30
THKIU20SH12	12	1/2	M 30x2	9.0	60.0	3.5	40.0	20	36
THKIU20SH16	16	5/8	M 30x2	11.5	78.0	3.5	29.0	20	36
THKIU20SH19	19	3/4	M 30x2	14.5	87.0	2.2	40.0	20	36
THKIU25SH19	19	3/4	M 36x2	14.5	82.0	4.5	37.5	25	41
THKIU25SH25	25	1	M 36x2	18.5	104.0	4.0	41.5	25	41
THKIU30SH25	25	1	M 42x2	18.5	103.0	6.3	37.5	30	50
THKIU30SH31	31	1 1/4	M 42x2	24.5	121.0	5.5	52.0	30	50
THKIU38SH31	31	1 1/4	M 52x2	24.5	119.5	4.0	53.5	38	60
THKIU38SH38	38	1 1/2	M 52x2	29.5	120.0	4.0	54.0	38	60

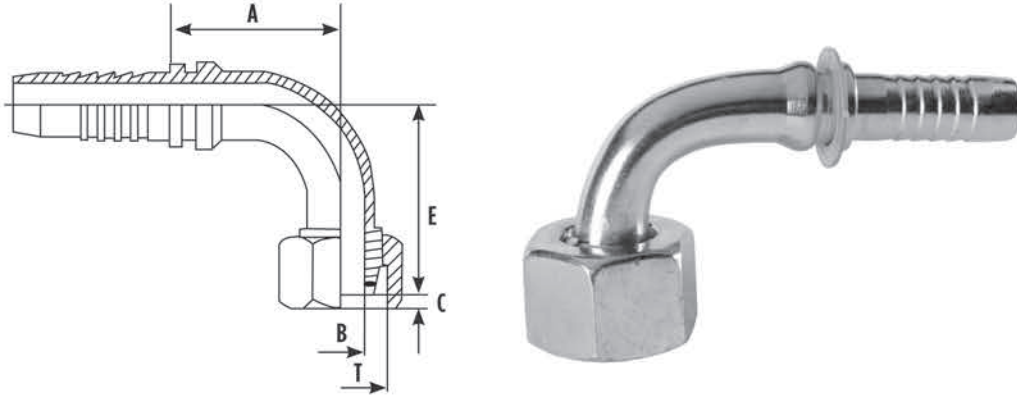

MALZEME KODU Part Ref.	HORTUM İÇ ÇAPI Hose Bore		DİŞ ÖLÇÜSÜ Thread	BOYUT ÖLÇÜLERİ mm Dimensions in mm					
	DN	INCH	T	B	A	C	E	BORU Ø	H ₂
THDOU06SH6	6	1/4	M 14x1.5	4.0	34.0	3.5	32.5	6	17
THDOU08SH6	6	1/4	M 16x1.5	4.0	33.0	3.4	35.0	8	19
THDOU10SH6	6	1/4	M 18x1.5	4.0	33.0	3.0	36.0	10	22
THDOU12SH6	6	1/4	M 20x1.5	4.0	28.0	2.5	40.0	12	24
THDOU06SH8	8	5/16	M 14x1.5	5.0	29.0	2.4	34.5	6	17
THDOU08SH8	8	5/16	M 16x1.5	5.0	32.5	2.0	39.5	8	19
THDOU10SH8	8	5/16	M 18x1.5	5.0	32.0	3.0	40.0	10	22
THDOU12SH8	8	5/16	M 20x1.5	5.0	28.0	2.5	38.0	12	24
THDOU08SH10	10	3/8	M 16x1.5	6.5	37.5	2.0	42.5	8	22
THDOU10SH10	10	3/8	M 18x1.5	6.5	39.0	2.5	33.0	10	22
THDOU12SH10	12	3/8	M 20x1.5	6.5	39.0	2.5	33.0	12	24
THDOU16SH10	10	3/8	M 24x1.5	6.5	36.5	2.2	44.0	16	30
THDOU12SH12	12	1/2	M 20x1.5	9.0	50.0	2.5	38.5	12	24
THDOU16SH12	12	1/2	M 24x1.5	9.0	48.0	3.0	39.0	16	30
THDOU20SH12	12	1/2	M 30x2	9.0	50.0	3.5	52.0	20	36
THDOU20SH16	16	5/8	M 30x2	11.5	53.0	3.5	57.0	20	36
THDOU20SH19	19	3/4	M 30x2	14.5	52.5	2.2	62.0	20	36
THDOU25SH19	19	3/4	M 36x2	14.5	65.0	4.5	68.0	25	41
THDOU25SH25	25	1	M 36x2	18.5	82.0	4.0	71.0	25	41
THDOU30SH25	25	1	M 42x2	18.5	73.0	6.3	77.0	30	50
THDOU30SH31	31	1 1/4	M 42x2	24.5	90.0	5.5	80.0	30	50
THDOU38SH31	31	1 1/4	M 52x2	24.5	87.0	4.0	89.0	38	60
THDOU38SH38	38	1 1/2	M 52x2	29.5	95.0	4.0	99.5	38	60

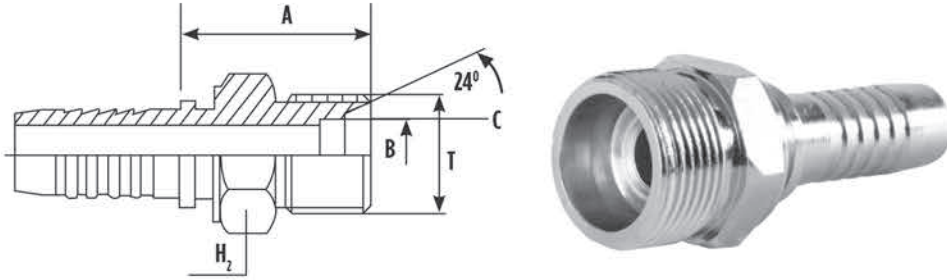

MALZEME KODU Part Ref.	HORTUM İÇ ÇAPı Hose Bore		DİŞ ÖLÇÜSÜ Thread	BOYUT ÖLÇÜLERİ mm Dimensions in mm			
	DN	INCH		T	B	A	C
THED06SH6	6	1/4	M 14x1.5	4.0	23.5	6.0	14
THED08SH6	6	1/4	M 16x1.5	4.0	25.5	8.0	17
THED10SH6	6	1/4	M 18x1.5	4.0	27.0	10.0	19
THED12SH6	6	1/4	M 20x1.5	4.0	27.8	12.0	22
THED06SH8	8	5/16	M 14x1.5	5.0	23.4	6.0	14
THED08SH8	8	5/16	M 16x1.5	5.0	25.0	8.0	17
THED10SH8	8	5/16	M 18x1.5	5.0	27.3	10.0	19
THED12SH8	8	5/16	M 20x1.5	5.0	28.5	12.0	22
THED08SH10	10	3/8	M 16x1.5	6.5	27.0	8.0	17
THED10SH10	10	3/8	M 18x1.5	6.5	28.0	10.0	19
THED12SH10	12	3/8	M 20x1.5	6.5	27.0	12.0	22
THED16SH10	10	3/8	M 24x1.5	6.5	30.0	16.0	24
THED12SH12	12	1/2	M 20x1.5	9.0	28.0	12.0	22
THED16SH12	12	1/2	M 24x1.5	9.0	30.0	16.0	24
THED20SH12	12	1/2	M 30x2	9.0	36.8	20.0	32
THED20SH16	16	5/8	M 30x2	11.5	37.5	20.0	32
THED20SH19	19	3/4	M 30x2	14.5	36.5	20.0	32
THED25SH19	19	3/4	M 36x2	14.5	42.0	25.0	41
THED25SH25	25	1	M 36x2	18.5	41.0	25.0	41
THED30SH25	25	1	M 42x2	18.5	44.5	30.0	46
THED30SH31	31	1 1/4	M 42x2	24.5	43.5	30.0	46
THED38SH31	31	1 1/4	M 52x2	24.5	45.5	38.0	55
THED38SH38	38	1 1/2	M 52x2	29.5	45.5	38.0	55

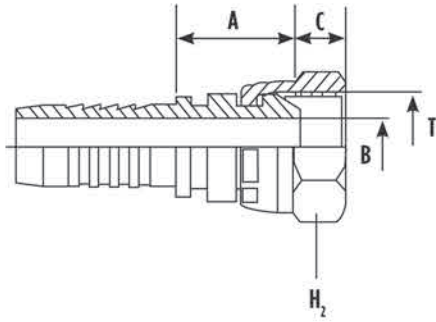

MALZEME KODU Part Ref.	HORTUM İÇ ÇAPI Hose Bore		DİŞ ÖLÇÜSÜ Thread	BOYUT ÖLÇÜLERİ mm Dimensions in mm			
	DN	INCH	T	B	A	C	H ₂
THDUUR10H5	5	3/16	1/8 - 28	3.0	16.0	5.5	14
THDUUR10H6	6	1/4	1/8 - 28	4.0	16.0	5.5	14
THDUUR13H6	6	1/4	1/4 - 19	4.0	21.5	5.0	19
THDUUR17H6	6	1/4	3/8 - 19	4.0	25.5	6.1	22
THDUUR21H6	6	1/4	1/2 - 14	4.0	29.0	4.5	27
THDUUR13H8	8	5/16	1/4 - 19	5.0	20.5	5.0	19
THDUUR17H8	8	5/16	3/8 - 19	5.0	24.5	6.1	22
THDUUR21H8	8	5/16	1/2 - 14	5.0	28.0	4.5	27
THDUUR17H10	10	3/8	3/8 - 19	6.5	25.0	6.1	22
THDUUR21H10	10	3/8	1/2 - 14	6.5	25.5	4.5	27
THDUUR17H12	12	1/2	3/8 - 19	9.0	25.0	6.1	22
THDUUR21H12	12	1/2	1/2 - 14	9.0	23.0	6.5	27
THDUUR23H12	12	1/2	5/8 - 14	9.0	25.0	9.5	27
THDUUR26H12	12	1/2	3/4 - 14	9.0	29.0	7.0	32
THDUUR21H16	16	5/8	1/2 - 14	11.5	28.5	4.5	27
THDUUR23H16	16	5/8	5/8 - 14	11.5	27.0	9.5	27
THDUUR26H16	16	5/8	3/4 - 14	11.5	29.5	7.0	32
THDUUR26H19	19	3/4	3/4 - 14	14.5	30.5	7.0	32
THDUUR33H19	19	3/4	1 - 11	14.5	34.5	10.5	41
THDUUR33H25	25	1	1 - 11	18.5	36.5	10.5	41
THDUUR42H25	25	1	1 1/4 - 11	18.5	38.0	10.5	50
THDUUR42H31	31	1 1/4	1 1/4 - 11	25.0	39.5	10.5	50
THDUUR48H38	38	1 1/2	1 1/2 - 11	29.5	38.5	12.5	55
THDUUR60H51	51	2	2 - 11	41.0	41.0	14.5	70

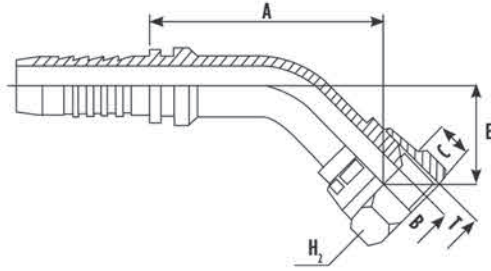

MALZEME KODU Part Ref.	HORTUM ÇAPI Hose Bore		Diş ÖLÇÜSÜ Thread	BOYUT ÖLÇÜLERİ mm Dimensions in mm				
	DN	INCH		T	B	A	C	E
THKIUR10H5	5	3/16	1/8 - 28	3.0	42.0	5.5	14.0	14
THKIUR10H6	6	1/4	1/8 - 28	4.0	46.5	5.5	24.5	14
THKIUR13H6	6	1/4	1/4 - 19	4.0	47.0	5.0	19.0	19
THKIUR17H6	6	1/4	3/8 - 19	4.0	43.5	6.1	20.0	22
THKIUR21H6	6	1/4	1/2 - 14	4.0	55.0	4.5	22.0	27
THKIUR13H8	8	5/16	1/4 - 19	5.0	49.5	5.0	27.0	19
THKIUR17H8	8	5/16	3/8 - 19	5.0	46.0	6.1	18.0	22
THKIUR21H8	8	5/16	1/2 - 14	5.0	53.0	4.5	22.0	27
THKIUR17H10	10	3/8	3/8 - 19	6.5	45.0	6.1	20.0	22
THKIUR21H10	10	3/8	1/2 - 14	6.5	55.0	4.5	18.5	27
THKIUR17H12	12	1/2	3/8 - 19	9.0	64.5	6.1	29.0	22
THKIUR21H12	12	1/2	1/2 - 14	9.0	59.0	6.5	21.5	27
THKIUR23H12	12	1/2	5/8 - 14	9.0	72.0	9.5	25.0	27
THKIUR26H12	12	1/2	3/4 - 14	9.0	69.0	7.0	28.0	32
THKIUR21H16	16	5/8	1/2 - 14	11.5	75.0	4.5	32.0	27
THKIUR23H16	16	5/8	5/8 - 14	11.5	74.0	9.5	26.5	27
THKIUR26H16	16	5/8	3/4 - 14	11.5	83.5	7.0	32.5	32
THKIUR26H19	19	3/4	3/4 - 14	14.5	86.0	7.0	33.5	32
THKIUR33H19	19	3/4	1 - 11	14.5	93.0	10.5	40.5	41
THKIUR33H25	25	1	1 - 11	18.5	104.0	10.5	39.0	41
THKIUR42H25	25	1	1 1/4 - 11	18.5	112.5	10.5	42.0	50
THKIUR42H31	31	1 1/4	1 1/4 - 11	25.0	117.5	10.5	41.5	50
THKIUR48H38	38	1 1/2	1 1/2 - 11	29.5	119.0	12.5	47.5	55
THKIUR60H51	51	2	2 - 11	41.0	175.0	14.5	75.0	70

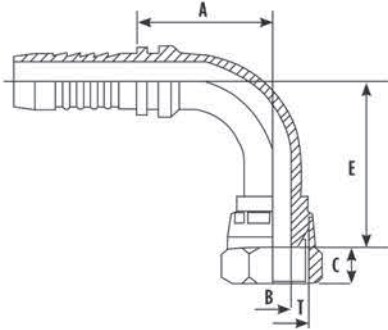

MALZEME KODU Part Ref.	HORTUM ÇAPI Hose Bore		DİŞ ÖLÇÜSÜ Thread	BOYUT ÖLÇÜLERİ mm Dimensions in mm				
	DN	INCH	T	B	A	C	E	H ₂
THDOUR10H5	5	3/16	1/8 - 28	3.0	32.0	5.5	30.0	14
THDOUR10H6	6	1/4	1/8 - 28	4.0	35.5	5.5	32.0	14
THDOUR13H6	6	1/4	1/4 - 19	4.0	34.5	5.0	32.0	19
THDOUR17H6	6	1/4	3/8 - 19	4.0	33.5	6.1	37.0	22
THDOUR21H6	6	1/4	1/2 - 14	4.0	41.5	4.5	39.0	27
THDOUR13H8	8	5/16	1/4 - 19	5.0	34.0	5.0	34.5	19
THDOUR17H8	8	5/16	3/8 - 19	5.0	34.5	6.1	37.0	22
THDOUR21H8	8	5/16	1/2 - 14	5.0	42.0	4.5	39.0	27
THDOUR17H10	10	3/8	3/8 - 19	6.5	37.0	6.1	33.0	22
THDOUR21H10	10	3/8	1/2 - 14	6.5	40.5	4.5	36.5	27
THDOUR17H12	12	1/2	3/8 - 19	9.0	50.0	6.1	43.0	22
THDOUR21H12	12	1/2	1/2 - 14	9.0	42.5	6.5	41.0	27
THDOUR23H12	12	1/2	5/8 - 14	9.0	54.0	9.5	49.5	27
THDOUR26H12	12	1/2	3/4 - 14	9.0	54.0	7.0	51.0	32
THDOUR21H16	16	5/8	1/2 - 14	11.5	48.0	4.5	55.0	27
THDOUR23H16	16	5/8	5/8 - 14	11.5	51.5	9.5	54.5	27
THDOUR26H16	16	5/8	3/4 - 14	11.5	56.0	7.0	58.5	32
THDOUR26H19	19	3/4	3/4 - 14	14.5	61.0	7.0	56.0	32
THDOUR33H19	19	3/4	1 - 11	14.5	61.0	10.5	73.5	41
THDOUR33H25	25	1	1 - 11	18.5	78.5	10.5	75.0	41
THDOUR42H25	25	1	1 1/4 - 11	18.5	73.0	10.5	90.0	50
THDOUR42H31	31	1 1/4	1 1/4 - 11	25.0	95.0	10.5	84.0	50
THDOUR48H38	38	1 1/2	1 1/2 - 11	29.5	103.0	12.5	91.5	55
THDOUR60H51	51	2	2 - 11	41.0	129.0	14.5	124.5	70

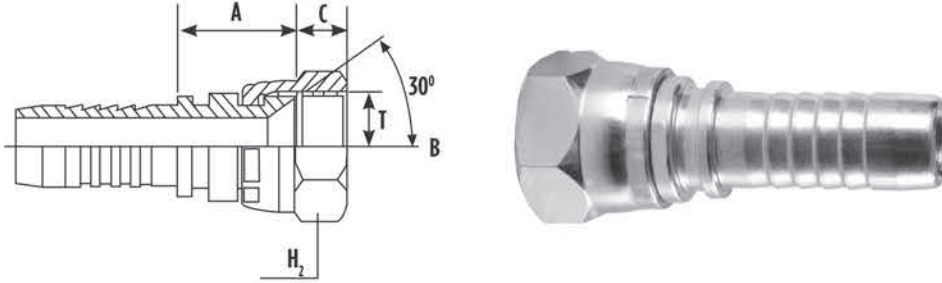

MALZEME KODU Part Ref.	HORTUM İÇ ÇAPI Hose Bore		DİŞ ÖLÇÜSÜ Thread	BOYUT ÖLÇÜLERİ mm Dimensions in mm			
	DN	INCH	T	B	A	C	H ₂
THDUCR13H6	6	1/4	1/4 - 19	4.0	19.5	8.5	17
THDUCR21H6	6	1/4	1/2 - 14	4.0	23	10.5	27
THDUCR21H8	8	5/16	1/2 - 14	5.0	23.5	10.5	27
THDUCR17H10	10	3/8	3/8 - 19	6.5	20.5	9.5	22
THDUCR21H10	10	3/8	1/2 - 14	6.5	23.5	10.5	27
THDUCR21H12	12	1/2	1/2 - 14	9.0	22.5	10.5	27
THDUCR26H16	16	5/8	3/4 - 14	11.5	27.5	13.5	32
THDUCR26H19	19	3/4	3/4 - 14	14.5	26.0	13.5	32
THDUCR33H25	25	1	1 - 11	18.5	33.0	15.0	41
THDUCR42H31	31	1 1/4	1 1/4 - 11	25.0	39.0	15.5	50
THDUCR48H38	38	1 1/2	1 1/2 - 11	29.5	33.0	16.5	55
THDUCR60H51	51	2	2 - 11	41.0	44.0	18.0	70

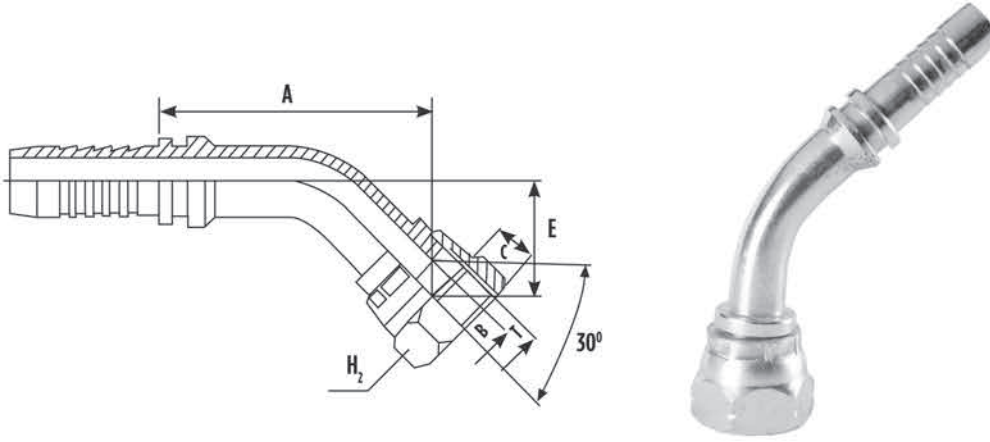

MALZEME KODU Part Ref.	HORTUM ÇAPI Hose Bore		DİŞ ÖLÇÜSÜ Thread	BOYUT ÖLÇÜLERİ mm Dimensions in mm				
	DN	INCH	T	B	A	C	E	H ₂
THKICR13H6	6	1/4	1/4 - 19	4.0	46.5	8.5	19.0	17
THKICR21H6	6	1/4	1/2 - 14	4.0	52.0	10.5	25.0	27
THKICR21H8	8	5/16	1/2 - 14	5.0	54.0	10.5	27.0	27
THKICR17H10	10	3/8	3/8 - 19	6.5	54.0	9.5	23.0	22
THKICR21H10	10	3/8	1/2 - 14	6.5	59.0	10.5	32.0	27
THKICR21H12	12	1/2	1/2 - 14	9.0	66.0	10.5	30.0	27
THKICR26H16	16	5/8	3/4 - 14	11.5	82.0	13.5	34.0	32
THKICR26H19	19	3/4	3/4 - 14	14.5	91.0	13.5	36.0	32
THKICR33H25	25	1	1 - 11	18.5	110.0	15.0	44.0	41
THKICR42H31	31	1 1/4	1 1/4 - 11	25.0	115.0	15.5	39.0	50
THKICR48H38	38	1 1/2	1 1/2 - 11	29.5	125.0	16.5	44.0	55
THKICR60H51	51	2	2 - 11	41.0	175.0	18.0	64.0	70

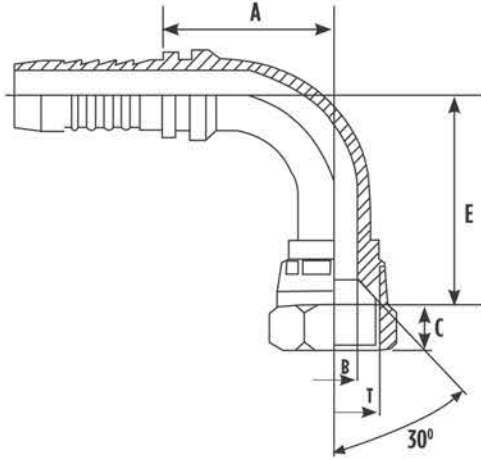

MALZEME KODU Part Ref.	HORTUM ÇAPI Hose Bore		DİŞ ÖLÇÜSÜ Thread	BOYUT ÖLÇÜLERİ mm Dimensions in mm				
	DN	INCH	T	B	A	C	E	H ₂
THDOCR13H6	6	1/4	1/4 - 19	4.0	34.0	8.5	30	17
THDOCR21H6	6	1/4	1/2 - 14	4.0	39.0	10.5	37.5	27
THDOCR21H8	8	5/16	1/2 - 14	5.0	40.0	10.5	35.0	27
THDOCR17H10	10	3/8	3/8 - 19	6.5	41.0	9.5	36.0	22
THDOCR21H10	10	3/8	1/2 - 14	6.5	37.5	10.5	39.0	27
THDOCR21H12	12	1/2	1/2 - 14	9.0	45.5	10.5	42.5	27
THDOCR26H16	16	5/8	3/4 - 14	11.5	65.0	13.5	54.0	32
THDOCR26H19	19	3/4	3/4 - 14	14.5	59.5	13.5	56.0	32
THDOCR33H25	25	1	1 - 11	18.5	84.0	15.0	73.0	41
THDOCR42H31	31	1 1/4	1 1/4 - 11	25.0	85.0	15.5	85.0	50
THDOCR48H38	38	1 1/2	1 1/2 - 11	29.5	103.0	16.5	91.0	55
THDOCR60H51	51	2	2 - 11	41.0	130.0	18.0	130.0	70

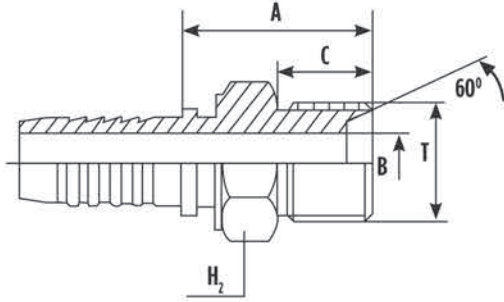

MALZEME KODU Part Ref.	HORTUM İÇ ÇAPI Hose Bore		DİŞ ÖLÇÜSÜ Thread	BOYUT ÖLÇÜLERİ mm Dimensions in mm			
	DN	INCH	T	B	A	C	H ₂
THEDR13H6	6	1/4	1/4 - 19	4.0	25.5	10.0	17
THEDR17H6	6	1/4	3/8 - 19	4.0	28.0	12.0	22
THEDR13H8	8	5/16	1/4 - 19	5.0	25.5	10.0	17
THEDR17H8	8	5/16	3/8 - 19	5.0	28.0	12.0	22
THEDR21H8	8	5/16	1/2 - 14	5.0	34.0	12.0	27
THEDR17H10	10	3/8	3/8 - 19	6.5	28.5	12.0	22
THEDR21H10	10	3/8	1/2 - 14	6.5	32.0	14.5	27
THEDR17H12	12	1/2	3/8 - 19	9.0	27.0	12.0	22
THEDR21H12	12	1/2	1/2 - 14	9.0	33.0	14.5	27
THEDR23H12	12	1/2	5/8 - 14	9.0	32.0	14.5	27
THEDR26H12	12	1/2	3/4 - 14	9.0	32.0	15.5	32
THEDR21H16	16	5/8	1/2 - 14	11.5	32.0	14.5	27
THEDR23H16	16	5/8	5/8 - 14	11.5	32.0	14.5	27
THEDR26H16	16	5/8	3/4 - 14	11.5	37.0	15.5	32
THEDR26H19	19	3/4	3/4 - 14	14.5	37.5	15.5	32
THEDR33H19	19	3/4	1 - 11	14.5	41.5	18.0	41
THEDR33H25	25	1	1 - 11	18.5	42.0	18.0	41
THEDR42H25	25	1	1 1/4 - 11	18.5	44.5	20.5	46
THEDR42H31	31	1 1/4	1 1/4 - 11	25.0	46.0	20.5	46
THEDR48H38	38	1 1/2	1 1/2 - 11	29.5	48.0	21.0	55
THEDR60H51	51	2	2 - 11	41.0	58.0	22.5	65

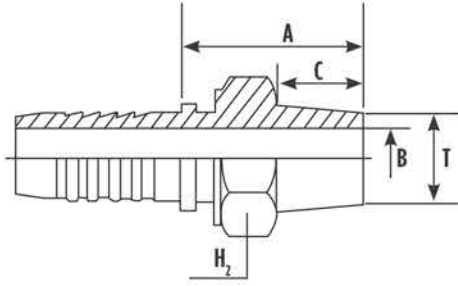

MALZEME KODU Part Ref.	HORTUM ÇAPI Hose Bore		DİŞ ÖLÇÜSÜ Thread	BOYUT ÖLÇÜLERİ mm Dimensions in mm			
	DN	INCH	T	B	A	C	H ₂
THEDN13H6	6	1/4	1/4 - 19	4.0	27.0	14.5	14
THEDN17H6	6	1/4	3/8 - 19	4.0	31.5	16.5	19
THEDN21H8	8	5/16	1/2 - 14	5.0	34.0	18.0	27
THEDN17H10	10	3/8	3/8 - 19	6.5	31.5	16.5	19
THEDN21H10	10	3/8	1/2 - 14	6.5	34.0	18.0	27
THEDN21H12	12	1/2	1/2 - 14	9.0	35.0	18.0	27
THEDN26H12	12	1/2	3/4 - 14	9.0	40.5	21.0	32
THEDN23H16	16	5/8	5/8 - 14	11.5	40.0	20.0	27
THEDN26H16	16	5/8	3/4 - 14	11.5	40.5	21.0	32
THEDN26H19	19	3/4	3/4 - 14	14.5	41.5	21.0	32
THEDN33H25	25	1	1 - 11	18.4	44.0	22.5	36
THEDN42H31	31	1 1/4	1 1/4 - 11	25.0	47.0	24.5	46
THEDN48H38	38	1 1/2	1 1/2 - 11	29.5	48.0	25.0	50
THEDN60H51	51	2	2 - 11	41.0	56.0	32.0	65

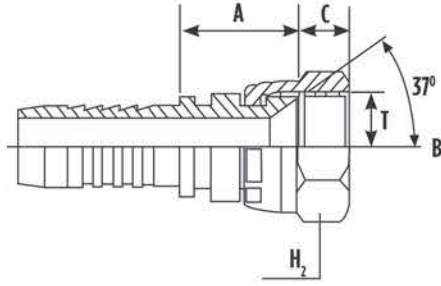

MALZEME KODU Part Ref.	HORTUM İÇ ÇAPI Hose Bore		DİŞ ÖLÇÜSÜ Thread	BOYUT ÖLÇÜLERİ mm Dimensions in mm			
	DN	INCH	T	B	A	C	H ₂
THDUUW11H5	5	3/16	7/16 - 20	3.0	18.0	8.7	14
THDUUW11H6	6	1/4	7/16 - 20	4.0	20.0	8.7	17
THDUUW13H6	6	1/4	1/2 - 20	4.0	18.5	9.5	17
THDUUW14H6	6	1/4	9/16 - 18	4.0	21.0	9.5	19
THDUUW13H8	8	5/16	1/2 - 20	5.0	23.7	9.5	17
THDUUW14H8	8	5/16	9/16 - 18	5.0	21.5	9.5	19
THDUUW16H8	8	5/16	5/8 - 18	5.0	22.5	10.6	22
THDUUW19H8	8	5/16	3/4 - 16	5.0	24.0	10.1	24
THDUUW14H10	10	3/8	9/16 - 18	6.5	20.5	9.5	19
THDUUW16H10	10	3/8	5/8 - 18	6.5	20.0	10.6	22
THDUUW19H10	10	3/8	3/4 - 16	6.5	21.5	10.1	24
THDUUW22H10	10	3/8	7/8 - 14	6.5	22.5	12.7	27
THDUUW19H12	12	1/2	3/4 - 16	9.0	23.0	10.2	24
THDUUW22H12	12	1/2	7/8 - 14	9.0	21.5	12.7	27
THDUUW27H12	12	1/2	1 1/16 - 12	9.0	30.0	14.3	32
THDUUW22H16	16	5/8	7/8 - 14	11.5	22.0	12.7	27
THDUUW27H16	16	5/8	1 1/16 - 12	11.5	27.5	14.3	32
THDUUW27H19	19	3/4	1 1/16 - 12	14.5	26.0	14.3	32
THDUUW33H19	19	3/4	1 5/16 - 12	14.5	31.5	15.1	41
THDUUW27H25	25	1	1 1/16 - 12	18.5	34.0	14.3	32
THDUUW33H25	25	1	1 5/16 - 12	18.5	33.0	15.1	41
THDUUW41H25	25	1	1 5/8 - 12	18.5	38.5	15.9	50
THDUUW41H31	31	1 1/4	1 5/8 - 12	24.5	36.5	15.9	50
THDUUW43H38	38	1 1/2	1 7/8 - 12	29.0	35.5	18.6	55
THDUUW64H51	51	2	2 1/2 - 12	41.0	50.0	23.8	70

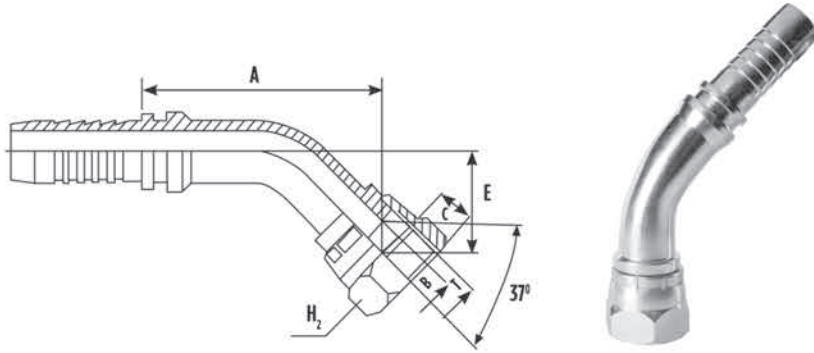

MALZEME KODU Part Ref.	HORTUM İÇ ÇAPI Hose Bore		DİŞ ÖLÇÜSÜ Thread	BOYUT ÖLÇÜLERİ mm Dimensions in mm				
	DN	INCH	T	B	A	C	E	H ₂
THKI UW11H5	5	3/16	7/16 - 20	3.0	45	8.7	18.0	14
THKI UW11H6	6	1/4	7/16 - 20	4.0	49.5	8.7	20.0	17
THKI UW13H6	6	1/4	1/2 - 20	4.0	45.5	9.5	19.0	17
THKI UW14H6	6	1/4	9/16 - 18	4.0	46.0	9.5	22.0	19
THKI UW13H8	8	5/16	1/2 - 20	5.0	45.5	9.5	19.0	17
THKI UW14H8	8	5/16	9/16 - 18	5.0	45.0	9.5	18.5	19
THKI UW16H8	8	5/16	5/8 - 18	5.0	50.5	10.6	23.0	22
THKI UW19H8	8	5/16	3/4 - 16	5.0	50.5	10.1	23.0	24
THKI UW14H10	10	3/8	9/16 - 18	6.5	52.0	9.5	17.0	19
THKI UW16H10	10	3/8	5/8 - 18	6.5	53.0	10.6	20.5	22
THKI UW19H10	10	3/8	3/4 - 16	6.5	52.5	10.1	24.5	24
THKI UW22H10	10	3/8	7/8 - 14	6.5	58.0	12.7	37.0	27
THKI UW19H12	12	1/2	3/4 - 16	9.0	71.0	10.1	20.0	24
THKI UW22H12	12	1/2	7/8 - 14	9.0	71.0	12.7	27.0	27
THKI UW27H12	12	1/2	1 1/16 - 12	9.0	71.0	14.3	31.0	32
THKI UW22H16	16	5/8	7/8 - 14	11.5	74.0	12.7	31.0	27
THKI UW27H16	16	5/8	1 1/16 - 12	11.5	71.0	14.3	30.0	32
THKI UW27H19	19	3/4	1 1/16 - 12	14.5	89.0	14.3	29.0	32
THKI UW33H19	19	3/4	1 5/16 - 12	14.5	92.0	15.1	45.0	41
THKI UW27H25	25	1	1 1/16 - 12	18.5	90.0	14.3	35.0	32
THKI UW33H25	25	1	1 5/16 - 12	18.5	112.0	15.1	43.5	41
THKI UW41H31	31	1 1/4	1 5/8 - 12	24.5	116.0	15.9	50.0	50
THKI UW43H38	38	1 1/2	1 7/8 - 12	29.0	120.0	18.6	45.0	55
THKI UW64H51	51	2	2 1/2 - 12	41.0	195.0	23.8	55.0	70

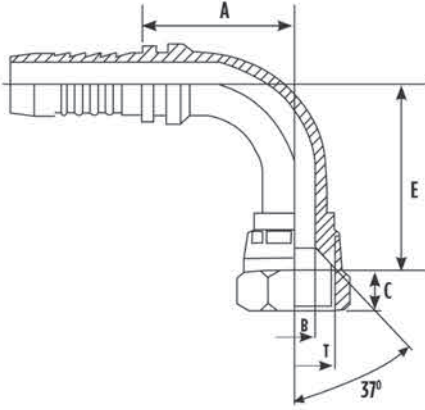

MALZEME KODU Part Ref.	HORTUM İÇ ÇAPI Hose Bore		DIŞ ÖLÇÜSÜ Thread	BOYUT ÖLÇÜLERİ mm Dimensions in mm				
	DN	INCH	T	B	A	C	E	H ₂
THDOUW11H5	5	3/16	7/16 - 20	3.0	34.0	8.7	32	14
THDOUW11H6	6	1/4	7/16 - 20	4.0	37.0	8.7	34.5	17
THDOUW13H6	6	1/4	1/2 - 20	4.0	34.5	9.5	33.0	17
THDOUW14H6	6	1/4	9/16 - 18	4.0	32.0	9.5	36.0	19
THDOUW13H8	8	5/16	1/2 - 20	5.0	34.5	9.5	33.0	17
THDOUW14H8	8	5/16	9/16 - 18	5.0	35.0	9.5	35.0	19
THDOUW16H8	8	5/16	5/8 - 18	5.0	35.0	10.6	38.0	22
THDOUW19H8	8	5/16	3/4 - 16	5.0	33.0	10.1	38.0	24
THDOUW14H10	10	3/8	9/16 - 18	6.5	40.0	9.5	37.0	19
THDOUW16H10	10	3/8	5/8 - 18	6.5	39.0	10.6	38.0	22
THDOUW19H10	10	3/8	3/4 - 16	6.5	40.5	10.1	37.0	24
THDOUW22H10	10	3/8	7/8 - 14	6.5	40.0	12.7	39.0	27
THDOUW19H12	12	1/2	3/4 - 16	9.0	54.0	10.1	44.5	24
THDOUW22H12	12	1/2	7/8 - 14	9.0	50.5	12.7	43.0	27
THDOUW27H12	12	1/2	11/16 - 12	9.0	55.0	14.3	50.0	32
THDOUW22H16	16	5/8	7/8 - 14	11.5	52.0	12.7	52.0	27
THDOUW27H16	16	5/8	11/16 - 12	11.5	60.0	14.3	56.0	32
THDOUW27H19	19	3/4	11/16 - 12	14.5	61.0	14.3	57.5	32
THDOUW33H19	19	3/4	15/16 - 12	14.5	66.5	15.1	68.5	41
THDOUW27H25	25	1	11/16 - 12	18.5	60.0	14.3	55.0	32
THDOUW33H25	25	1	15/16 - 12	18.5	84.0	15.1	72.5	41
THDOUW41H31	31	1 1/4	15/8 - 12	24.5	92.0	15.9	87.0	50
THDOUW43H38	38	1 1/2	17/8 - 12	29.0	99.5	18.6	96.0	55
THDOUW64H51	51	2	2 1/2 - 12	41.0	130.0	23.8	130.0	70

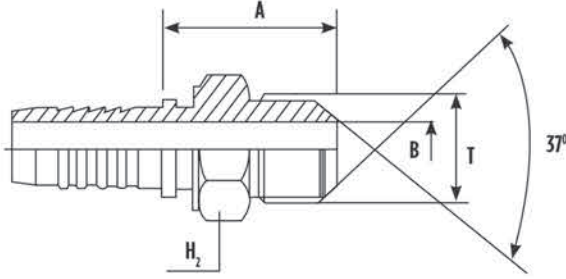

MALZEME KODU Part Ref.	HORTUM İÇ ÇAPI Hose Bore		DİŞ ÖLÇÜSÜ Thread	BOYUT ÖLÇÜLERİ mm Dimensions in mm		
	DN	INCH	T	B	A	H ₂
THEDW11H5	6	1/4	7/16 - 20	4.0	24.2	12
THEDW11H6	6	1/4	1/2 - 20	4.0	28.2	14
THEDW13H6	6	1/4	9/16 - 18	4.0	31.0	17
THEDW14H6	8	5/16	1/2 - 20	5.0	28.0	14
THEDW13H8	8	5/16	9/16 - 18	5.0	29.0	17
THEDW14H8	8	5/16	5/8 - 18	5.0	30.0	17
THEDW16H8	8	5/16	3/4 - 16	5.0	34.5	19
THEDW19H8	10	3/8	9/16 - 18	6.5	31.0	17
THEDW14H10	10	3/8	5/8 - 18	6.5	30.0	17
THEDW16H10	10	3/8	3/4 - 16	6.5	36.0	19
THEDW19H10	10	3/8	7/8 - 14	6.5	35.0	22
THEDW22H10	12	1/2	3/4 - 16	9.0	36.5	19
THEDW19H12	12	1/2	7/8 - 14	9.0	38.5	22
THEDW22H12	12	1/2	11/16 - 12	9.0	43.0	32
THEDW27H12	16	5/8	7/8 - 14	11.5	40.0	24
THEDW22H16	16	5/8	11/16 - 12	11.5	44.0	32
THEDW27H16	19	3/4	11/16 - 12	14.5	46.0	32
THEDW27H19	25	1	11/16 - 12	18.5	47.5	32
THEDW27H25	25	1	15/16 - 12	18.5	48.0	36
THEDW33H25	25	1	15/8 - 12	18.5	54.0	46
THEDW41H31	31	1 1/4	15/8 - 12	24.5	55.0	46
THEDW43H38	38	1 1/2	17/8 - 12	29.0	54.5	50
THEDW64H51	51	2	2 1/2 - 12	41.0	60.0	70

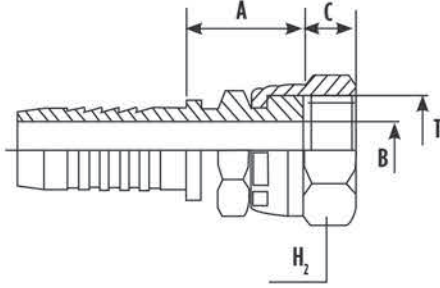

MALZEME KODU Part Ref.	HORTUM İÇ ÇAPI Hose Bore		DİŞ ÖLÇÜSÜ Thread	BOYUT ÖLÇÜLERİ mm Dimensions in mm			
	DN	INCH	T	B	A	C	H ₂
THDUU014H6	6	1/4	9/16 - 18	4.0	29.0	8.0	19
THDUU017H6	6	1/4	11/16 - 16	4.0	29.0	8.0	22
THDUU017H8	8	5/16	11/16 - 16	5.0	29.0	8.0	22
THDUU017H10	10	3/8	11/16 - 16	6.5	28.0	8.0	22
THDUU021H10	10	3/8	13/16 - 16	6.5	35.5	10.5	24
THDUU021H12	12	1/2	13/16 - 16	9.0	36.0	10.5	24
THDUU025H12	12	1/2	1 - 14	9.0	37.0	11.5	30
THDUU025H16	16	5/8	1 - 14	11.5	37.5	11.5	30
THDUU030H16	16	5/8	1 3/16 - 12	11.5	29.0	14.0	36
THDUU030H19	19	3/4	1 3/16 - 12	14.5	33.5	14.0	36
THDUU037H19	19	3/4	1 7/16 - 12	14.5	37.0	12.5	41
THDUU037H25	25	1	1 7/16 - 12	18.5	37.5	12.5	41
THDUU043H25	25	1	1 11/16 - 12	18.5	48.0	12.5	50
THDUU043H31	31	1 1/4	1 11/16 - 12	24.5	47.5	12.5	50

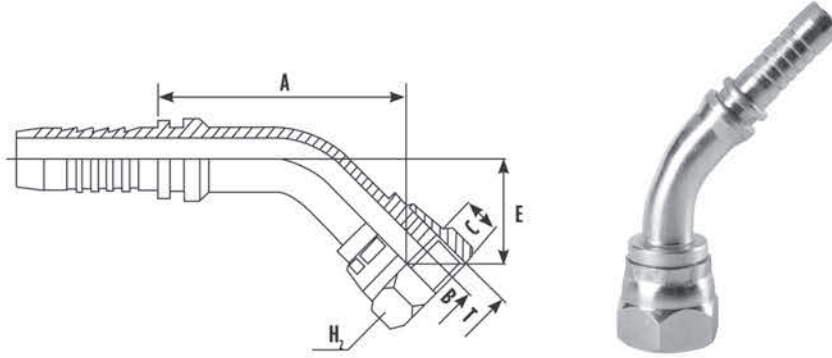

MALZEME KODU Part Ref.	HORTUM ÇAPI Hose Bore		DİŞ ÖLÇÜSÜ Thread	BOYUT ÖLÇÜLERİ mm Dimensions in mm				
	DN	INCH		T	B	A	C	E
THKIU014H6	6	1/4	9/16 - 18	4.0	45.5	8.0	17.0	19
THKIU017H6	6	1/4	11/16 - 16	4.0	46.0	8.0	17.0	22
THKIU017H8	8	5/16	11/16 - 16	5.0	53.0	8.0	21.0	22
THKIU017H10	10	3/8	11/16 - 16	6.5	55.0	8.0	20.0	22
THKIU021H10	10	3/8	13/16 - 16	6.5	57.0	10.5	21.0	24
THKIU021H12	12	1/2	13/16 - 16	9.0	65.0	10.5	25.0	24
THKIU025H12	12	1/2	1 - 14	9.0	65.0	11.5	25.0	30
THKIU025H16	16	5/8	1 - 14	11.5	78.0	11.5	27.0	30
THKIU030H16	16	5/8	1 3/16 - 12	11.5	78.0	14.0	27.0	36
THKIU030H19	19	3/4	1 3/16 - 12	14.5	90.0	13.5	30.0	36
THKIU037H19	19	3/4	1 7/16 - 12	14.5	91.5	12.5	33.0	41
THKIU037H25	25	1	1 7/16 - 12	18.5	111.0	12.5	34.0	41
THKIU043H25	25	1	1 11/16 - 12	18.5	118.0	12.5	50.0	50
THKIU043H31	31	1 1/4	1 11/16 - 12	24.5	122.0	12.5	47.0	50

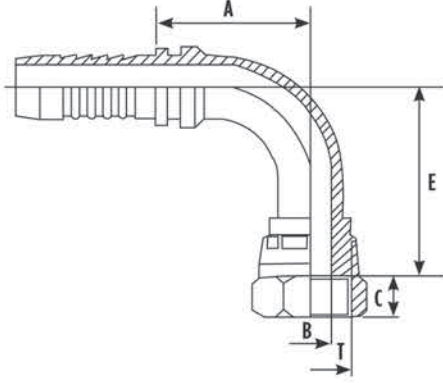

MALZEME KODU Part Ref.	HORTUM ÇAPI Hose Bore		DİŞ ÖLÇÜSÜ Thread	BOYUT ÖLÇÜLERİ mm Dimensions in mm				
	DN	INCH	T	B	A	C	E	H ₂
THDOU014H6	6	1/4	9/16 - 18	4.0	33.0	8.0	28.5	19
THDOU017H6	6	1/4	11/16 - 16	4.0	32.0	8.0	30.0	22
THDOU017H8	8	5/16	11/16 - 16	5.0	38.0	8.0	37.0	22
THDOU017H10	10	3/8	11/16 - 16	6.5	41.0	8.0	37.0	22
THDOU021H10	10	3/8	13/16 - 16	6.5	41.0	10.5	37.0	24
THDOU021H12	12	1/2	13/16 - 16	9.0	51.0	10.5	43.0	24
THDOU025H12	12	1/2	1 - 14	9.0	47.5	11.5	53.0	30
THDOU025H16	16	5/8	1 - 14	11.5	53.0	11.5	59.0	30
THDOU030H16	16	5/8	13/16 - 12	11.5	62.0	14.0	51.0	36
THDOU030H19	19	3/4	13/16 - 12	14.5	61.0	14.0	57.0	36
THDOU037H19	19	3/4	17/16 - 12	14.5	72.5	12.5	61.0	41
THDOU037H25	25	1	17/16 - 12	18.5	82.0	12.5	72.0	41
THDOU043H25	25	1	1 11/16 - 12	18.5	79.0	12.5	80.0	50
THDOU043H31	31	1 1/4	1 11/16 - 12	24.5	84.5	12.5	92.0	50

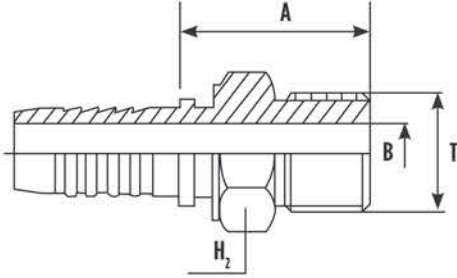

MALZEME KODU Part Ref.	HORTUM ÇAPI Hose Bore		DİŞ ÖLÇÜSÜ Thread	BOYUT ÖLÇÜLERİ mm Dimensions in mm		
	DN	INCH	T	B	A	H ₂
THEDO14H6	6	1/4	9/16 - 18	4.0	26.0	17
THEDO17H6	6	1/4	11/16 - 16	4.0	29.0	19
THEDO17H8	8	5/16	11/16 - 16	5.0	29.0	19
THEDO17H10	10	3/8	11/16 - 16	6.5	27.0	19
THEDO21H10	10	3/8	13/16 - 16	6.5	28.0	22
THEDO21H12	12	1/2	13/16 - 16	9.0	28.0	22
THEDO25H12	12	1/2	1 - 14	9.0	31.0	27
THEDO25H16	16	5/8	1 - 14	11.5	34.0	27
THEDO30H16	16	5/8	1 3/16 - 12	11.5	37.0	32
THEDO30H19	19	3/4	1 3/16 - 12	14.5	40.0	32
THEDO37H19	19	3/4	1 7/16 - 12	14.5	41.0	41
THEDO37H25	25	1	1 7/16 - 12	18.5	41.0	41
THEDO43H25	25	1	1 11/16 - 12	18.5	42.5	46
THEDO43H31	31	1 1/4	1 11/16 - 12	25.0	44.5	46

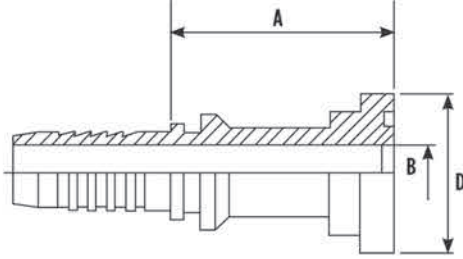

MALZEME KODU Part Ref.	HORTUM ÇAPI Hose Bore		FLANŞLI Flange	BOYUT ÖLÇÜLERİ mm Dimensions in mm		
	DN	INCH		B	A	D
THDUV302H12	12	1/2	1/2	9.0	45.0	30.2
THDUV381H12	12	1/2	2/4	9.0	48.0	38.1
THDUV381H16	16	5/8	3/4	11.5	53.5	38.1
THDUV381H19	19	3/4	3/4	14.5	61.0	38.1
THDUV444H19	19	3/4	1	14.5	65.0	44.4
THDUV381H25	25	1	3/4	18.5	53.0	38.1
THDUV444H25	25	1	1	18.5	68.0	44.4
THDUV508H25	25	1	1 1/4	18.5	70.0	50.8
THDUV603H25	25	1	1 1/2	18.5	72.5	60.3
THDUV444H31	31	1 1/4	1	24.5	68.5	44.4
THDUV508H31	31	1 1/4	1 1/4	24.5	71.0	50.8
THDUV603H31	31	1 1/4	1 1/2	24.5	88.0	60.3
THDUV603H38	38	1 1/2	1 1/2	29.0	84.0	60.3
THDUV714H38	38	1 1/2	2	29.0	84.5	71.4
THDUV714H51	51	2	2	41.0	88.0	71.4
THDUV840H51	51	2	2 1/2	41.0	88.0	84.0

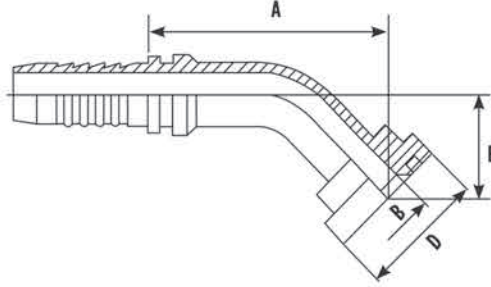

MALZEME KODU Part Ref.	HORTUM ÇAPI Hose Bore		FLANŞLI Flange	BOYUT ÖLÇÜLERİ mm Dimensions in mm			
	DN	INCH		B	A	D	E
THKIV302H12	12	1/2	1/2	9.0	64.0	30.2	26.5
THKIV381H12	12	1/2	3/4	9.0	71.0	38.1	24.5
THKIV381H16	16	5/8	3/4	11.5	81.0	38.1	30.0
THKIV381H19	19	3/4	3/4	14.5	89.5	38.1	32.0
THKIV444H19	19	3/4	1	14.5	89.0	44.4	26.0
THKIV381H25	25	1	3/4	18.5	45.0	38.1	38.0
THKIV444H25	25	1	1	18.5	115.5	44.4	27.5
THKIV508H25	25	1	1 1/4	18.5	110.0	50.8	49.5
THKIV603H25	25	1	1 1/2	18.5	105.0	60.3	48.5
THKIV444H31	31	1 1/4	1	24.5	122.0	44.4	46.0
THKIV508H31	31	1 1/4	1 1/4	24.5	121.0	50.8	48.0
THKIV603H31	31	1 1/4	1 1/2	24.5	130.0	60.3	38.0
THKIV603H38	38	1 1/2	1 1/2	29.0	124.0	60.3	46.0
THKIV714H38	38	1 1/2	2	29.0	124.0	71.4	43.0
THKIV714H51	51	2	2	41.0	115.0	71.4	53.0
THKIV840H51	51	2	2 1/2	41.0	100.0	84.0	53.0

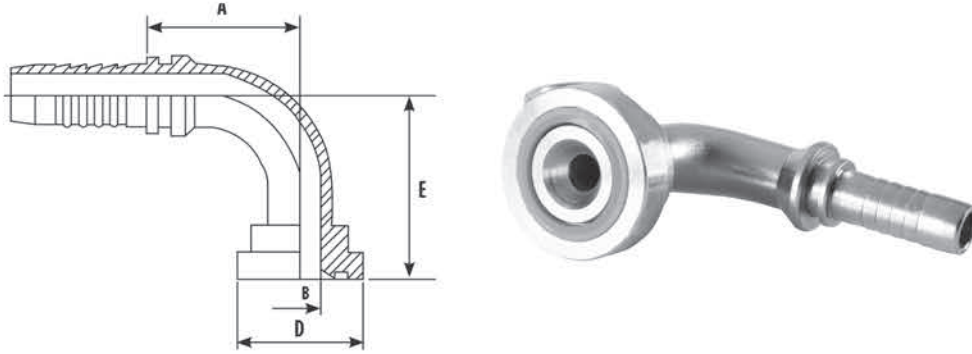

MALZEME KODU Part Ref.	HORTUM ÇAPI Hose Bore		FLANŞLI Flange	BOYUT ÖLÇÜLERİ mm Dimensions in mm			
	DN	INCH		B	A	D	E
THDOV302H12	12	1/2	1/2	9.0	55.5	30.2	49.0
THDOV381H12	12	1/2	3/4	9.0	55.0	38.1	51.0
THDOV381H16	16	5/8	3/4	11.5	60.0	38.1	58.0
THDOV381H19	19	3/4	3/4	14.5	78.0	38.1	62.0
THDOV444H19	19	3/4	1	14.5	74.0	44.4	60.0
THDOV381H25	25	1	3/4	18.5	77.0	38.1	80.0
THDOV444H25	25	1	1	18.5	89.0	44.4	64.0
THDOV508H25	25	1	1 1/4	18.5	90.0	50.8	66.0
THDOV603H25	25	1	1 1/2	18.5	71.0	60.3	79.0
THDOV444H31	31	1 1/4	1	24.5	95.5	44.4	88.0
THDOV508H31	31	1 1/4	1 1/4	24.5	107.0	50.8	72.0
THDOV603H31	31	1 1/4	1 1/2	24.5	99.0	60.3	85.0
THDOV603H38	38	1 1/2	1 1/2	29.0	100.0	60.3	84.0
THDOV714H38	38	1 1/2	2	29.0	103.0	71.4	82.0
THDOV714H51	51	2	2	41.0	137.0	71.4	120.0
THDOV840H51	51	2	2 1/2	41.0	130.0	84.0	120.0

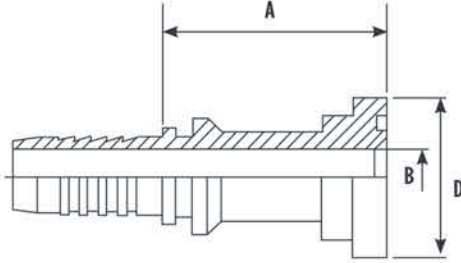

MALZEME KODU Part Ref.	HORTUM ÇAPI Hose Bore		FLANŞLI Flange	BOYUT ÖLÇÜLERİ mm Dimensions in mm		
	DN	INCH		B	A	D
THDUY320H12	12	1/2	1/2	9.0	54.5	32.0
THDUY341H12	12	1/2	5/8	9.0	71.0	34.1
THDUY413H12	12	1/2	3/4	9.0	65.0	41.3
THDUY320H16	16	5/8	1/2	11.5	58.0	32.0
THDUY341H16	16	5/8	5/8	11.5	58.0	34.1
THDUY413H16	16	5/8	3/4	11.5	55.0	41.3
THDUY413H19	19	3/4	3/4	14.5	68.0	41.3
THDUY476H19	19	3/4	1	14.5	64.5	47.6
THDUY413H25	25	1	3/4	18.5	68.0	41.3
THDUY476H25	25	1	1	18.5	70.0	47.6
THDUY540H25	25	1	1 1/4	18.5	81.0	54.0
THDUY476H31	31	1 1/4	1	24.5	78.5	47.6
THDUY540H31	31	1 1/4	1 1/4	24.5	87.0	54.0

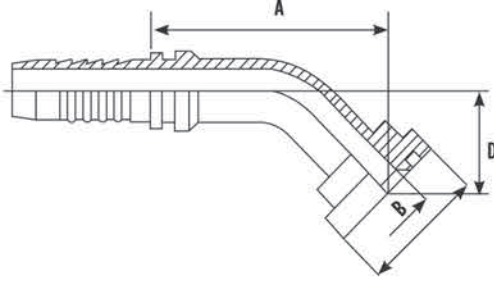

MALZEME KODU Part Ref.	HORTUM ÇAPI Hose Bore		FLANŞLI Flange	BOYUT ÖLÇÜLERİ mm Dimensions in mm			
	DN	INCH		B	A	D	E
MALZEME KODU	12	1/2	1/2	9.0	71.0	32.0	26.0
	12	1/2	5/8	9.0	66.0	34.1	33.0
THKIY320H12	12	1/2	3/4	9.0	67.0	41.3	30.0
THKIY341H12	16	5/8	1/2	11.5	71.0	32.0	36.0
THKIY413H12	16	5/8	5/8	11.5	84.0	34.1	36.0
THKIY320H16	16	5/8	3/4	11.5	82.0	41.3	32.0
THKIY341H16	19	3/4	3/4	14.5	88.0	41.3	30.0
THKIY413H16	19	3/4	1	14.5	88.0	47.6	30.0
THKIY413H19	25	1	3/4	18.5	100.0	41.3	35.0
THKIY476H19	25	1	1	18.5	108.0	47.6	34.0
THKIY413H25	25	1	1 1/4	18.5	100.0	54.0	36.0
THKIY476H25	31	1 1/4	1	24.5	110.0	47.6	42.0
THKIY540H25	31	1 1/4	1 1/4	24.5	120.0	54.0	43.0

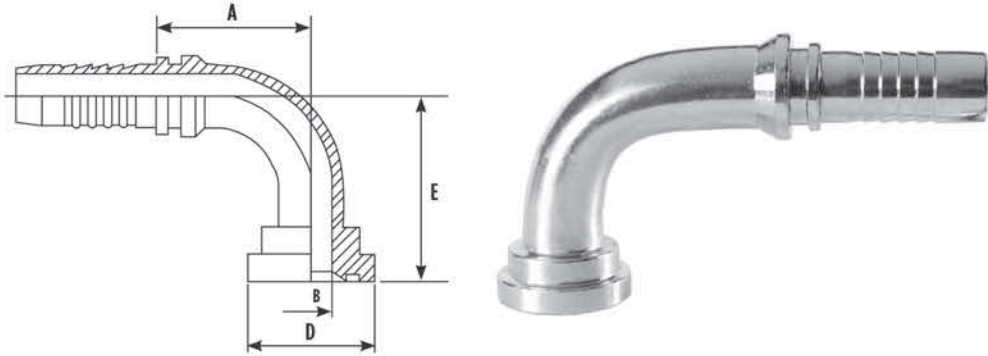

MALZEME KODU Part Ref.	HORTUM ÇAPI Hose Bore		FLANŞLI Flange	BOYUT ÖLÇÜLERİ mm Dimensions in mm			
	DN	INCH		B	A	D	E
THDOY320H12	12	1/2	1/2	9.0	55.0	32.0	48.0
THDOY341H12	12	1/2	5/8	9.0	54.0	34.1	52.0
THDOY413H12	12	1/2	3/4	9.0	49.0	41.3	59.0
THDOY320H16	16	5/8	1/2	11.5	62.5	32.0	56.0
THDOY341H16	16	5/8	5/8	11.5	63.0	34.1	56.0
THDOY413H16	16	5/8	3/4	11.5	60.0	41.3	58.5
THDOY413H19	19	3/4	3/4	14.5	73.0	41.3	64.0
THDOY476H19	19	3/4	1	14.5	70.0	47.6	62.5
THDOY413H25	25	1	3/4	18.5	70.0	41.3	85.0
THDOY476H25	25	1	1	18.5	81.0	47.6	70.0
THDOY540H25	25	1	1 1/4	18.5	85.0	54.0	68.0
THDOY476H31	31	1 1/4	1	24.5	98.0	47.6	81.5
THDOY540H31	31	1 1/4	1 1/4	24.5	100.0	54.0	76.0

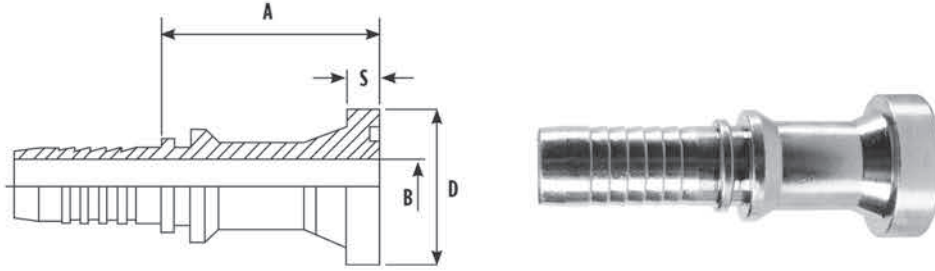

MALZEME KODU Part Ref.	HORTUM ÇAPI Hose Bore		FLANŞLI Flange	BOYUT ÖLÇÜLERİ mm Dimensions in mm			
	DN	INCH		B	A	D	S
THDUZ413H19	19	3/4	3/4	14.5	75.0	41.3	14.2
THDUZ476H19	19	3/4	1	14.5	75.0	47.6	14.2
THDUZ413H25	25	1	3/4	18.5	65.5	41.3	14.2
THDUZ476H25	25	1	1	18.5	69.0	47.6	14.2
THDUZ540H25	25	1	1 1/4	18.5	78.5	54.0	14.2
THDUZ476H31	31	1 1/4	1	24.5	82.0	47.6	14.2
THDUZ540H31	31	1 1/4	1 1/4	24.5	87.5	54.0	14.2
THDUZ635H31	31	1 1/4	1 1/2	24.5	88.5	63.5	14.2
THDUZ635H38	38	1 1/2	1 1/2	29.0	83.5	63.5	14.2
THDUZ800H51	51	2	2	41.0	88.0	80.0	14.2

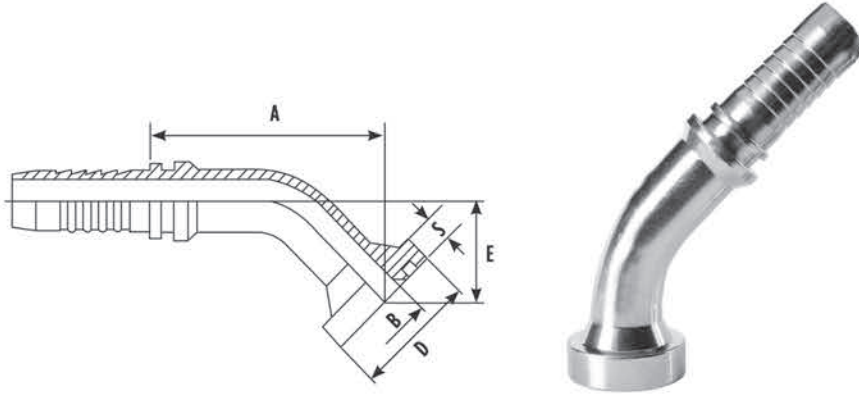

MALZEME KODU Part Ref.	HORTUM ÇAPI Hose Bore		FLANŞLI Flange	BOYUT ÖLÇÜLERİ mm Dimensions in mm				
	DN	INCH		B	A	D	E	S
THKIZ413H19	19	3/4	3/4	14.5	89.0	41.3	34.5	14.2
THKIZ476H19	19	3/4	1	14.5	85.0	47.6	35.0	14.2
THKIZ413H25	25	1	3/4	18.5	98.0	41.3	37.0	14.2
THKIZ476H25	25	1	1	18.5	95.0	47.6	38.0	14.2
THKIZ540H25	25	1	1 1/4	18.5	110.0	54.0	36.0	14.2
THKIZ476H31	31	1 1/4	1	24.5	102.0	47.6	43.0	14.2
THKIZ540H31	31	1 1/4	1 1/4	24.5	120.0	54.0	48.0	14.2
THKIZ635H31	31	1 1/4	1 1/2	24.5	125.0	63.5	40.0	14.2
THKIZ635H38	38	1 1/2	1 1/2	29.0	120.0	63.5	44.0	14.2
THKIZ800H51	51	2	2	41.0	157.0	80.0	53.0	14.2

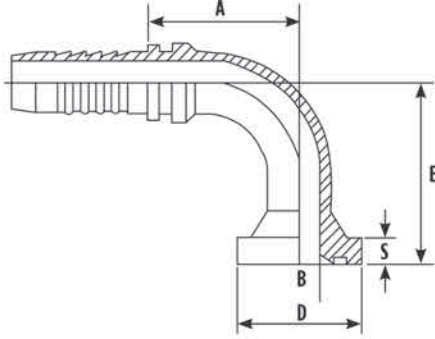

MALZEME KODU Part Ref.	HORTUM ÇAPI Hose Bore		FLANŞLI Flange	BOYUT ÖLÇÜLERİ mm Dimensions in mm				
	DN	INCH		B	A	D	E	S
THDOZ413H19	19	3/4	3/4	14.5	66.0	41.3	65.0	14.2
THDOZ476H19	19	3/4	1	14.5	65.0	47.6	65.0	14.2
THDOZ413H25	25	1	3/4	18.5	77.0	41.3	74.0	14.2
THDOZ476H25	25	1	1	18.5	81.0	47.6	73.0	14.2
THDOZ540H25	25	1	1 1/4	18.5	82.0	54.0	72.0	14.2
THDOZ476H31	31	1 1/4	1	24.5	95.0	47.6	80.0	14.2
THDOZ540H31	31	1 1/4	1 1/4	24.5	97.5	54.0	81.5	14.2
THDOZ635H31	31	1 1/4	1 1/2	24.5	97.5	63.5	77.5	14.2
THDOZ635H38	38	1 1/2	1 1/2	29.0	96.0	63.5	91.0	14.2
THDOZ800H51	51	2	2	41.0	139.0	80.0	115.0	14.2

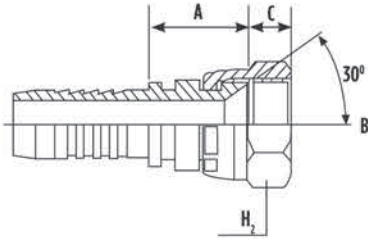

MALZEME KODU Part Ref.	HORTUM İÇ ÇAPI Hose Bore		DİŞ ÖLÇÜSÜ Thread	BOYUT ÖLÇÜLERİ mm Dimensions in mm			
	DN	INCH	T	B	A	C	H ₂
THDUCXM14H6	6	1/4	M 14x1.5	4.0	20.0	9.0	19
THDUCXM16H8	8	5/16	M 16x1.5	5.0	20.0	9.0	22
THDUCXM18H8	8	5/16	M 18x1.5	5.0	19.0	11.0	22
THDUCXM18H10	10	3/8	M 18x1.5	6.5	21.0	10.0	22
THDUCXM22H12	12	1/2	M 22x1.5	9.0	23.0	13.0	27
THDUCXM24H12	12	1/2	M 24x1.5	9.0	24.0	13.0	30
THDUCXM24H16	16	5/8	M 24x1.5	11.0	25.0	13.0	30
THDUCXM30H19	19	3/4	M 30x1.5	14.5	33.0	16.0	36
THDUCXM33H25	25	1	M 33x1.5	18.5	36.0	16.0	41
THDUCXM36H31	31	1 1/4	M 36x1.5	24.5	40.0	19.0	46
THDUCXM42H38	38	1 1/2	M 42x1.5	29.0	41.0	21.0	50

HORTUM ARA EKLERİ - HOSE JOINT

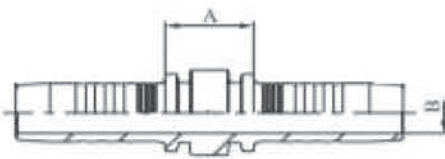

MALZEME KODU	HORTUM İÇ ÇAPI		A	B
	DN	INCH		
THDUAH5	5	3/16"	13	3,2
THDUAH6	6	1/4"	16	4
THDUAH8	8	5/16"	16	5,5
THDUAH10	10	3/8"	17	7
THDUAH12	12	1/2"	22	9
THDUAH16	16	5/8"	28	12
THDUAH19	19	3/4"	30	14
THDUAH25	25	1"	36	19
THDUAH31	31	1"1/4	41,5	25
THDUAH38	38	1"1/2	45	29
THDUAH50	50	2"	42	41



NOTLAR
NOTES



A series of horizontal lines for writing notes, alternating between solid and dashed lines.



A series of horizontal lines for writing notes, alternating between solid and dashed lines.



TAVİLLER

HİDROLİK BORU VE MİL İMALAT SANAYİ A.Ş.

www.taviller.com.tr



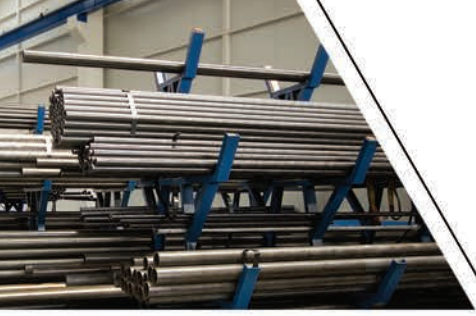

güce
yön veren
teknoloji

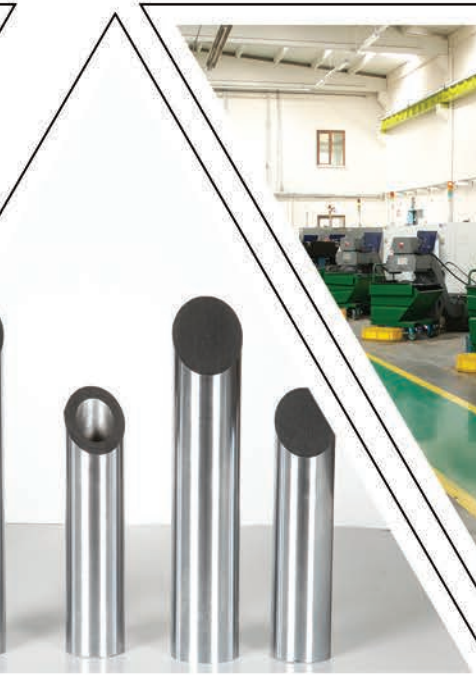

TVL





TAVİLLER

HİDROLİK BORU VE MİL İMALAT SANAYİ A.Ş.

Taviller Hidrolik Mil Boru İmt. San. Tic. A.Ş.

Telefon : +90 256 231 05 10 - PBX

Fax : +90 256 231 05 12 - 13

e-mail : info@taviller.com.tr ; info@hidroliftsan.com.tr ; export@taviller.com.tr

Web Site : www.taviller.com.tr ; www.hidroliftsan.com.tr

Adres : Astim Organize Sanayi Bölgesi Havaalanı Yolu

Üzeri 4.Sokak No:50 Efeler 09100 AYDIN , TÜRKİYE

ŞUBELERİMİZ

İSTANBUL İKİTELLİ

Telefon : +90 212 671 54 46-47 Fax : +90 212 671 54 45 e-mail : ist@taviller.com.tr

Adres : Demirciler Sitesi A1 Blok No:13 İkitelli/İstanbul

İSTANBUL İMES

Telefon : +90 216 420 02 31-32 Fax : +90 216 420 02 34 e-mail : imes@taviller.com.tr

Adres : İmes Sanayi Sitesi C Blok 306 Sokak No:8 Yukarı Dudullu/İstanbul

BURSA KÜÇÜK SANAYİ SİTESİ

Telefon : 0224 443 68 51 Fax : 0224 211 53 41 e-mail : bursa@taviller.com.tr

Adres : Üçevler Mah. Küçük Sanayi Sitesi 24 Sk, No:82-83-84 Blok 45 Nilüfer / Bursa

KONYA İMSAN SANAYİ SİTESİ - 1

Telefon : 0332 345 37 62 Fax : 0332 345 37 65 e-mail : konya@taviller.com.tr

Adres : Fevzi Çakmak Mah. 10756 Sk. No:2/P-R /İmsan Yapı Koop.) Karatay/Konya

KONYA ELİT SANAYİ SİTESİ - 2

Telefon : 0332 345 62 63 Fax : 0332 345 37 65 e-mail : konya@taviller.com.tr

Adres : Fevzi Çakmak Mah. Elit Sanayi Sitesi Sıla Cad. B Blok No:46/P

İZMİR PINARBAŞI

Telefon : 0533 318 97 44 Fax : 0256 231 05 12 e-mail : izmir@taviller.com.tr

Adres : 5.Sanayi Sitesi 7419/12 Sokak No:107 Pınarbaşı İzmir

ANKARA OSTİM

Telefon : +903123859842 Fax : +903123856532 e-mail : ankara@taviller.com.tr

Adres : Ostim Org San Bol. 1233.Sok No:83/85 Yenimahalle Ankara